

CitoPress-1

Instruction Manual



Manual No.: 15777001

Date of Release 10.12.2015
Updated 30.05.2016



CitoPress-1
Instruction Manual

Table of Contents	Page
User's Guide	1
Reference Guide	31
Quick Reference	44

Always state *Serial No* and *Voltage/frequency* if you have technical questions or when ordering spare parts. You will find the *Serial No.* and *Voltage* on the type plate of the machine itself. We may also need the *Date* and *Article No* of the manual. This information is found on the front cover.

The following restrictions should be observed, as violation of the restrictions may cause cancellation of Struers legal obligations:

Instruction Manuals: Struers Instruction Manual may only be used in connection with Struers equipment covered by the Instruction Manual.

Service Manuals: Struers Service Manual may only be used by a trained technician authorised by Struers. The Service Manual may only be used in connection with Struers equipment covered by the Service Manual.

Struers assumes no responsibility for errors in the manual text/illustrations. The information in this manual is subject to changes without notice. The manual may mention accessories or parts not included in the present version of the equipment.

Original instructions. The contents of this manual is the property of Struers. Reproduction of any part of this manual without the written permission of Struers is not allowed.

All rights reserved. © Struers 2016.

Struers
Pederstrupvej 84
DK-2750 Ballerup
Denmark
Telephone +45 44 600 800
Fax +45 44 600 801



CitoPress-1 Safety Precaution Sheet

To be read carefully before use

1. The operator should be fully aware of the use of the machine according to the Instruction Manual.
2. The machine must be placed in a well ventilated room on a working table that is strong enough to support its weight, level and at an appropriate working height.
3. Ensure that the actual voltage corresponds to the voltage stated on the back of the machine and on the heating/cooling unit. The machine must be earthed.
4. Ensure that the water connections are mounted correctly and without leaks. The main water supply should be turned on when the machine is in use. The main water supply should be turned off if you leave the machine unattended.
5. During operation cooling water from the water outlet tube will be **very hot**. Ensure that it is not possible to come into contact with the cooling water.
6. Ensure that the outlet hose is attached to the water outlet system in a safe way.
7. Only use water (or water modified with approved Struers additives) as a cooling medium.
8. After installing a mounting unit:
Ensure that the arrows are aligned to lock the mounting unit into position.
Ensure that the retaining screw is tightened.
Close the cover and replace the top plate.
9. Ensure that the top closure with upper ram is either correctly mounted on the mounting cylinder or completely removed from the mounting cylinder before starting the press.
10. Take care when handling chamfered rams (option) as the metal edges may be sharp.
11. Do not operate the mounting press with a higher force/pressure than recommended for the actual cylinder diameter and resin in Struers Application Guide for Hot Mounting.

CitoPress-1
Instruction Manual

- 12.** Following a heating cycle, ensure the mounting cylinder is cooled for a minimum of two minutes before opening.
- 13.** The machine must be disconnected from the mains prior to any service.
- 14.** Do not operate the machine whilst assembling or disassembling the mounting unit.
- 15.** During operation, always ensure that the top closure is tightly fastened.
- 16.** Do not leave the machine unattended while a mounting process is running.
- 17.** In the event of a hydraulic leak or any other form of failure, the machine must be serviced immediately.

The equipment should only be used for its intended purpose and as detailed in the Instruction Manual.

The equipment is designed for use with consumables supplied by Struers. If subjected to misuse, improper installation, alteration, neglect, accident or improper repair, Struers will accept no responsibility for damage(s) to the user or the equipment.

Dismantling of any part of the equipment, during service or repair, should always be performed by a qualified technician (electromechanical, electronic, mechanical, pneumatic, etc.).



Disposal

Equipment marked with a WEEE symbol  contain electrical and electronic components and must not be disposed of as general waste.

Please contact your local authorities for information on the correct method of disposal in accordance with national legislation.

User's Guide

Table of Contents	Page
1. Getting Started	
Checking the Contents of Packing	3
Unpacking and Placing CitoPress	3
Getting Acquainted with CitoPress	4
Noise Level	5
Supplying Power	6
Opening the Ventilation Valve	7
Supplying Water.....	7
Connecting the Water Inlet	7
Connecting the Water Outlet.....	7
Installing the Lower Ram.....	8
Installing the Mounting Unit	9
Installing the Swivel Arm	12
Mounting the Top Closure	12
Removing the Mounting Unit	13
Removing the Lower Ram.....	14
Changing the Mounting Unit.....	14
Software Settings.....	15
Using Software Menus	16
Configuration Menu.....	17
Setting the Language.....	18
2. Basic Operations	
Using the Controls.....	19
Control Panel of CitoPress-1	19
Control Panel Functions	20
Process Setup Display	21
Using the Process Setup Menu	22
Changing the Process Values	22
Reuse the Process Settings for the Next Sample.....	23
Mounting a Specimen	24
Placing the Specimen	24
Pouring Resin over the Sample.....	24
Installing the Top Closure	24
Starting the Mounting Process	25
Stopping the Mounting Process	26
Removing the Top Closure	26

3. Routine Maintenance

Daily Maintenance.....	27
Removing Residues.....	27
Cleaning the Rams.....	27
Removing the Upper Ram.....	28
Lubricating the Threads of the Top Closure.....	28
Monthly Service.....	29
Cleaning under the Lower Ram.....	29
Yearly Service.....	30
Tighten the Fitted Bolts.....	30
Cleaning the Water Filter.....	30
Decalcifying the Cooling Coil.....	30

1. Getting Started

Checking the Contents of Packing

CitoPress-1

The packing box contains the following items:

- 1 CitoPress-1 machine
- 1 Swivel arm
- 3 Power cables
- 1 Pressure hose
- 1 Filter gasket
- 1 Filter gasket reduction rings
- 1 Gasket
- 2 Gaskets for reduction ring
- 2 Measuring spoons for mounting resin
- 1 Funnel
- 1 Set of instruction manuals

Mounting Unit

- 1 Mounting unit
- 1 Top closure with upper ram
- 1 Lower ram
- 1 Piston pin
- 1 mount release agent, Struers AntiStick
- 1 Scraper

Unpacking and Placing CitoPress

- Remove the coach bolts from all of the transport brackets that secure CitoPress to its transport pallet. Remove the brackets.
- CitoPress should be placed on a sturdy table or work bench at an appropriate working height.
- Place the machine close to connections for mains power, water (inlet) and water (outlet).

Getting Acquainted with CitoPress

Front View

Take a moment to familiarise yourself with the location and names of CitoPress machine's components.

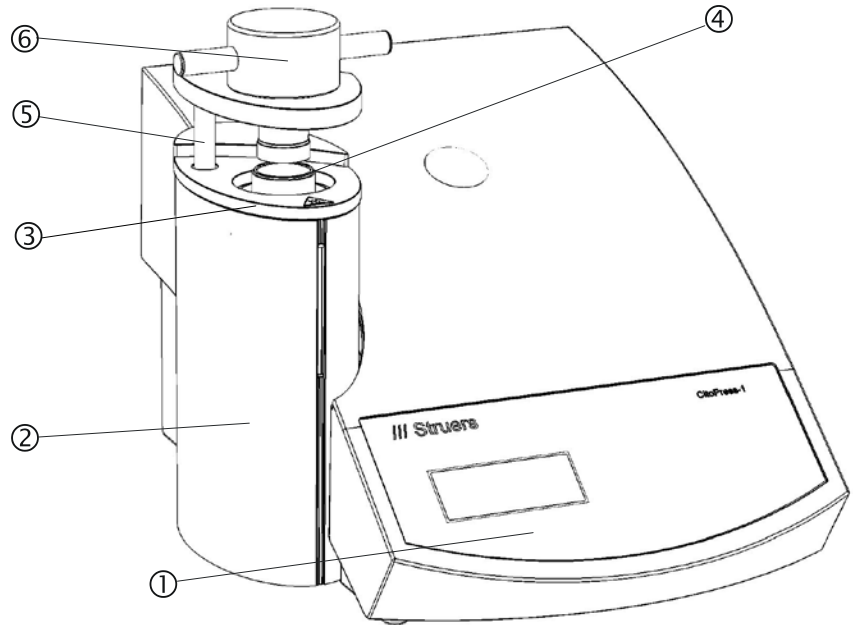

- ① Front Panel
- ② Mounting unit cover
- ③ Mounting unit top plate
- ④ Mounting unit
- ⑤ Swivel arm for top closure
- ⑥ Top closure

Rear View

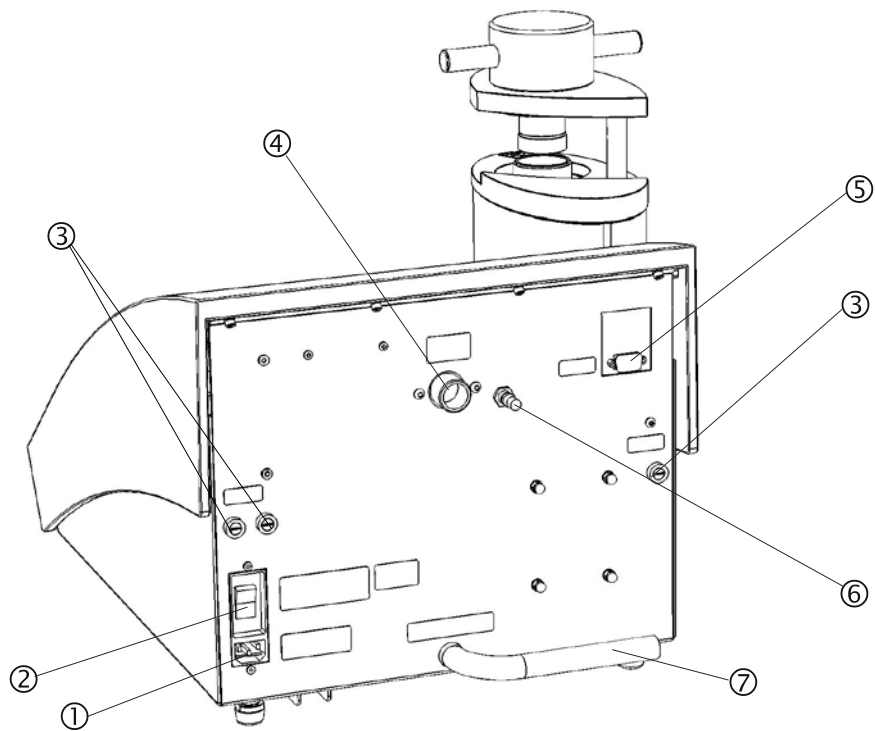

- ① Mains connection socket
- ② Mains switch
- ③ Fuse holders
- ④ Water inlet
- ⑤ RS232 socket
- ⑥ Ventilation valve
- ⑦ Water outlet tube

Noise Level

The noise level of the machine is 63 dB (A) measured when the pump is running, at a distance of 1.0 m/39.4" from the machine.

Supplying Power

Always remember to switch the power off when installing electrical equipment.

Important

Check that the mains voltage corresponds to the voltage stated on the type plate on the machine

CitoPress are shipped with 3 types of Mains cables:

Connection to the Machine



All cables are equipped with an IEC 320 cable connector that has to be connected to the CitoPress.

Single-phase Supply



The 2-pin (European Schuko) plug is for use on single-phase connections.

If the plug supplied on this cable is not approved in your country, then the plug must be replaced with an approved plug. The leads must be connected as follows:

Yellow/green: earth
Brown: line (live)
Blue: neutral



The 3-pin (North American NEMA 5-15P) plug is for use on single-phase connections.

If the plug supplied on this cable is not approved in your country, then the plug must be replaced with an approved plug. The leads must be connected as follows:

Green: earth
Black: line (live)
White: neutral

2-phase Supply



The 3-pin (North American NEMA 6-15P) plug is for use on 2-phase power connections. (This cable is for use with CitoPress-30).

If the plug supplied on this cable is not approved in your country, then the plug must be replaced with an approved plug. The leads must be connected as follows:

Green: earth
Black: line (live)
White: line (live)

WARNING!

DO NOT use the 6-15P cable to connect equipment that use a 110V power supply. Failure to adhere to this may result in material damage.

Opening the Ventilation Valve

To equalise the pressure in the machine's hydraulic system, it is necessary to open the ventilation valve. This valve is closed during transport and is protected by a plastic cap.

- Remove the plastic cap from the valve.
- Fully open the valve
- Secure the valve in the open position using the locking nut.

Supplying Water

Cooling water is provided by the mains water supply. To connect CitoPress water inlet and outlet:

Connecting the Water Inlet



- Mount the pressure hose onto the water inlet tube on the back of CitoPress.
 - Insert the filter gasket in the coupling nut with the flat side against the pressure hose.
 - Tighten the coupling nut completely.
- Mount the other end of the pressure hose on the water mains tap for cold water:
 - Mount the reduction ring with gasket on the water mains tap, if necessary.
 - Tighten the coupling nut completely.

Important

Only connect to cold water

Connecting the Water Outlet

- Place the unconnected end of the water outlet tube in a drain.

Note:

Ensure that the tube is not obstructed and that there is sufficient fall (the drain is lower than CitoPress) so that the cooling water drains away through the tube.

Installing the Lower Ram

- Place the lower ram on the top of the piston rod.

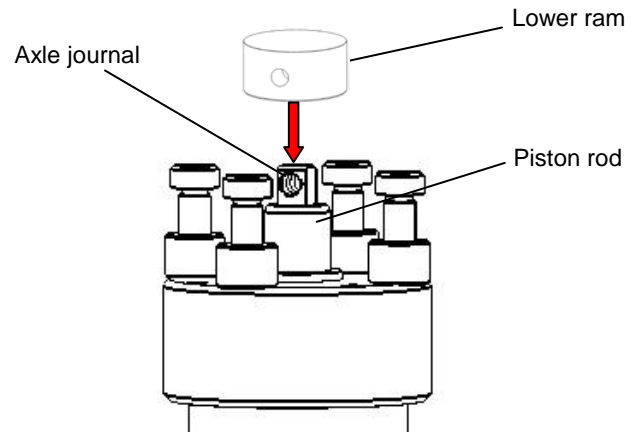

- Turn the lower ram so that the holes in the axle journal on top of the rod and ram line up and insert the piston pin. Make sure that the ends of the pin do not protrude.

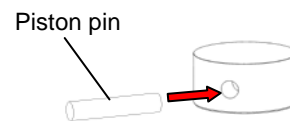

Installing the Mounting Unit

Important:

Do not operate the machine whilst installing the mounting unit.

Connect the water and electrical connections in the order described. Connecting the water connections before the electrical connections could result in water being leaked into the electrical connections and lead to a short.

To install CitoPress's mounting unit:

- Remove the mounting unit's top plate.
- Open the mounting unit's cover.
- Place the mounting unit loosely over the hydraulic cylinder.
- Rotate the mounting unit to line up the keyhole locking slots with the 4 studs on the hydraulic cylinder.

Mounting Unit: Bottom View

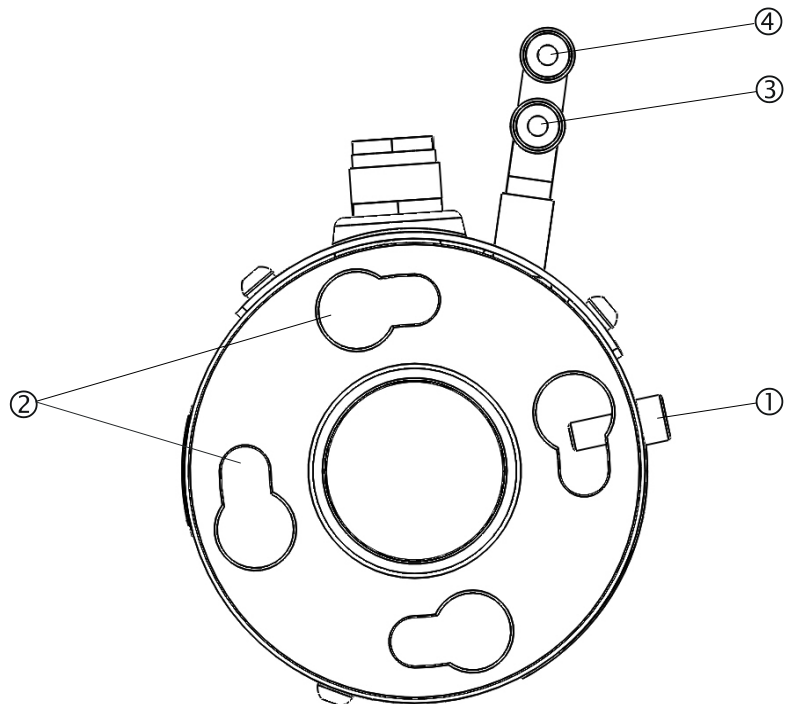

- ① Retaining screw
- ② Keyhole locking slots
- ③ Outlet connection: male fitting (blue)
- ④ Inlet connection: male fitting (red)

CitoPress-1
Instruction Manual

- Lower the unit onto the studs of the hydraulic cylinder.
- Hold the mounting unit's cables and water couplings to one side to ensure that they do not restrict its movement when locking it into position
- When the mounting unit is located on top of the hydraulic cylinder, turn it clockwise until the two arrows are aligned and it locks into position.

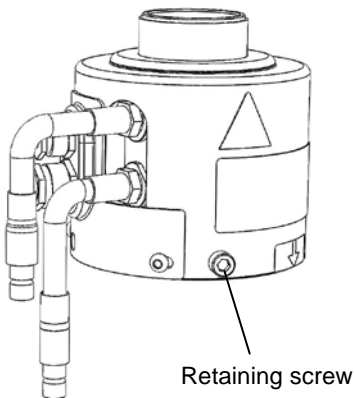
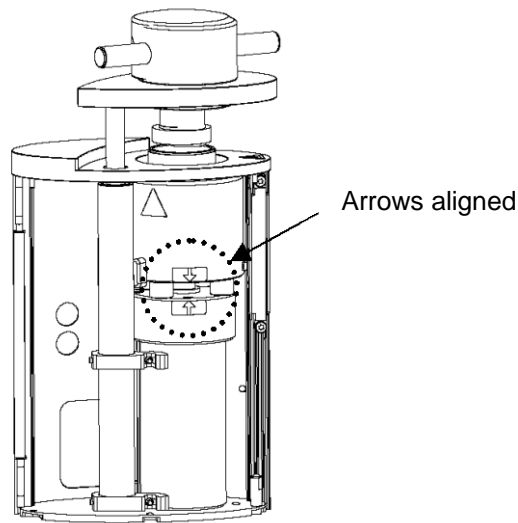

Important:
Double check that the mounting unit is locked into position.
If it is not, CitoPress may be damaged during operation.

- Tighten the retaining screw.
- Connect the mounting unit's two loose cables to the two sockets on CitoPress.
The large plug to the large socket (red dot facing up) and the small plug to the small socket. Tighten the coupling nuts on both plugs to secure the connection.

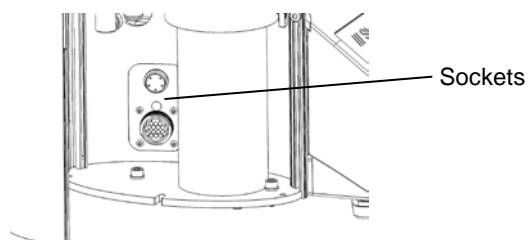

- Connect the male inlet and outlet water couplings on the mounting unit to the female fittings on CitoPress.
 - Hold the spring-loaded collar down and connect the water coupling.
 - Release the spring-loaded collar and check the water connection is secure.

Mounting Unit: Side View

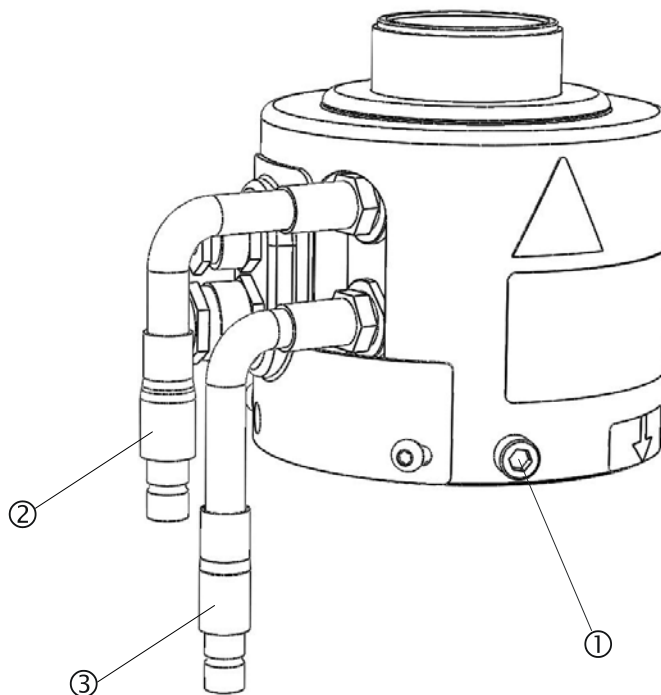

- ① Retaining screw
- ② Inlet connection: male fitting (red)
- ③ Outlet connection: male fitting (blue)

- Close the cover
- Replace the top plate.

Important

To ensure optimal performance and operator safety:

- Ensure that the arrows are aligned to lock the mounting unit into position.
- Ensure that the retaining screw is tightened.
- Close the cover and replace the top plate.

Installing the Swivel Arm

- Mount the swivel arm by sliding it through the hole in the top plate and into the sleeve in the mounting unit cover.

Mounting the Top Closure

- Mount the top closure in the hole in the top of the swivel arm.

Important

After changing the mounting unit, change to the appropriate size of top closure.

Removing the Mounting Unit

Important

Do not operate the machine whilst removing the mounting unit.
Disconnect the machine from the mains electricity and water supplies.

Important

During operation, the mounting unit will be very hot. Before removing the mounting unit, ensure that it is cool enough to be handled.

- Remove the top closure.
- Remove the swivel arm by lifting it out of its mounting.
- Remove the mounting unit's top plate.
- Open the mounting unit's cover.

Important

Disconnect the water and electrical connections in the order described.
Disconnecting the electrical connections before the water connections could result in water being leaked into them.

- Disconnect unit's male inlet and outlet water couplings ("Mounting Unit: Side View", ② and ③) from the machine's female fittings. Wait 5 seconds to allow the water to flow out of the cooling coil.
- Loosen the coupling nuts on both the large and small electrical plugs then pull the plugs out of the sockets.
- Loosen the retaining screw.
- Turn the mounting unit in an anti-clockwise direction until it stops.
- Lift the mounting unit free of the hydraulic cylinder.

Removing the Lower Ram

- Switch CitoPress on.
- Press and hold the RAM DOWN key for a few seconds to lower the ram to its lowest limit.
Switch CitoPress off.

Hint

If it is difficult to access the piston pin:

- Switch CitoPress on.
- Press and hold the RAM UP ▲ key to raise the Mounting Unit clear of the four studs.
- Switch CitoPress off.

- Push the piston pin out of the lower ram.
- Remove the lower ram from the axle journal.

A build-up of resin can make it difficult to removing the lower ram from the mounting unit.
Please contact a Struers Field Service Engineer for advice on how to loosen the lower ram.

Changing the Mounting Unit

- Follow the instructions for "[Removing the Mounting Unit](#)" and "[Installing the Mounting Unit](#)".

Software Settings

When CitoPress is initially powered up, using the mains switch, the following two screens will be displayed:

Initial Start Up Screen

Please Note

The sample screens in this Instruction Manual show a number of possible texts. The actual display screen may differ from the samples in the Manual.



A pop-up will appear to select the preferred Language setting:



Service Information Start Up Screen



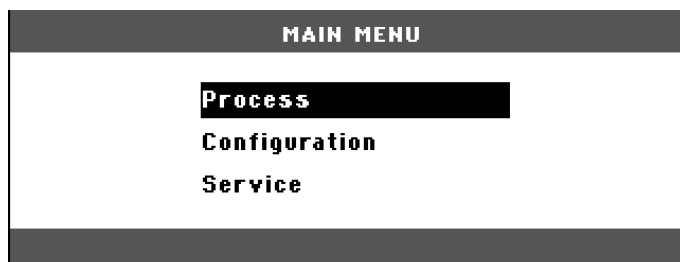

Main Menu

The MAIN MENU will automatically replace these screens.



Using Software Menus

Use the up  and down  menu keys, the escape Esc and enter  keys to navigate and use CitoPress' software menus

Up and Down Menu Keys



- Press the up and down menu keys to highlight menu items.

ESC Key

Esc

- Press the ESC key to return to the previous menu.
- Press the ESC key to exit a selected item, discarding any changes that have been made.

Enter Key



- Press the enter key to select a highlighted item.
- Press the enter key to save a value that has been changed

Configuration Menu

The following is a description of the items found in the CONFIGURATION menu.

CONFIGURATION	
Language	English
Display contrast	25
Temperature unit	°C
Pressure unit	bar
Acoustic signal	ON

Language

The language can be set to English (default), German, French, Spanish or Japanese.

Display contrast

The contrast settings of the display can be adjusted to suit individual preferences (default value: 25, adjustment range: 0-50).

Temperature unit

The temperature display units can be set to be displayed in either Celsius or Fahrenheit.

Pressure unit

The pressure display units can be set to be displayed as Bar or psi.

Acoustic signal

The option to have the machine signal audibly when it has completed the mounting process for a sample can be switched **ON** or **OFF**. If switched on, CitoPress will “beep” when the mounting process has been completed.

In addition, CitoPress will also “beep” when keypads are pressed.

Setting the Language

When the machine is first started the language selected will be English.



To change the language after the initial start up:

← From the MAIN MENU, use  down menu key to highlight the Configuration item. Push the ← enter key to select the item.



← From the CONFIGURATION menu, if necessary, use the menu keys to highlight LANGUAGE.



← Push the enter key.
Use the up  and  down menu keys to highlight the required language then press the ← enter key to select it.



Press Esc key to move from CONFIGURATION menu back to the MAIN MENU.





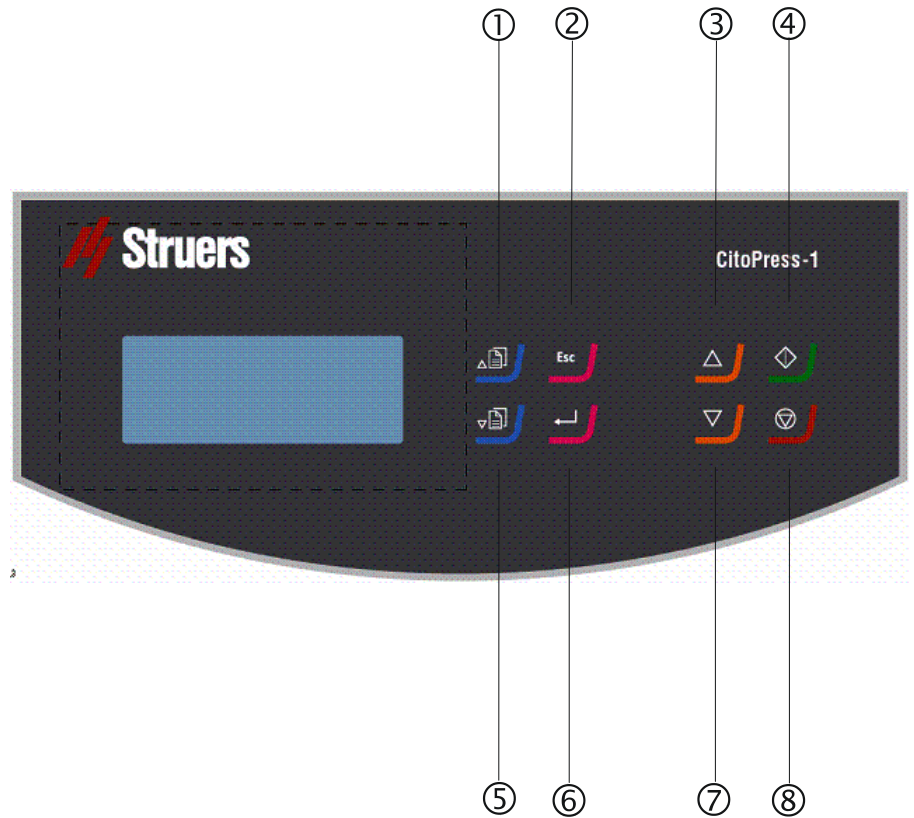

2. Basic Operations

Using the Controls

Control Panel of CitoPress-1



Control Panel Functions

Name	Key	Function	Name	Key	Function
① UP MENU KEY		Moves highlighted menu item upwards and increases values of selected parameters.	⑤ DOWN MENU KEY		Moves highlighted menu item downwards and decreases values of selected parameters.
② ESCAPE	Esc	Moves one step backward in menus and discard modified parameter values if they have not been stored.	⑥ ENTER		Selects highlighted menu items and enters (saves) modified parameter values.
③ RAM UP		Starts the upward movement of the lower ram. The ram automatically stops when its upper limit is reached.	⑦ RAM DOWN		Starts the downward movement of the lower ram. The ram automatically stops when its lower limit is reached
④ START		Starts the machine and recirculation cooling unit, if one is connected.	⑧ STOP		Stops the machine and recirculation cooling unit, if one is connected.

Process Setup Display

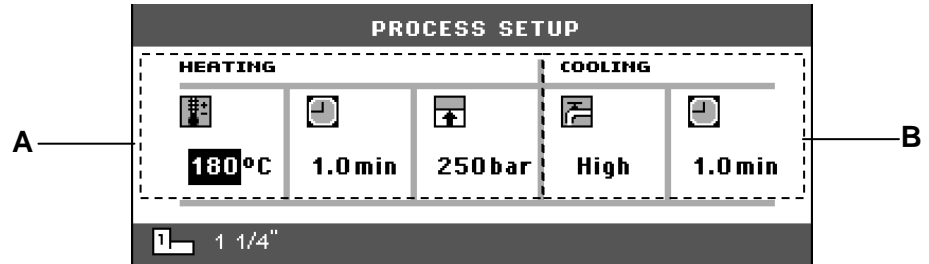

The PROCESS SETUP has two main areas:

- A** HEATING
- B** COOLING





Heating

The HEATING area is used to set up and display the heating values used to process the sample. The values are for:

-  Temperature
-  Duration
-  Pressure

Cooling

The COOLING area is used to set up and display the cooling values used to process the sample. The values are for:



-  Speed: High, Medium or Low
-  Cooling time

Using the Process Setup Menu Changing the Process Values

The process parameter values used by CitoPress for processing samples are set as follows:

Note:

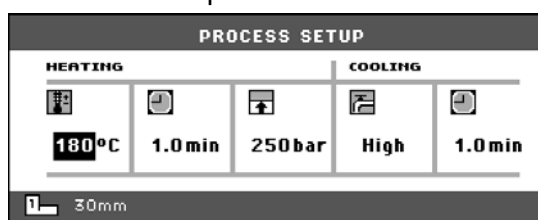

The example below is based on editing the heating temperature value; the procedure for editing other values is the same.

From the PROCESS SETUP menu, use the up  and down  menu keys to highlight the HEATING temperature item.

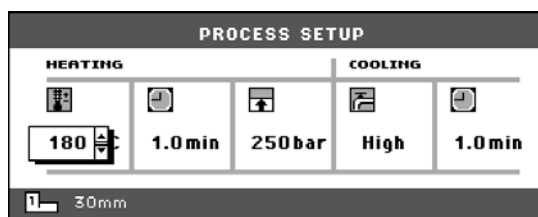

Push the  enter key to select it.



Use the up  and down  menu keys, respectively, to increase or decrease the temperature displayed.

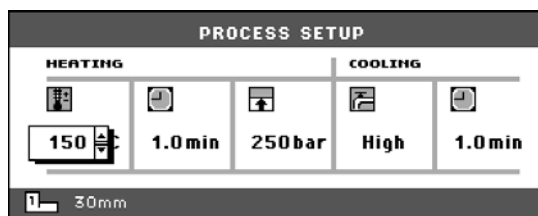

↓ Push the ↵ enter key to store the value.
The display will return to the PROCESS
SETUP menu

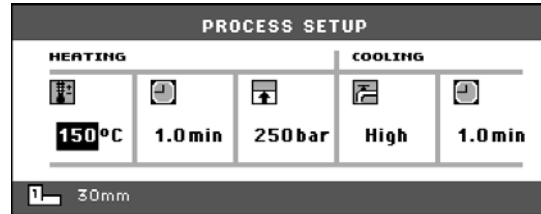

*Reuse the Process Settings for
the Next Sample*

After completing a sample preparation, CitoPress displays the last used process settings (this also applies after switching the press off and on). If these settings are appropriate for the next sample to be processed, prepare the sample then press START \diamond , and the process will run automatically.

Mounting a Specimen

Placing the Specimen

- Press and hold RAM UP ▲ to raise the lower ram to its upper limit.
- Apply mount release agent to the surface of the lower ram.

Important

A thin layer of mount release agent must always be applied to the mounting rams to prevent the resins sticking to the surface. Using Struers' AntiStick a thin layer of stearate powder can easily be dabbed on the rams.

- Place the specimen on the ram. The specimen must be clean, dry and free from grease. The distance between the specimen and the cylinder wall must be minimum 3 mm to avoid cracks in the resin.
- Press RAM DOWN ▼ .
The upper ram will move to its lowest limit.
- Fill a suitable amount of resin into the cylinder using the funnel supplied.

Pouring Resin over the Sample

Important

Always make sure there is sufficient resin to cover the sample after compression. Please note that the volume of the resin reduces when the granulate becomes compressed. If insufficient resin is used, the rams may come in contact with the sample, and the rams and cylinder may be damaged.

Installing the Top Closure

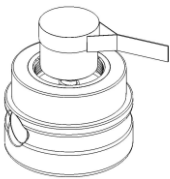

- Before use, remove resin dust from the upper part of the mounting cylinder.
- Clean the cylindrical surface of the upper ram. Cured resin can easily be removed without damage to the surface of the ram using the scraper supplied.
- Apply mount release agent to all accessible surfaces of the upper ram.
- Place the top closure with the upper ram on the mounting cylinder.
- Press the top closure straight down, turning it clockwise until it is tight.

Important

Ensure that the top closure is tightly fastened, before starting the mounting process.

Important

If the ram does not fit easily into the cylinder, then check ram and cylinder for cured resin. The tolerance between the cylinder and the ram is very small and even small amounts of resin from previous mountings may cause problems.

Starting the Mounting Process

WARNING
To prevent damage at installation, ensure that the Mounting Unit is turned clockwise until the two arrows are aligned **BEFORE** starting the mounting process.

- Start the mounting process by pressing START ◊.

Display during the Mounting Process

During mounting the Process Setup display is replaced by the processing display, which illustrates the progress of the current stage (Heating or Cooling) and the time remaining before the mounting process is complete.

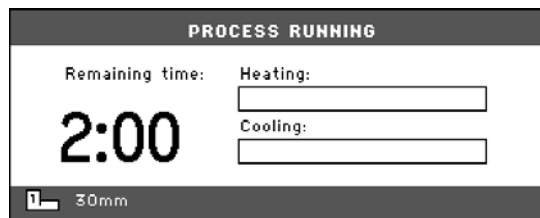

Displaying Process Parameters

↵ To display process parameters, press the ↵ enter key.

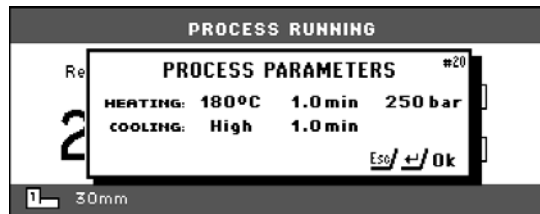

Esc Push the Esc button to return to the process display.

Stopping the Mounting Process

- The machine automatically stops when the cooling time has elapsed. The machine can be stopped at any time during the mounting process by pressing STOP .

Important:

If you have stopped the machine during the mounting process:

Cool the mounting cylinder a minimum 2 min before opening, after a heating period. Please note that the mount may be destroyed.

Removing the Top Closure

When the mounting process is finished:

- Turn the top closure counter-clockwise until released from thread.
- Press RAM UP  to raise the lower ram to its upper limit.
- Turn the top closure to one side to give access to remove the mount.

3. Routine Maintenance

Accumulated resin can restrict movement or cause damage to the rams.

To ensure a longer lifetime for your CitoPress Struers strongly recommends daily cleaning.

Daily Maintenance

Removing Residues

- Clean all accessible surfaces with a moist cloth.
- Open the cover (see, "[Removing the Mounting Unit](#)") and remove residues from exposed surfaces, including the threads.
- Close the cover, see "[Installing the Mounting Unit](#)".

Cleaning the Rams

Before each mounting:

- Check that there is no resin left on the flat surface of the rams from previous operations.
- Clean the cylindrical surface of the upper ram. Cured resin can easily be removed without any damage to the surface of the rams using the scraper supplied.

Important

If the sides of the rams are heavily scratched, they must be replaced. If the top closure has been dropped, causing a dent or deformation in the edge of the upper ram, the ram must also be replaced.

Removing the Upper Ram

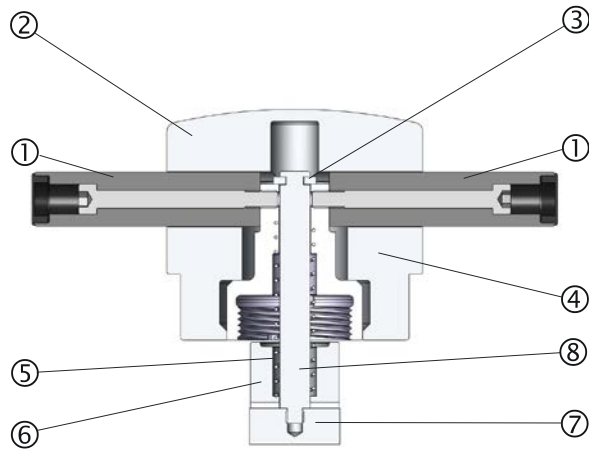

- ① Screws
- ② Top closure cap
- ③ Top nut
- ④ Retaining washer
- ⑤ Spring
- ⑥ Spacer
- ⑦ Upper ram
- ⑧ Rod

- Unscrew the handles on either side of the top closure cap (①).
- Remove the top closure cap (②).
- Remove the retaining washer (④).
- Remove the top nut (③), spring (⑤) and spacer (⑥).
- Pull out the upper ram. Do not remove the rod (⑧) from the upper ram unless absolutely necessary.
- If it is necessary to remove the rod, hold the upper ram (⑦) in a vice or a similar device. The ram surface **must** be protected with plastic or soft metal.

Lubricating the Threads of the Top Closure

A build-up of cured resin may make it difficult to close the top closure.

- Remove any cured resin on the threads of the top closure and mounting unit using the scraper supplied.

Tip

If there is a slight friction in the threads, lubricate using a dry lubricant such as Molybdenum Sulphite or graphite. **DO NOT** lubricate the threads in the joint between the top closure and the mounting cylinder with oil or grease. The mounting cylinder operates at high temperatures, therefore only a dry lubricant, resistant to high temperatures, can be used.

Monthly Service

Cleaning under the Lower Ram

When mounting, some old cured resin will fall down from the lower ram and build up underneath. The cured resin must be cleaned away, to stop it harming the machine.

A pop-up will appear after 200 mounting cycles (default value) to remind the user to clean under the lower ram.

- Press **OK** when the area under the lower ram has been cleaned.
 - Press **Later** to continue operating CitoPress.
-
- Remove the mounting unit.
 - Remove the piston pin and dismount the lower ram.
 - Remove the resin under the lower ram with a cloth or a soft brush.
 - Remount the lower ram and secure with the piston pin.
 - Install the mounting unit.

Yearly Service

Tighten the Fitted Bolts

- Using a 5 mm Allen key, check that the bolts that hold the mounting unit to the cylinder are tight. (The bolts should be tightened with a force of maximum 5 Nm / 4 lbf-ft).

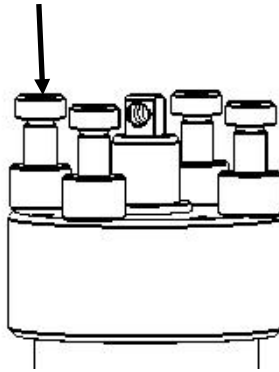

Cleaning the Water Filter

Over time small particles may collect in the water filter and should be removed.

To clean the water filter:

- Switch off the water supply and dismantle the water inlet tube.
- Remove the filter gasket from the coupling nut and rinse thoroughly with water.
- Reconnect the water inlet. (See "[Connecting the Water Inlet](#)").

Decalcifying the Cooling Coil

When using cooling water from the mains tap in areas with a high chalk or mineral content, deposits can build up in the cooling coil. This may reduce the cooling effect, so once a year the cooling coil should be decalcified.

- Remove the mounting unit. (See, "[Removing the Mounting Unit](#)".)
- Drain water from the cooling system.
- Flush the coil with a **mild** decalcifying fluid*, such as that used for coffee machines and leave for ½ hour.
- Flush the cooling coil with clean water.
- Re-install the mounting unit (see, "[Installing the Mounting Unit](#)").

If there are still deposits in the coil, repeat this procedure and leave the decalcifying fluid in the mounting unit overnight before flushing with water the next day.

Decalcifying Fluid *

For decalcification of the mounting unit acetic acid or citric acid is recommended.

Do NOT use oxidising acids such as nitric acid (HNO₃), this will degrade the copper of the mounting unit, and may generate toxic gases.

Do NOT use acids in combination with oxidising agents such as hydrogen peroxide (H₂O₂), this will degrade the copper of the mounting unit.

Reference Guide

Table of Contents	Page
1. Struers Metalog Guide™	32
2. Application Guide for Hot Mounting	33
3. Accessories	33
4. Consumables	33
5. Troubleshooting	34
6. Maintenance	
Service Menus	39
Accessing the Service menus	39
Statistics Menu	40
Sensors Menu	41
7. Technical Data	42

1. Struers Metalog Guide™

Struers Metalog Guide™ offers preparation methods for the most common materials, based on a simple analysis of two key properties: hardness and ductility. Finding the right method, including choice of consumables is easy.

Always consult Struers Metalog Guide™ on the Struers website for the correct preparation method for the actual specimens.

Struers Metalog Guide™

A complete guide to materialographic specimen preparation.
[struers.com/KNOWLEDGE/Metalog Guide](https://www.struers.com/KNOWLEDGE/Metalog%20Guide)

2. Application Guide for Hot Mounting

Useful mounting data and hints can be found in the Struers [Application Guide for Hot Mounting](#) or visit the Struers website on <http://www.struers.com> and see the section on **Knowledge**.

Tip

When using **ClaroFast** in the latest range of Mounting Units (units with a golden casing), increase the Cooling Rate to Medium.

3. Accessories







Please refer to the [CitoPress brochure](#) for details of the range available.

4. Consumables

The use of Struers consumables is recommended. Other products (e.g. coolants) may contain aggressive solvents, which dissolve e.g. rubber seals. The warranty may not cover damaged machine parts (e.g. seals and tubes), where the damage can be directly related to the use of non-Struers consumables.

Please refer to the [Struers Hot Mounting brochure](#) for details of the range available.

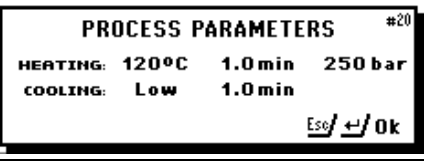
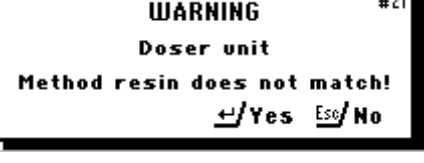
5. Troubleshooting

Display/error	Cause	Action
Error Message		
	Pressure error with the ram movement.	Please contact a Struers Service Technician.
	No digits in the password number being saved.	Press ESC and enter 4 digits for the password number
	Temperature error, mounting unit.	Please contact a Struers Service Technician.
	START has been pressed and no cylinder has been detected.	Check the cylinder is mounted correctly. If error persists, please contact a Struers Service Technician.
	Process Parameters are displayed when ENTER has been pressed whilst a process is running.	To remove the message press ENTER again.
	The Dosing button has been pressed and the resin for the current method does not match the resin name associated with the CitoDoser unit.	To continue, press ENTER. Press ESC to abort the process and mount a dosing unit with the correct resin for the method. Note: The current Doser resin name is displayed by using the "DOSER SETTINGS" menu.
	Error NVram fatal error. It is not possible to load, configure data or methods database.	Please contact a Struers Service Technician.
	There is room for 5 Doser resins in the database.	To save a new Doser resin in the database, delete one of the old Doser resins in the "DOSER SETTINGS" Menu

*CitoPress-1
Instruction Manual*

Display/error	Cause	Action
<div style="border: 2px solid black; padding: 5px; text-align: center;"> ERROR #26 P.O.S.T. Main supply voltage too low! </div>		Turn CitoPress OFF and then turn ON. If this does not help, contact a Struers Service Technician
<div style="border: 2px solid black; padding: 5px; text-align: center;"> ERROR #27 P.O.S.T. Main supply voltage too high! </div>		Turn CitoPress OFF and then turn ON. If this does not help, contact a Struers Service Technician
<div style="border: 2px solid black; padding: 5px; text-align: center;"> ERROR #28 P.O.S.T. PCB voltage out of range! </div>	Voltage overload	Turn CitoPress OFF and then turn ON. If this does not help, contact a Struers Service Technician
<div style="border: 2px solid black; padding: 5px; text-align: center;"> ERROR #29 P.O.S.T. Trafo OVERLOAD! </div>		Turn CitoPress OFF, wait for 5 minutes then turn ON. If this does not help, contact a Struers Service Technician
<div style="border: 2px solid black; padding: 5px; text-align: center;"> ERROR #37 Doser unit not found! ↵/Restart Esc/Cancel </div>	CitoDoser was removed before it is configured.	Replace the CitoDoser and select a resin for the doser.
<div style="border: 2px solid black; padding: 5px; text-align: center;"> WARNING #38 Top closure not tightened! </div>	START has been pressed and the CitoDoser nozzle is positioned over the cylinder.	Remove the CitoDoser nozzle and tighten the top closure.

CitoPress-1
Instruction Manual

Display/error	Cause	Action
Acoustic Signals		
Long beep.	The command can not be accepted.	Please refer to the <i>Basic Operation</i> section in the manual.
Machine Problems		
Process will not start.	Heating time and cooling time are set at zero.	Set the correct times.
Insufficient compression.	Incorrect setting of force/pressure.	Set the correct parameter.
	Defect in the pressure system.	Call a Struers service technician.
Insufficient heating.	Incorrect setting of time or temperature for heating.	Set the correct parameters.
	Defect in the heating system.	Call a Struers service technician.
Insufficient cooling.	Incorrect setting of time for cooling.	Set the correct parameter.
	Mains tap supplying cooling water is either closed or not opened sufficiently.	Open the tap.
	Filter at the water inlet is blocked.	Clean the filter.
	Insufficient water within the Recirculation Cooling Unit. The water is too hot.	Fill to the correct water level. See the section: <i>Routine Maintenance</i>
	Lime scale deposits built up in the cooling coil.	See the section on <i>Decalcifying the Cooling Coil</i> under <i>Routine Maintenance</i> .
	Defect in the cooling system.	Call a Struers service technician.
Cooling water drips underneath the machine.	The quick coupling is not mounted correctly.	Remove the cover from the mounting unit and check the quick coupling connections.

CitoPress-1
Instruction Manual

Display/error	Cause	Action
The top closure will not start threading on the mounting cylinder.	The lower ram has not been lowered sufficiently to make room for the top closure.	Press the Ram down key, to lower the ram.
	The top closure is not mounted correctly.	Press the top closure straight down, turning it counter-clockwise until you hear a click. Turn the top closure clockwise.
	The upper ram is too hot.	Let the top closure and the upper ram cool down. Reduce the mounting temperature.
	Cured resin inside the mounting cylinder.	Clean the mounting cylinder with a brass wire brush.
	Cured resin on the cylindrical surface of the upper ram.	Clean the ram with the scraper supplied.
	The top closure has been dropped on the floor/table, causing a bulge in the edge of the ram.	Replace the upper ram.
	Damage to the threaded connection in the top closure or to the upper ram.	Remove the upper ram from the top closure (see instructions in the section on <i>Routine Maintenance</i>). Try both the following procedures to identify the problem: <ul style="list-style-type: none"> ▪ Try to mount the top closure, without the upper ram. If this is not possible, call a Struers service technician. ▪ Try to insert the disconnected upper ram into the mounting cylinder. If this is not possible, call a Struers service technician.
The top closure cannot be screwed down completely.	Dirt in the threads on the top closure and the mounting cylinder.	Clean the threads. Use only a dry lubricant powder.
	The disc for thermal insulation, placed on the top of the upper ram, has a larger diameter than the upper ram.	Call a Struers service technician.

CitoPress-1
Instruction Manual

Display/error	Cause	Action
The top closure cannot be loosened.	<p>The top closure has not been turned ¼ turn back before starting the process.</p> <p>Cured resin on the cylindrical surface of the top ram.</p> <p>Dirt in the threads of the top closure.</p>	<p>To release the top closure:</p> <ul style="list-style-type: none"> ▪ Move the lower ram up and down several times. <p>If this does not help:</p> <ul style="list-style-type: none"> ▪ Put heating on for 1 min. and try again. <p>If this does not help:</p> <ul style="list-style-type: none"> ▪ Complete a mounting process without force, but with heating and cooling time of about 15 min. <p>If this does not help:</p> <ul style="list-style-type: none"> ▪ Remove the two handles on the top closure. ▪ Remove the plastic cover from the top closure (See the section on Routine Maintenance). ▪ Loosen the top closure with a fork spanner.
The mount has sharp edges which damage SiC papers.		<p>Replace the lower ram with a <i>Chamfered ram</i> (option).</p> 

6. Maintenance

Service Menus

CitoPress is equipped with operator service menus, which provide important information about the operational history and current operational state of the machine.

Accessing the Service menus

From the Main Menu, highlight and then select the Service menu item.

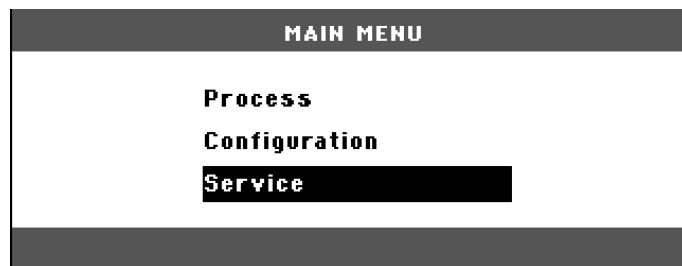

When the Service menu opens, two menu items (Sensors and Statistics) are available.

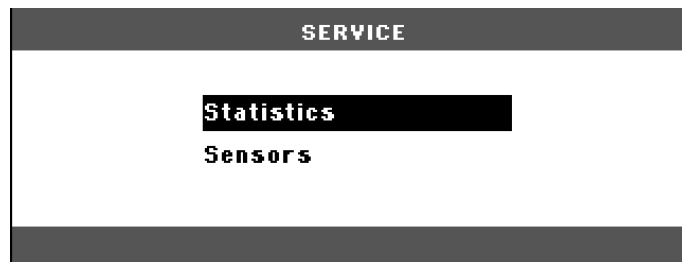

To access these menu items, first highlight and then select them.

Statistics Menu

CitoPress measures and records statistical information about its operation, this data is shown in the Statistics display. The following table provides information about this statistical data.

Item	Display
Statistics	
Serial Number	(number)
Software Version	(number)
Database Version	(number)
Bootloader Version	(number)
TOTAL USAGE	
Total operation time	(hours)
Hydraulic Motor run time	(hours)
Heating Element run time	(hours) /(sum of all units)
Number of ON/OFF operations	(counter)
Number of cooling activations.	(counter)
USAGE SINCE LAST RESET	
Total operation time	(hours)
Operating time since last service	(hours)
Hydraulic Motor run time	(hours)
Heating Element run time	(hours) /(sum of all units)
Number of ON/OFF operations	(counter)
Number of cooling activations	(counter)

Sensors Menu

CitoPress is equipped with a range of sensors. Real time data, provided by these sensors, is shown in the Sensors display. The following table provides information about this sensor data.

Sensor	Display
PCB VOLTAGES	
Main PCB version	ADC + Volt
+DC	ADC + Volt
+24VDC	ADC + Volt
+12VDC	ADC + Volt
+9.8VDC	ADC + Volt
+3.3VDC	ADC + Volt
-22VDC	ADC + Volt
LCD Contrast	ADC + Volt
Transformer overload	Yes/No
PCB OUTPUTS	
Relay for heating unit	OK/short circuited
Valve for cooling unit	OK/short circuited
Relay for voltage selector.	OK/short circuited
RS232 Service	Connected/not connected
Mounting Unit	
Cylinder size	ADC+ (mm or inch)
Cylinder temperature	ADC + (°C)
Cylinder oil pressure	ADC + (bar)
Hydraulic pump current	(ADC + ampere) (mean)
Hydraulic pump voltage	(ADC + +DC volt) (mean)
MAIN SUPPLY VOLTAGE	
Supply voltage at power on.	ADC + Volt
Current supply voltage.	ADC + Volt
Minimum voltage (200 hours).	ADC + Volt (field displaying 200 hours of operation)
Maximum voltage (200 hours).	ADC + Volt (field displaying 200 hours of operation)

7. Technical Data

Subject		Specifications	
		Metric/International	US
Mounting Specifications			
Mounting Units (Optional)	Diameter	25, 30, 40, 50 mm	1¼" 1½"
Compression	Force on piston rod	50–350* bar in steps of 25 bar	725 - 5076* psi in steps of 363 psi
		*) Note: When using 50 mm cylinder diameter, the max force is limited to 250 bar / 3625 psi.	
Heating (with pressure on)	Temperature	120 /150 /180°C	248 /302 /356°F
	Time	Variable between 1 and 15 min	
Cooling (with pressure on)	Time	Variable between 1 and 15 min	
	Rate	High: Full flow (4.8 l/min) Medium: 20% of full flow (0.96 l/min) Low: 3% of full flow (0.14 l/min)	
Physical Specifications			
Water Supply	Tap Water		
	Pressure for tap water	1 - 6 bar	14.5 - 87 psi
	Inlet	Ø ¾"	Ø ¾"
Electrical Supply and consumption	Voltage/frequency	200-240V / 50-60Hz	100-120V / 50-60Hz,
	Power phases	1-phase (N+L1+PE) or 2-phase (L1+L2+PE)	
	Power consumption:		
	Idle Max	8W 1300W @200–240V	8W 1300W @100–120V
	Current	5.6A@200–240V	13A@100–120V
Dimensions and Weight	Width	480 mm	19"
	Depth	560 mm	22"
	Height (Mounting Unit and Top Closure installed)	450 mm	17.7"
	Weight	34 kg	75 lbs

CitoPress-1
Instruction Manual

Subject		Specifications	
		Metric/International	US
Standards Specifications			
Safety Standards		Please refer to the Declaration of Conformity	
Environmental Specifications			
Noise levels	Idle	0 dB (A)	
	Max	63 dB(A)	
Operating Environment	Temperature (operational)	5–40°C	41–104°F
	Humidity (non-condensing)	0–95% RH	
Interface Specifications			
Controls		Touch pad	
LCD display with white LED backlight		160x240 dots	

Quick Reference

Placing the Specimen

- Press and hold RAM UP ▲ to raise the lower ram to its upper limit.
- Apply mount release agent to the surface of the lower ram.
- Place the specimen on the ram.

Pouring Resin Over the Sample

- Press and hold the RAM DOWN ▼ key to lower the ram to its lowest limit.
- Fill a suitable amount of resin into the cylinder through the funnel.

Installing the Top Closure

- Remove resin dust from the upper part of the mounting cylinder.
- Clean the cylindrical surface of the upper ram. Cured resin can easily be removed without damage to the surface of the ram using the scraper supplied.
- Apply mount release agent to all accessible surfaces of the upper ram.
- Place the top closure with the upper ram on the mounting cylinder.
- Press the top closure straight down; turn it clockwise until it is tight.

Starting the Mounting Process

- If necessary, change the appropriate processing parameters.
- Press START ◇.

Stopping the Mounting Process

- The machine automatically stops when the cooling time has elapsed.

Removing the Top Closure

- Turn the top closure counter-clockwise until released from the threads.
- Press RAM UP ▲ to raise the lower ram to its upper limit.
- Turn the top closure to one side to give access to the specimen.

English

Declaration of Conformity



**Manufacturer,
responsible for
Technical File**

Struers A/S
Pederstrupvej 84
DK-2750 Ballerup, Denmark
Telephone +45 44 600 800

Herewith declares that

<i>Product Name:</i>	CitoPress-1/-10/-20 with CitoDoser
<i>Type No:</i>	573/ 574/ 577/ 578/ 579
<i>Machine Type:</i>	Hot Mounting Presses with Resin Doser

is in conformity with the provisions of the following directives:

Safety of Machinery 2006/42/EC according to the following standard(s):
EN ISO 12100:2011, EN ISO 13849-1:2008/AC:2009, EN ISO 13849-2:2014,
EN 60204-1:2006/AC:2010.

EMC-Directive 2004/108/EC according to the following standard(s):
EN 61000-6-2:2005, EN 61000-6-4:2007/A1:2011, EN 61000-3-2:2014, EN 61000-3-3:2013,
EN 61326-1:2013.

RoHS 2011/65/EU according to the following standard(s):
EN 50581:2012.

Supplementary Information The equipment also complies with the following standards:
NFPA70:2014, NFPA79:2012 FCC 47 CFR Part 15, ICES-003

The above has been declared according to the global method, module A

Date: 11.03.2015

Christian Skjold Heyde,
Vice President, R & D and Production, Struers A/S

Dansk

Overensstemmelseserklæring



**Fabrikant,
ansvarlig for Teknisk
Dossier**

Struers A/S
Pederstrupvej 84
DK-2750 Ballerup, Danmark
Telefon 44 600 800

erklærer herved, at

<i>Produktnavn:</i>	CitoPress-1/-10/-20 med CitoDoser
<i>Type nr.:</i>	573+574+577+578+579
<i>Maskintype:</i>	Varmindstøbningspresser med resindoser

er i overensstemmelse med følgende EU-direktiver:

Maskindirektivet 2006/42/EF efter følgende standard(er):
EN ISO 12100:2011, EN ISO 13849-1:2008/AC:2009, EN ISO 13849-2:2014,
EN 60204-1:2006/AC:2010.

EMC-direktivet 2004/108/EF efter følgende standard(er):
EN 61000-6-2:2005, EN 61000-6-4:2007/A1:2011, EN 61000-3-2:2014, EN 61000-3-3:2013,
EN 61326-1:2013.

RoHS 2011/65/EU efter følgende norm(er):
EN 50581:2012.

Supplerende oplysninger Endvidere overholdes følgende standard(er):
NFPA70:2014, NFPA79:2012, FCC 47 CFR Part 15, ICES-003.

Ovenstående overensstemmelse(r) er erklæret iflg. den globale metode, modul A

Dato: 11.03.2015

Christian Skjold Heyde,
Vice President, Udvikling og Produktion, Struers A/S



Pederstrupvej 84
DK-2750 Ballerup
Denmark

CitoPress-1/ -10/ -20



Spare Parts and Diagrams

Manual No.: 15737001

Date of Release FHÉ .20Fí
Á



CitoPress-1/ -10/ -20
Spare Parts and Diagrams

**Always state *Serial No* and *Voltage/frequency*
if you have technical questions or when ordering spare parts.**

The following restrictions should be observed, as violation of the restrictions may cause cancellation of Struers legal obligations:

Instruction Manuals: Struers Instruction Manuals may only be used in connection with Struers equipment covered by the Instruction Manual.

Service Manuals: Struers Service Manuals may only be used by a trained technician authorised by Struers. The Service Manual may only be used in connection with Struers equipment covered by the Service Manual.

Struers assumes no responsibility for errors in the manual text/illustrations. The information in this manual is subject to change without notice. The manual may mention accessories or parts not included in the present version of the equipment.

The contents of this manual are the property of Struers. Reproduction of any part of this manual without the written permission of Struers is not allowed.

All rights reserved. © Struers 20F1 .

Struers A/S
Pederstrupvej 84
DK-2750 Ballerup
Denmark
Telephone +45 44 600 800
Fax +45 44 600 801

Spare Parts and Diagrams

Table of contents

Drawing

CitoPress-1/ -10/ -20

Drawings

CitoPress-20, complete	15740001H
Electronic, assembled	15740065B
Pump unit, assembled.....	15730062B
Hydraulic components f. bottom.....	15730063B
Hydraulic components f. tower.....	15730064A
Left tower, assembled.....	15730020Ü
Right tower, assembled.....	15740022P
Frontplate, assembled.....	15740015H

CitoPress-1

Diagrams

Block Diagram	15773050B
Wiring Diagram	15773100E

CitoPress-10

Diagrams

Block Diagram	15733050B
Wiring Diagram	15733100E

CitoPress-20

Diagrams

Block Diagram	15743050B
Wiring Diagram	15743100E

Some of the drawings may contain position numbers
not used in connection with this manual.

Spare Part list for CitoPress-1/ -10/ -20

Drawing	Pos.		Cat no.
15740001		CitoPress-20, complete	
	220	Seals for towers, 0.66m	15730142
15740065		Electronics, assembled	
	20	Power supply 85-264in. 24V/1A	2PA90025
	130	Trafo 115-230V/36V, 20A, 20%	2MT72324
	150	6.30A T FUSE GLASS 250V, 2 pcs, F1 + F2	2FU14300
	160	15AT FUSE CERAMIC 250V1 pcs F3	2FU17500
15730062		Pump unit, assembled	
	10	Hydr. Pump 36Vdc,1.4liter/min	2YP70108
	20	Male stud connector 1/8" M14	2NH01018
	30	T-swivel w. nut run M14	2NH01014
	40	Swivel conn.w.nut run 1/2" M14	2NH01024
	50	Swivel conn.w.nut run 1/4" M14	2NH01020
15730063		Hydraulic components f. bottom	
	1000	Accumulator ADE 1/2" 0,07L 8bar	2YA00725
	10	Throttle valve ø4	2YI01004
	20	Silencer ø4	2YL10014
	30	Press.trans. 250bar 0.5-4.5V	2HP12250
	40	Quick coupling M10 ø4	2NF11004
	50	Hydraulic hose, 200mm	2NU90891
15730064		Hydraulic components f. tower	
	2000	Male stud connector 1/8" M14	2NH01018
	2010	Hydr.hose 1/8straight 90°elbow	2NU90890
15730020		Left tower, assembled	
	20	Hydraulic cylinder SL81	15730122
	70	Base elevator, assembled	15730035
15740022	160	Right tower, assembled Light panel, 2 pcs (only CitoPress-10/-20)	15740030

Spare Part list for CitoPress-1/ -10/ -20

Drawing
15740015

Pos.		Cat no.
	Frontplate, assembled	
10	Foil, CitoPress-20	15740111
10	Foil, CitoPress-10	15730143
10	Foil, CitoPress-1	15770111
40	Display, 320X240 w. white LED	2HD32024
80	PCB CitoPress, tested	15733001
110	Optical encoder 24p	2HR12411
	Accessories	
	Mains Cable, 0.75mm ² , Schuko	2WC04668
	Mains Cable, AWG16, Nema 5-15P	2WC02520
	Left elevator, assembled	15730040
	Water hose	2NU93020
	Right elevator, assembled	15740040
	Hot Mounting Guide	62020000
	Measuring spoon 20 ml	50300094
	Mains Cable, AWG18, Nema 6-15P	2WC09003

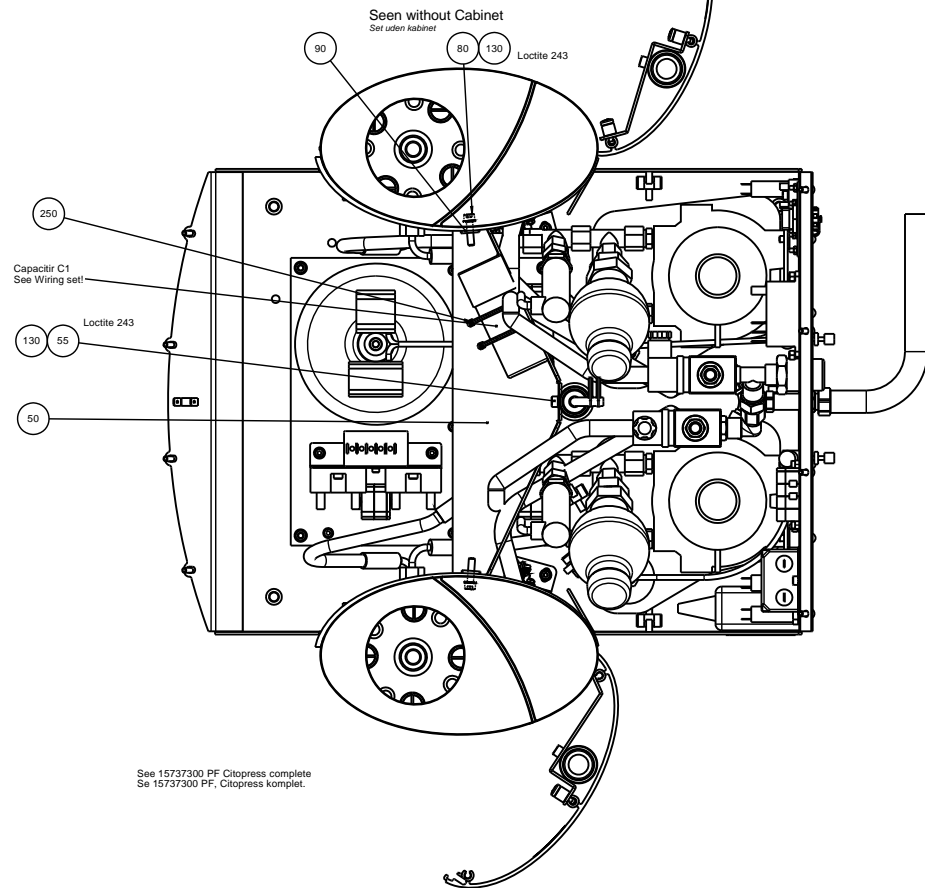
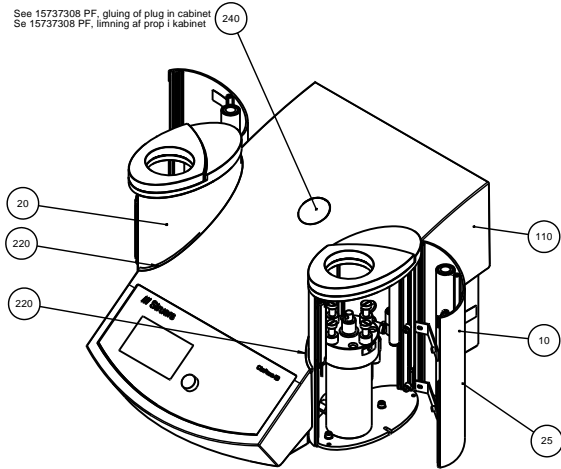
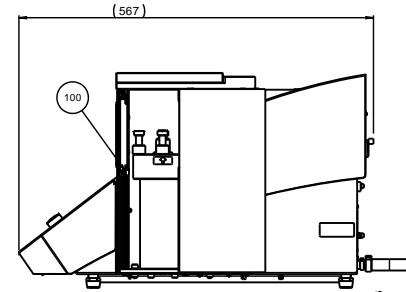
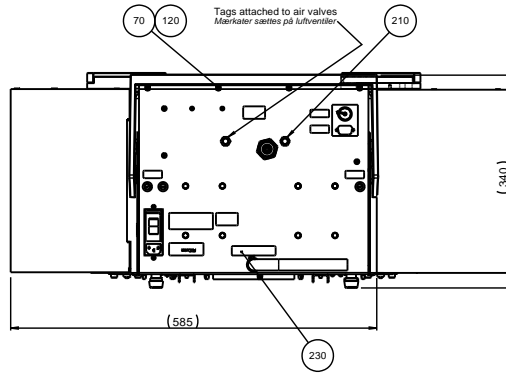
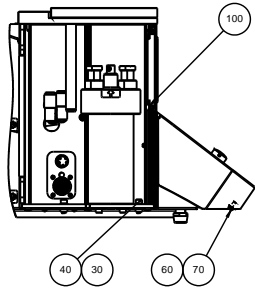

See 15737300 PF Citopress complete
Se 15737300 PF, Citopress komplet.

H	2015-02-02	pos 10 updated	OCR	2012-01-09	CJE / JTV
A	27.02.2006		BMJ		
Revision	Creas. date	Revision description	Draw. Init	Appr. date	Appr. Init
		Material:	Scale: 1:4	Format: A1	Tolerance: DS/ISO 2768 - mK
ID:	Description: 15740001 CitoPress-20, complete				Rev: H

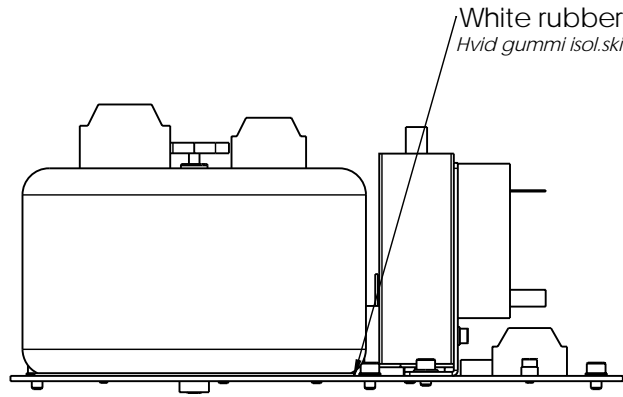

White rubber isolation for trafo (to be delivered with the trafo)
 Hvid gummi isol.skive for trafo (leveres med transformeren)

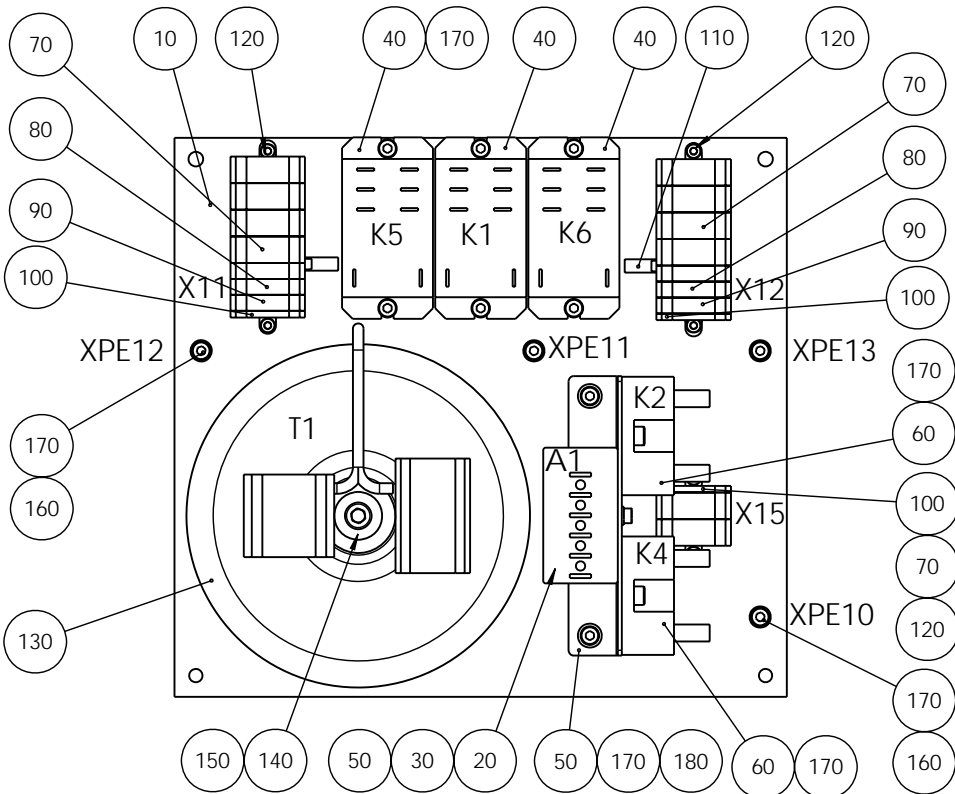
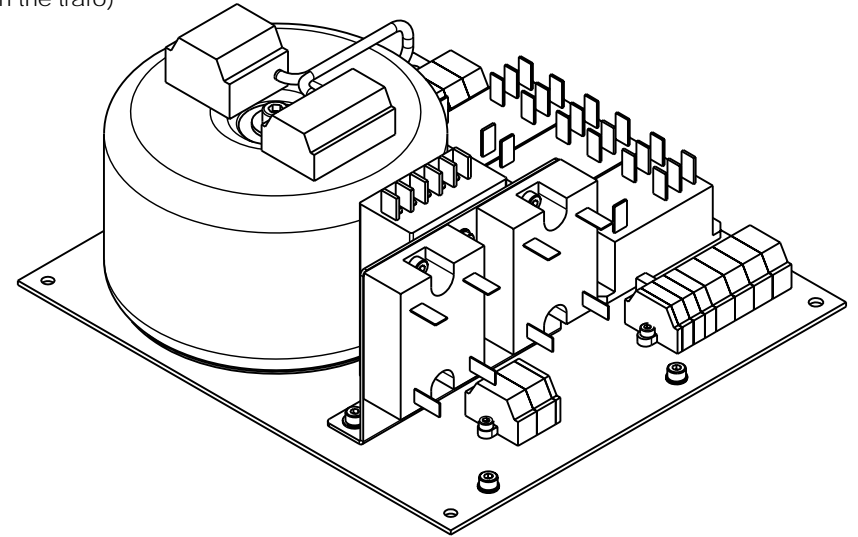



POS. NO.	AMOUNT	DRAW. NO.	MANUFACTURER	TYPE No	NOTE
10	1	15730136 Plate for electronics			
20	1	2PA90025 Power supply 85-264in. 24V_1A	Meanwell	RS25-24	
30	2	2TR50304 MC Skrue M3x4			
40	3	2KL46682 Relay 20A 2sk 24VDC fast on	Finder	Serie 66 66.82	
50	1	15730208 Bracket for power supply			
60	2	2KL82420 Solid state relay 20A AC 12VDC	Celduc	SCF-42324L	
70	10	2XL01331 Terminal block,4-conductor	Wago	261-331	
80	4	2XL01301 Terminal block,2-conductor	Wago	261-301	
90	2	2XL01307 Terminal block 2-cond. yegn	Wago	261-307	
100	3	2XL11361 End plate w.fixing fl. 261-361	Wago	261-361	
110	2	2XL31402 JUMPER BAR, 2-WAY COMB-TYPE	Wago	261-402	
120	6	2TR50306 MC Skrue M3x6 A2			
130	1	2MT72324 Trafo 115-230V-36V 20A 20%	Ulveco	AA-72324	
140	1	2ZA20006 Skive 6 DIN 9021 A2			
150	1	2TR50680 MC skrue M6x80 A2			
160	8	2ZI40405 SKIVE M.UDV. FORTANDING 4 A4			
170	16	2TR50406 MC skrue M4x6 A2			
180	2	2ZA10004 Skive 4 DIN 125 A A2			
190	2	2ZA10003 Skive 3 DIN 125 A A2			

Revision	Crea. date	Revision description	Draw. Init	Appr. date	Appr. Init
C					
B	27-09-06	Pos 170-190 added, amount of pos 40 changed	JLI	27-09-06	JLI
A	05-05-06		BMJ	05-05-06	JLI

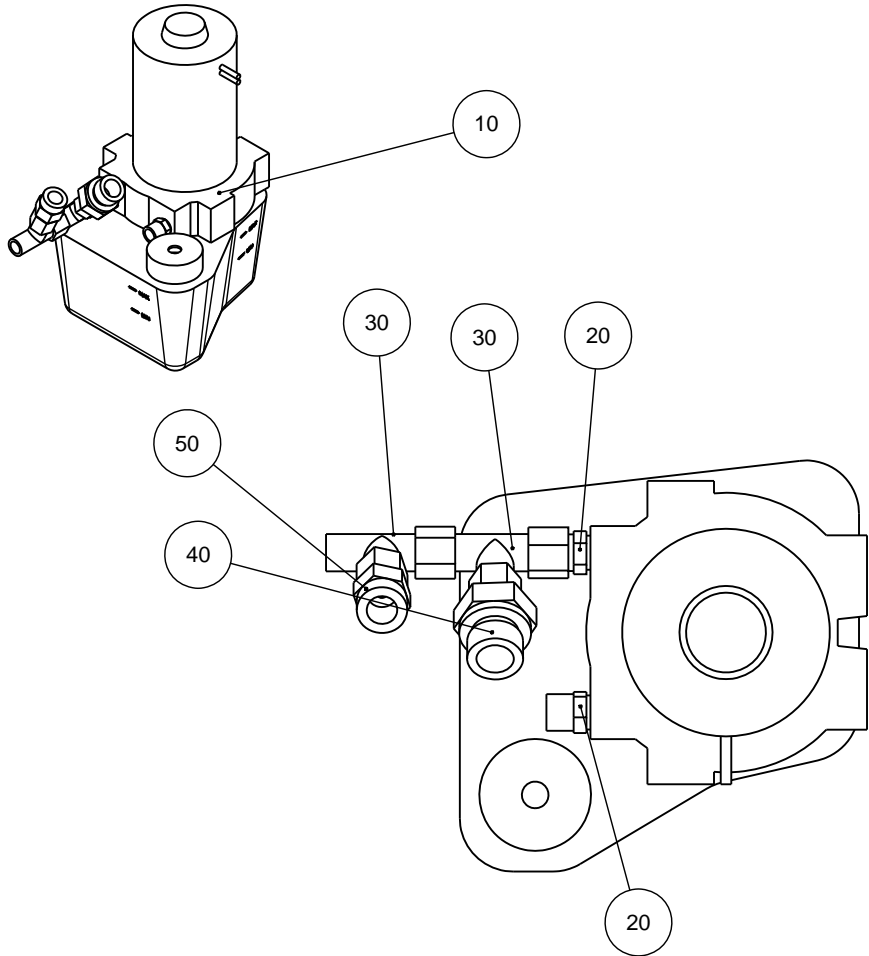
 Pederstrupvej 84 DK-2750 Ballerup/Copenhagen Denmark Phone: +45 44 600 800 Fax: +45 44 600 804	Material:	Scale: 1:2	Format: A3	Tolerance: DS/ISO 2768- Surface treat.: Non
	ID: 15740065 Electronic, assembled	Description:	Rev: B	



POS. NO.	AMOUNT	DRAW. NO.	NOTE
10	1	2YP70109 Hydr. Pump 36Vdc,1.1liter_min	
20	2	2NH01018 Male stud connector 1-8 M14	
30	2	2NH01014 T-swivel w. nut run M14	
40	1	2NH01024 Swivel conn.w.nut run 1-2 M14	
50	1	2NH01020 Swivel conn. w. nut run 1-4 M14	

B	2015-01-30	new pos. 10 2YP70109	OCR	2015-01-30	FTH / JTV
A	2006-04-12		BMJ	FTH	2006-12
Rev	Crea. date yyyy-mm-dd	Revision description	Draw. Init	Appr. date yyyy-mm-dd	Appr. Init
F	 Pederstrupvej 84 DK-2750 Ballerup Copenhagen Denmark Phone : +45 44600 800 Fax : +45 44600 804	 Material:	Scale: 1:2	Format: A4	Tolerance: DS/ISO 2768 - mK Weight : g
		ID: Description: 15730062 Pump unit, assembled			

A

B



C

D

E

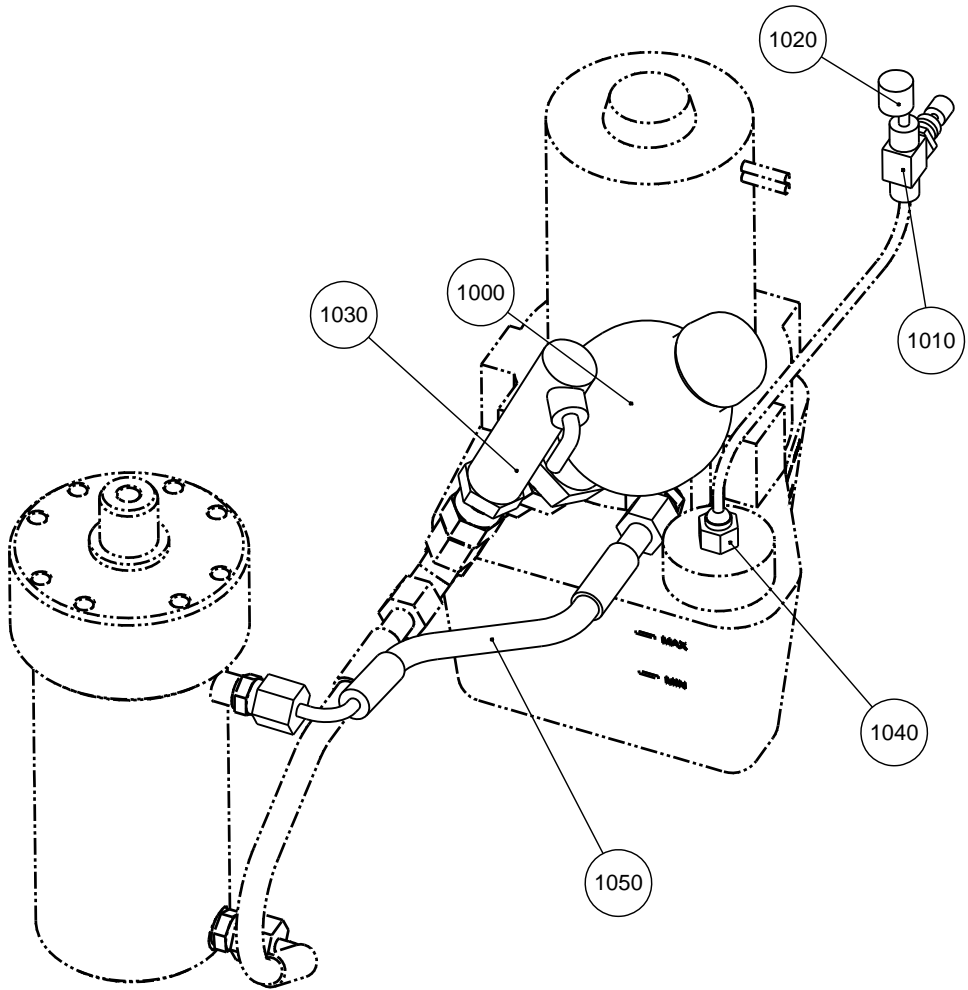
F



B	2015-02-02	new pos. 1000 2YA00726	OCR	215-02-02	FTH / JTV
A	24-08-07		JLI	24-08-07	FTH
Rev	Crea. date yyyy-mm-dd	Revision description	Draw. Init	Appr. date yyyy-mm-dd	Appr. Init
		 Material:	Scale: 1:2	Format: A4	Tolerance: DS/ISO 2768 - - Weight : g
Pederstrupvej 84 DK-2750 Ballerup Copenhagen Denmark Phone : +45 44600 800 Fax : +45 44600 804		ID: Description: 15730063 Hydraulic components for bottom			Rev: B

A

B

C

D

E

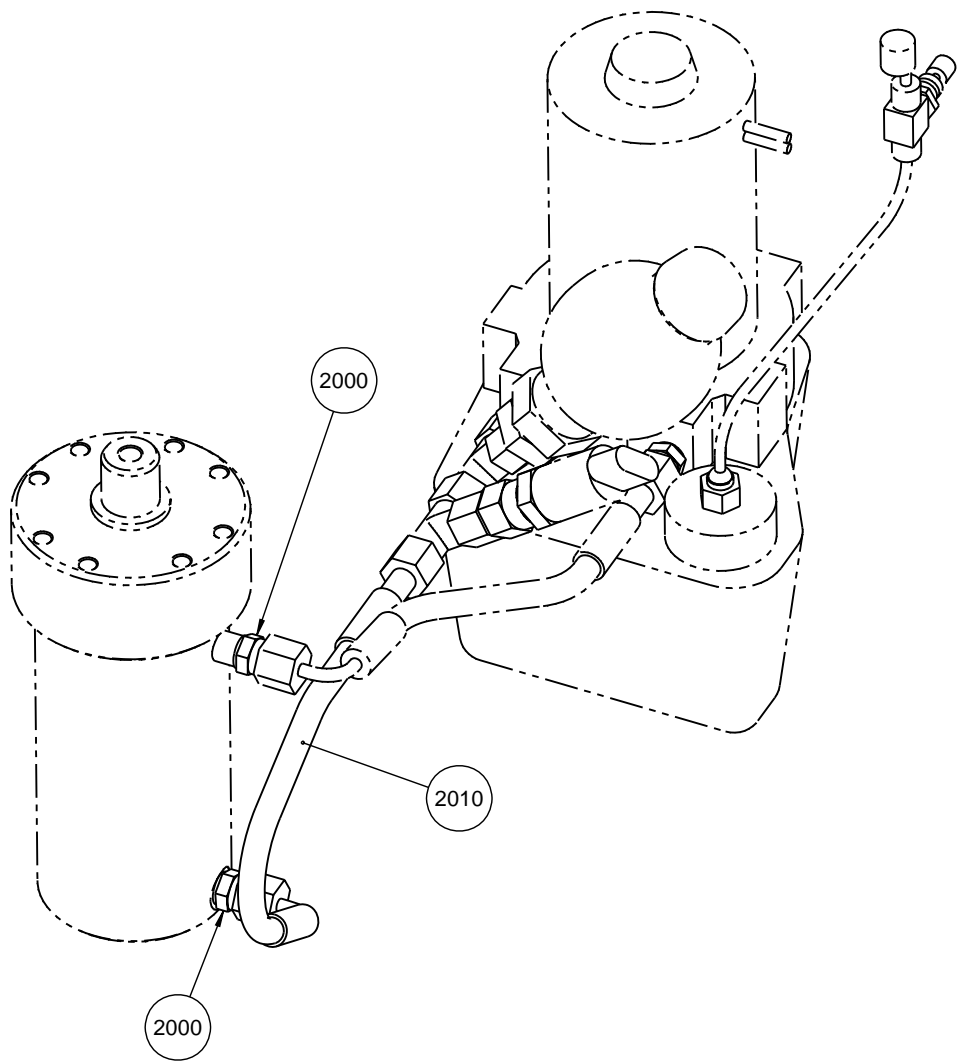

C					
B					
A	24-08-07			JLI	
Rev	Crea. date dd-mm-yy	Revision description	Draw. Init	Appr. date dd-mm-yy	Appr. Init
F	 Struers Pederstrupvej 84 DK-2750 Ballerup Copenhagen Denmark Phone: +45 44600 800 Fax: +45 44600 804	Material:	Scale: 1:2	Format: A4	Tolerance: DS/ISO 2768 - - Surface treat.: None
		ID: 15730064	Description: Hydraulic components for tower	Rev: A	

Seen without left tower.
Set uden venstre tårn.

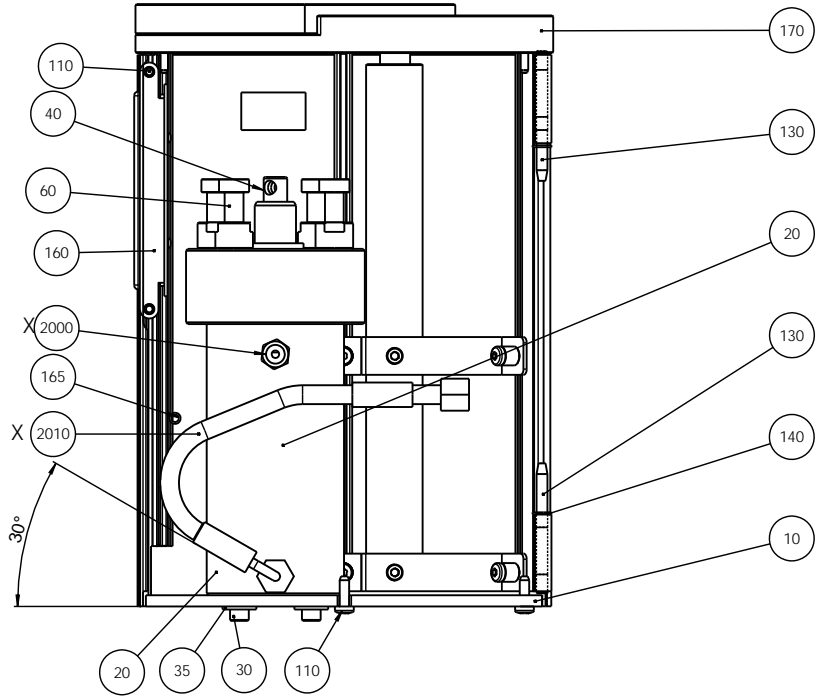

Seen without left tower hatch.
Set uden venstre tårns låge.

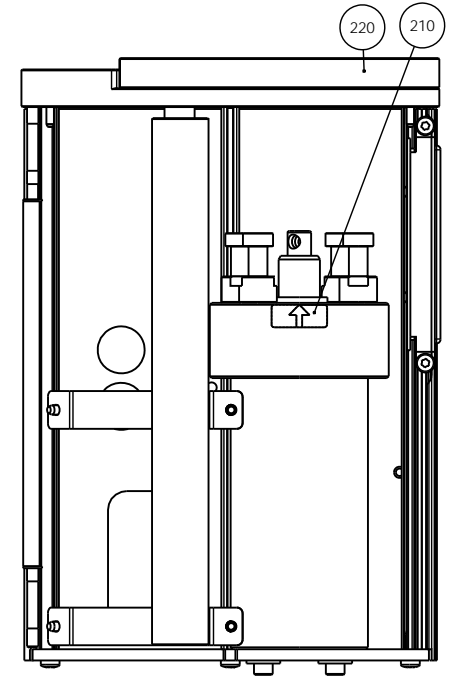
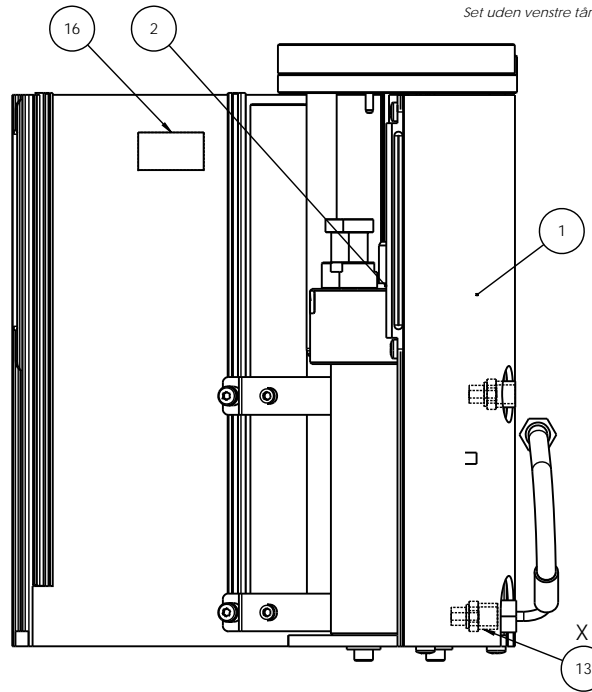

X: See part list 15730064

X: Se styklister 15730064

20 60 Glued with Loctite 648
Limes med Loctite 648

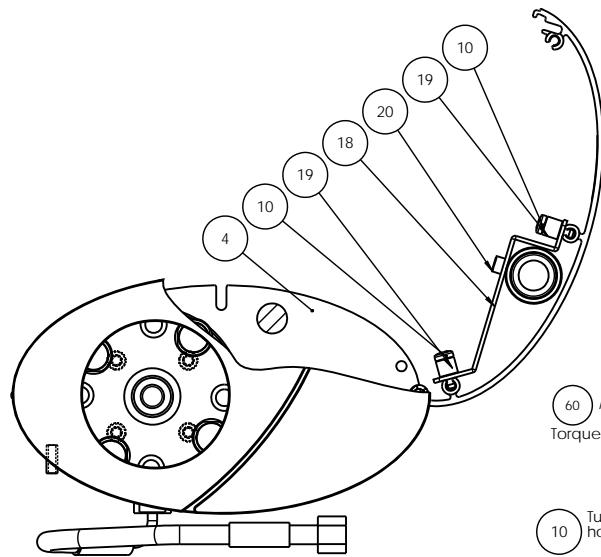

60 Moment 15Nm (±5%)
Torque 15Nm (±5%)

10 Turn bottom plate to point cylinder long holes against elevator

See 15737303, PF Tower

R	2015-06-02	new Moment 5Nm pos. 60	OCR	2015-06-02	JTV
A	30-01-06		BMJ		
Revision	Crea. date yyyy-mm-dd	Revision description	Draw. Init	Appr. date yyyy-mm-dd	Appr. Init
	Material:	Scale: 1:2	Format: A2	Tolerance: DS/ISO 2768- mK	g
				ID: Description:	
15730020 Left tower, assembled					R

Fabrikvej 14
 DK-2750 Ballerup/Copenhagen
 Denmark
 Phone: +45 44 800 800
 Fax: +45 44 800 904

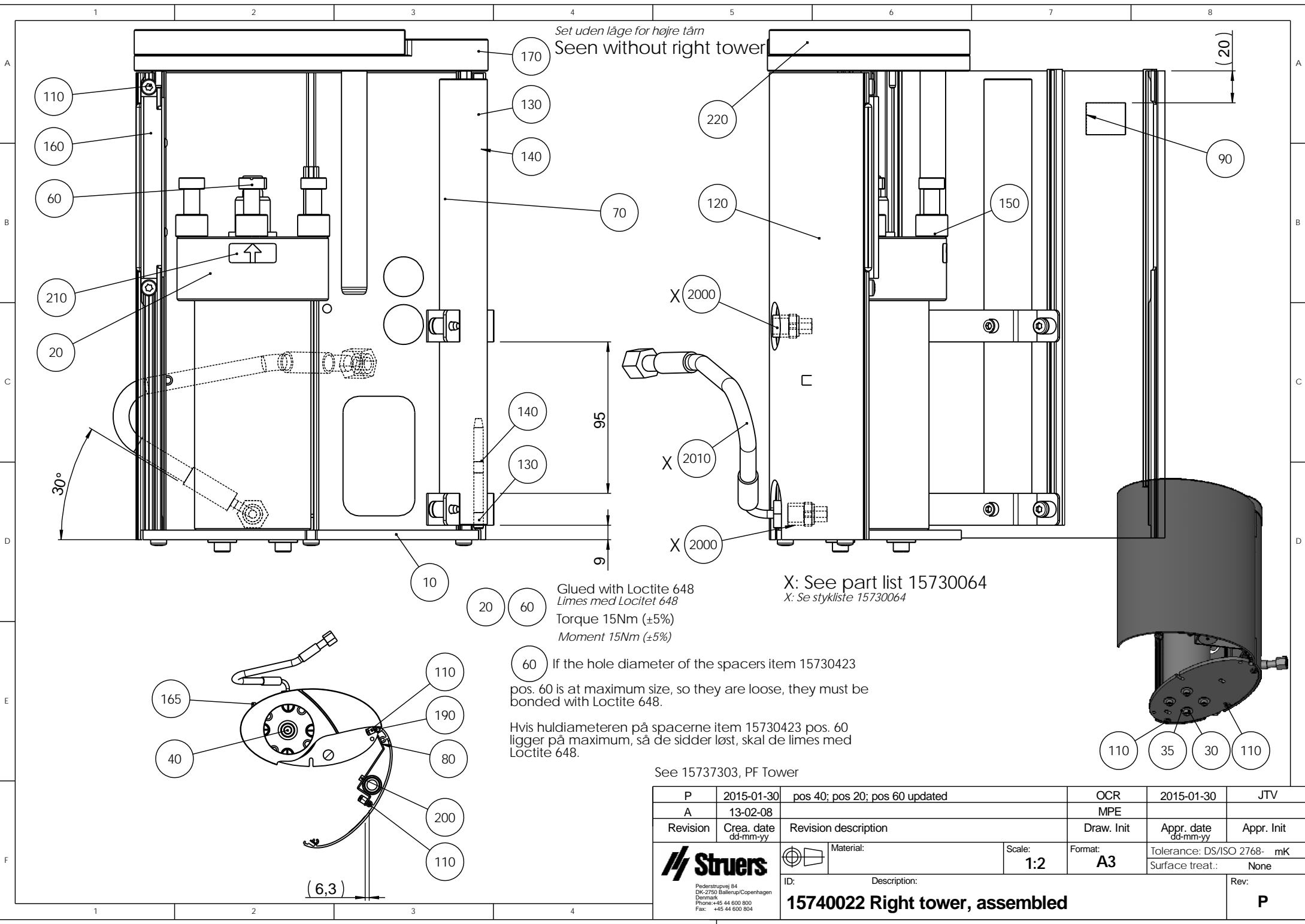

Set uden låge for højre tårn
Seen without right tower

Glued with Loctite 648
Limes med Locitet 648
Torque 15Nm (±5%)
Moment 15Nm (±5%)

60 If the hole diameter of the spacers item 15730423 pos. 60 is at maximum size, so they are loose, they must be bonded with Loctite 648.

Hvis hul diameteren på spacerne item 15730423 pos. 60 ligger på maximum, så de sidder løst, skal de limes med Loctite 648.

X: See part list 15730064
X: Se stykliste 15730064

See 15737303, PF Tower

P	2015-01-30	pos 40; pos 20; pos 60 updated	OCR	2015-01-30	JTV
A	13-02-08		MPE		
Revision	Crea. date dd-mm-yy	Revision description	Draw. Init	Appr. date dd-mm-yy	Appr. Init
 <small>Pederstrupvej 84 DK-2750 Ballerup/Copenhagen Denmark Phone: +45 44 600 800 Fax: +45 44 600 804</small>	 Material:	Scale: 1:2	Format: A3	Tolerance: DS/ISO 2768- mK	Rev:
				ID:	
15740022 Right tower, assembled			P		

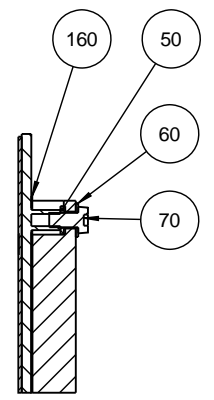
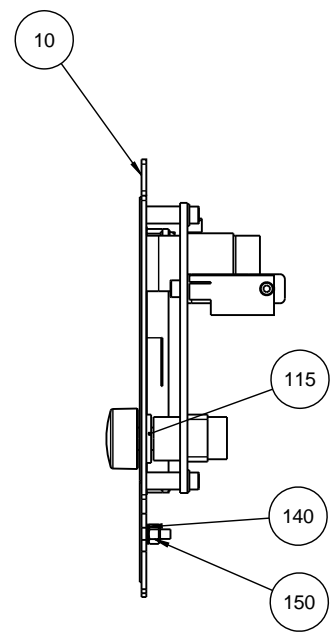
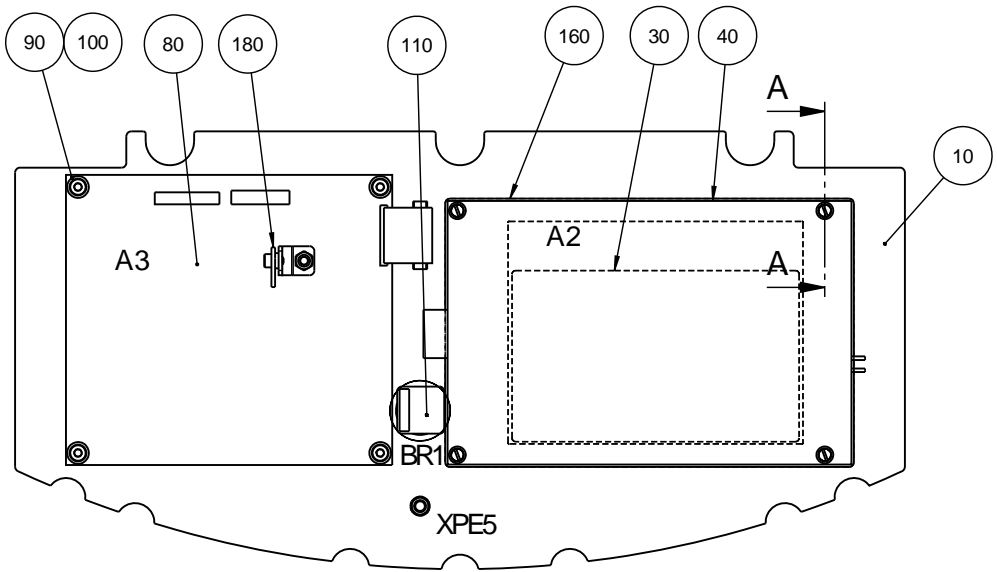

SECTION A-A
SCALE 1 : 1

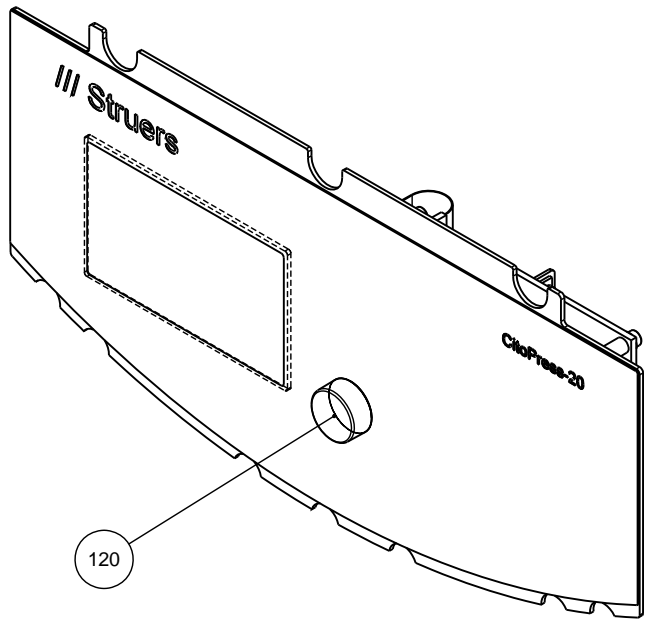

H	2012-01-27	(80) changed with new bracket for SMM.	BRY/SPE	2012-01-27	JTV
A	13-03-06		BMJ		
Revision	Crea. date dd-mm-yy	Revision description	Draw. Init	Appr. date dd-mm-yy	Appr. Init
		Material:	Scale: 1:2	Format: A3	Tolerance: DS/ISO 2768- mK
					Surface treat.: None
ID:		Description: 15740015 Frontplate, assembled			Rev: H

Pederstrupvej 84
 DK-2750 Ballerup/Copenhagen
 Denmark
 Phone: +45 44 600 800
 Fax: +45 44 600 804

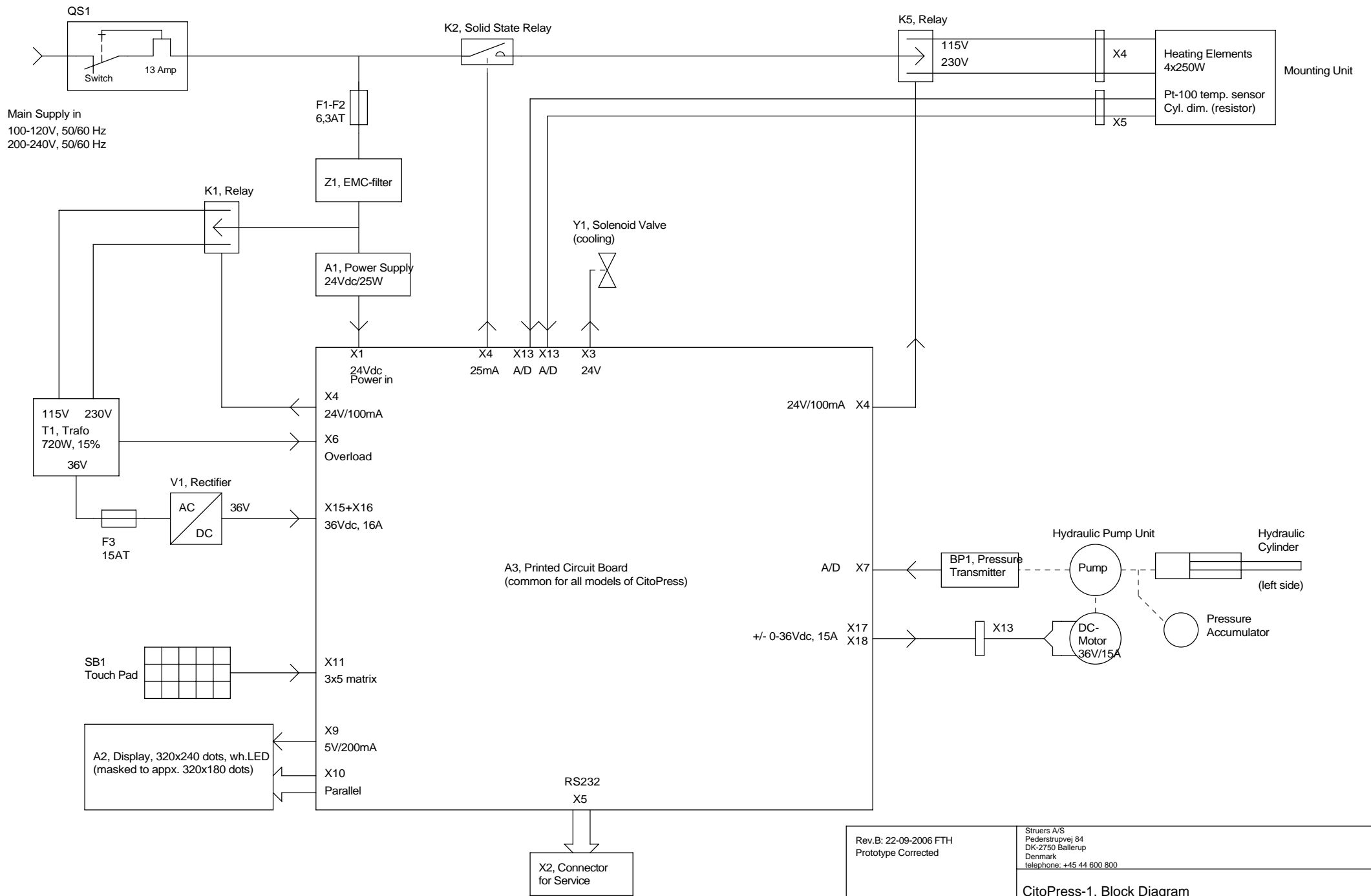

Rev.B: 22-09-2006 FTH Prototype Corrected		Struers A/S Pederstrupvej 84 DK-2750 Ballerup Denmark telephone: +45 44 600 800	
CitoPress-1, Block Diagram			
Size A3	CAGE Code	DWG NO 15733050	Rev B
Friday, October 13, 2006	Scale	FTH / FTH	Sheet 1 of 1

Main Supply Input:
 - 100-120V, 50/60Hz
 - 200-240V, 50/60Hz

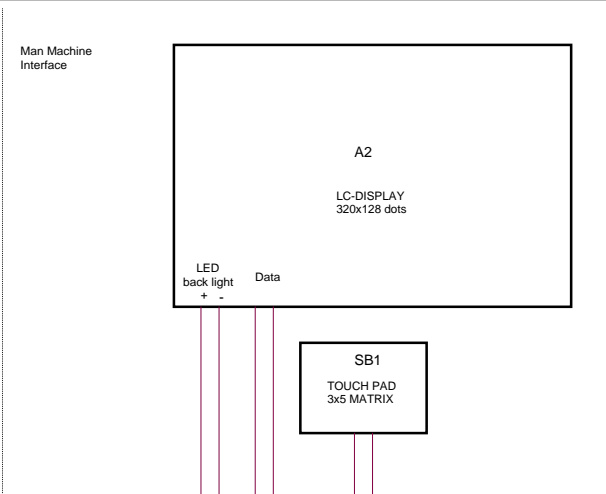
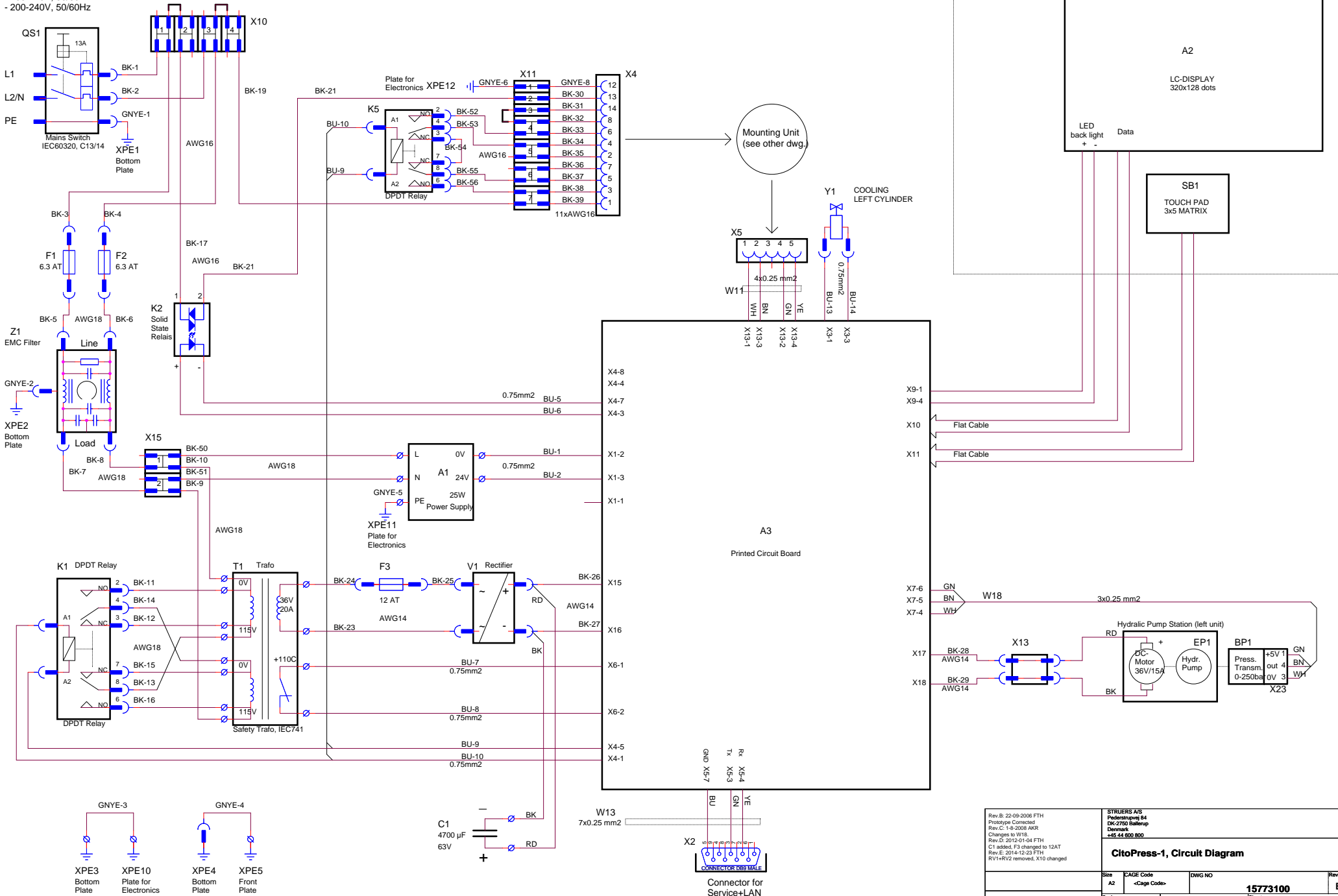

Rev.B: 22-09-2006 FTH Prototype Corrected Rev.C: 1-8-2008 AKR Changes to W18. Rev.D: 2012-01-04 FTH C1 added, F3 changed to 12AT Rev.E: 2014-12-23 FTH RV1+RV2 removed, X10 changed		STRUERS A/S Pederstrup 84 DK-2750 Ballerup Denmark +45 44 600 800	
CitoPress-1, Circuit Diagram			
Size	A2	CAGE Code	<Cage Code>
DWG NO			15773100
Scale			Sheet 1 of 1
Wednesday, January 14, 2015			

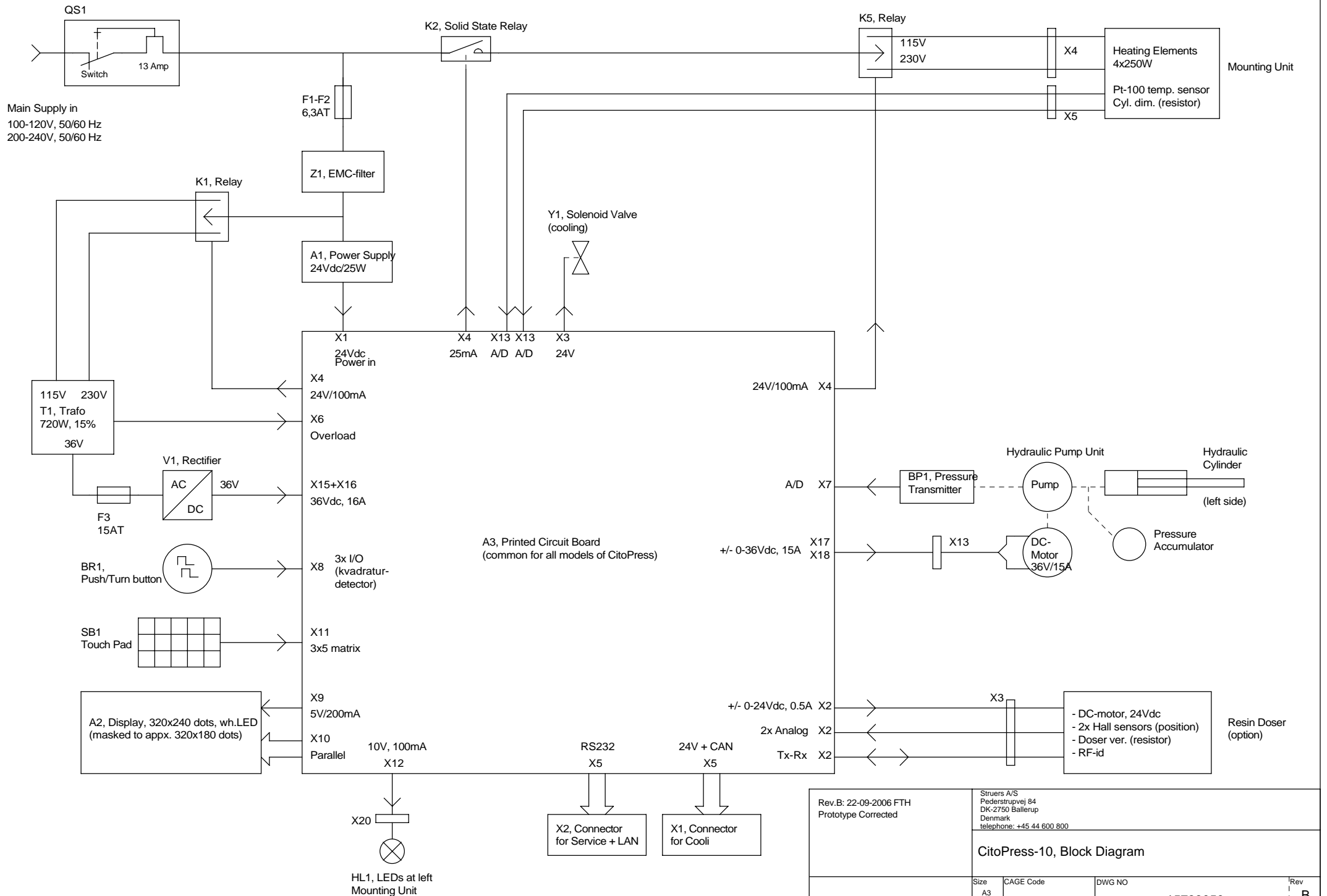

Rev.B: 22-09-2006 FTH Prototype Corrected		Struers A/S Pederstrupvej 84 DK-2750 Ballerup Denmark telephone: +45 44 600 800	
CitoPress-10, Block Diagram			
Size A3	CAGE Code	DWG NO 15733050	Rev B
Tuesday, September 26, 2006		Scale	Sheet 1 of 1

Main Supply Input:
 - 100-120V, 50/60Hz
 - 200-240V, 50/60Hz

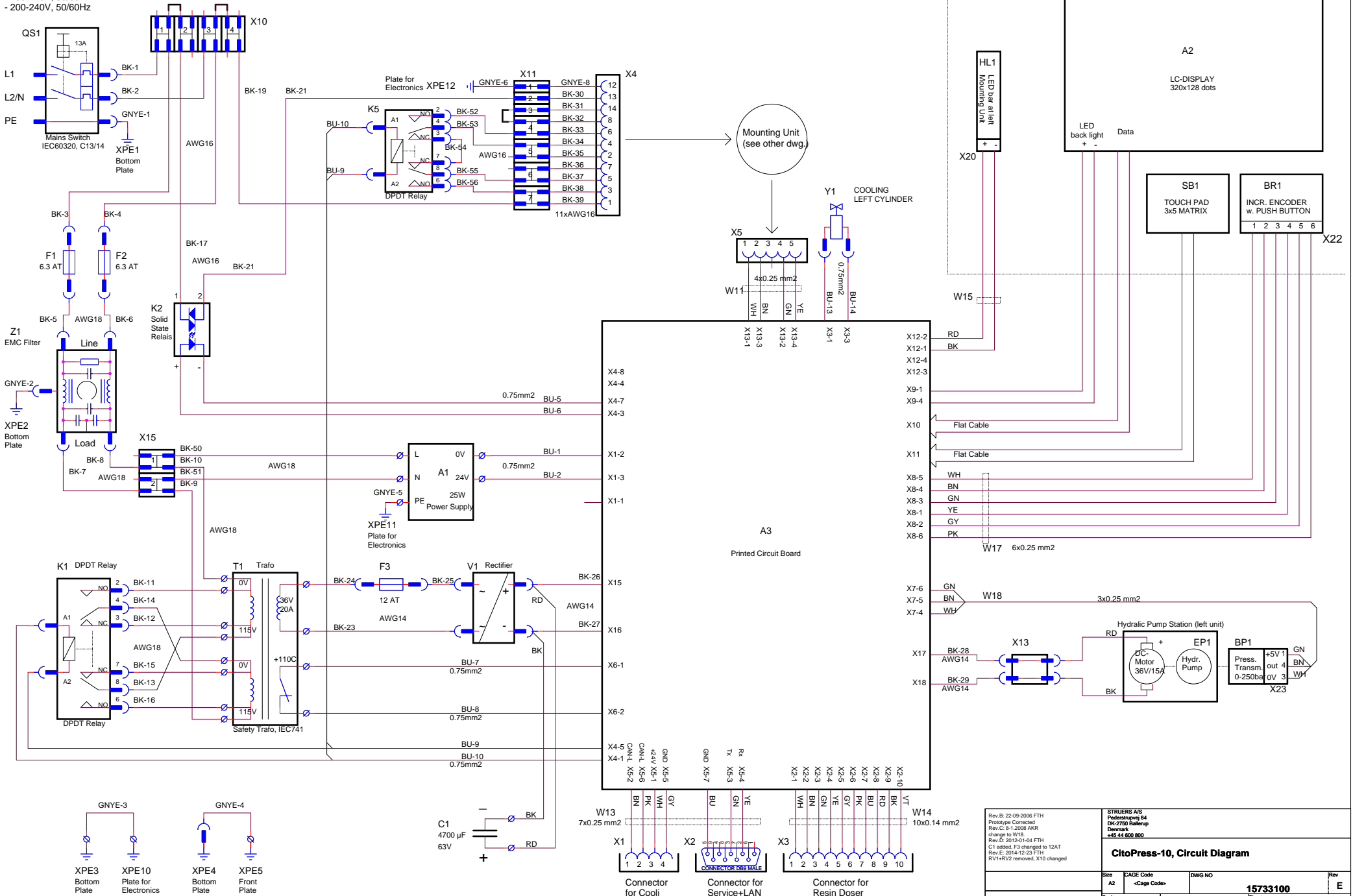

Rev.B: 22-09-2006 FTH Prototype Corrected Rev.C: 6-1-2008 AKR change to W18. Rev.D: 2012-01-04 FTH C1 added, F3 changed to 12AT Rev.E: 2014-12-23 FTH RV1+RV2 removed, X10 changed		STRUERS A/S Pederstrupsg 84 DK-2750 Ballerup Denmark +45 44 600 800	
CitoPress-10, Circuit Diagram			
Size	CAGE Code	DWG NO	Rev
A2	<Cage Code>		E
Scale		15733100	Sheet 1 of 1
Wednesday, January 14, 2015			

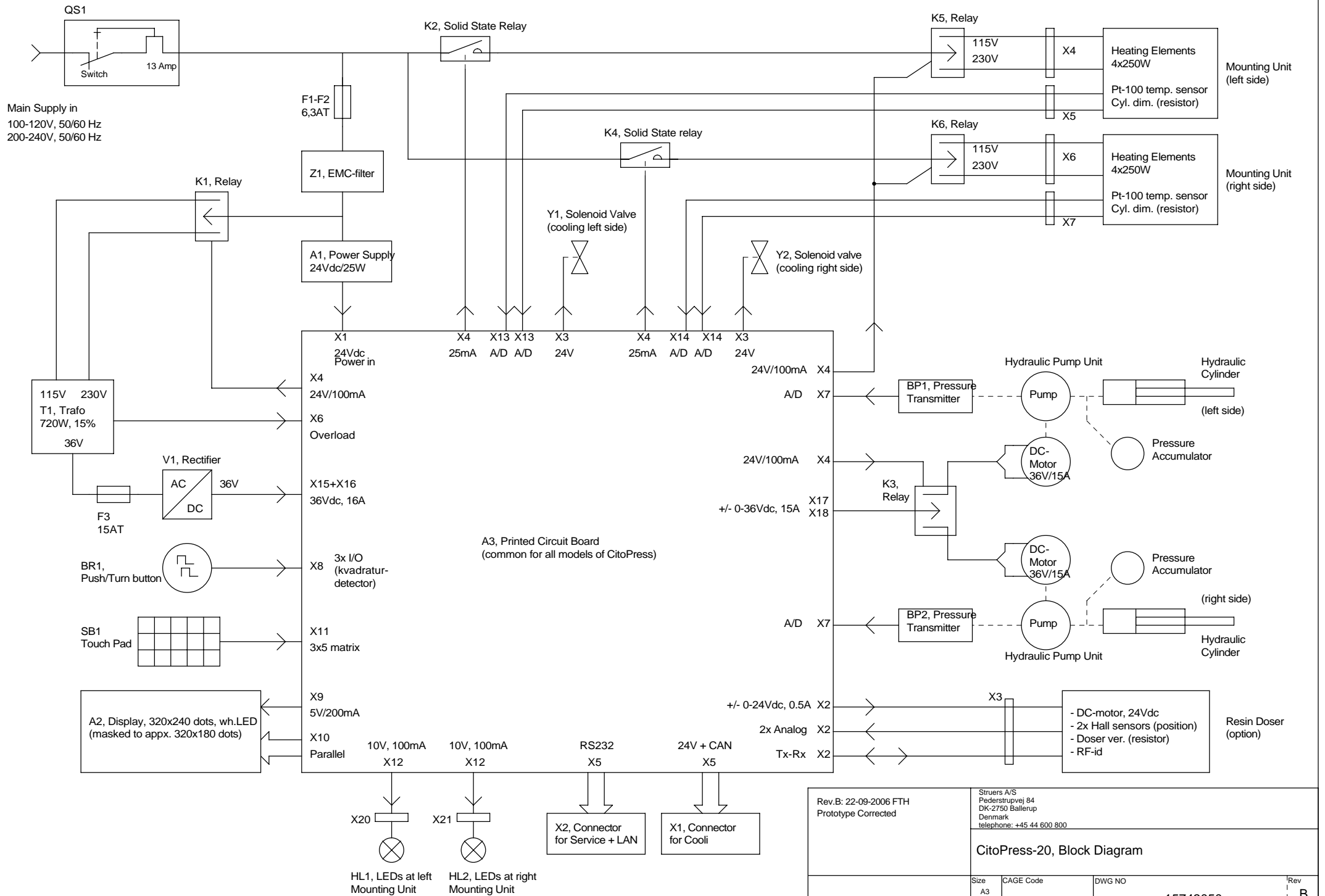

Rev.B: 22-09-2006 FTH Prototype Corrected	Struers A/S Pederstrupvej 84 DK-2750 Ballerup Denmark telephone: +45 44 600 800		
	CitoPress-20, Block Diagram		
Size A3	CAGE Code	DWG NO	Rev B
Tuesday, September 26, 2006	Scale	Sheet 15743050	Sheet 1 of 1

Main Supply Input:
 - 100-120V, 50/60Hz
 - 200-240V, 50/60Hz

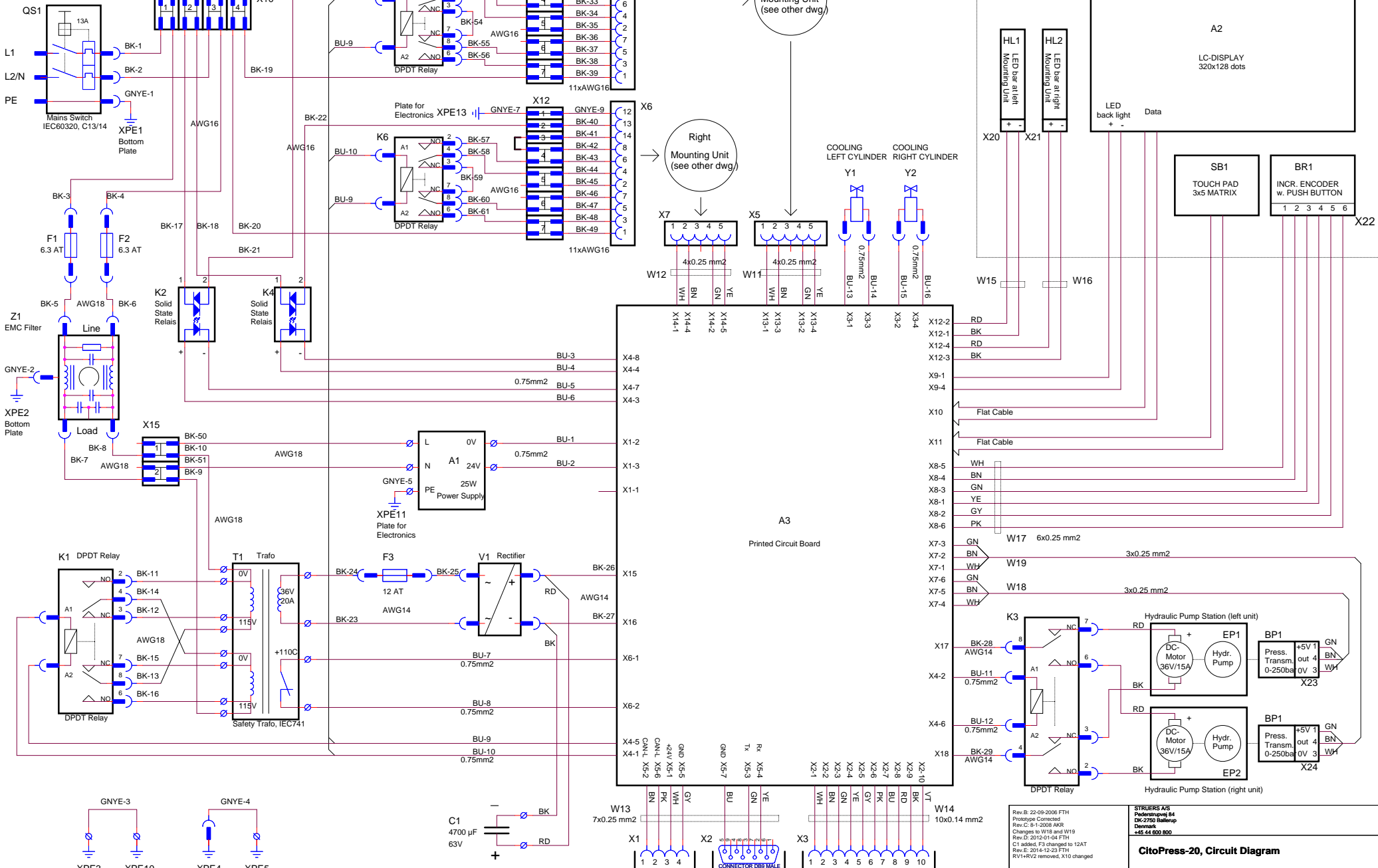

Rev. B: 22-09-2006 FTH
 Prototype Constructed
 Rev. C: 8-1-2008 ANR
 Changes to W18 and W19
 Rev. D: 2012-01-04 FTH
 C1 added, F3 changed to 12AT
 Rev. E: 2014-12-23 FTH
 RV1+RV2 removed, X10 changed

CitoPress-20, Circuit Diagram

Size	A2	CAGE Code	<Cage Code>	DWG NO	15743100	Rev	E
Scale				Sheet	1	of	1

Wednesday, January 14, 2015



Pederstrupvej 84
DK-2750 Ballerup
Denmark