

Secotom-15

Instruction Manual



Manual No.: 15997002

Date of Release 2017.02.01



Table of Contents	Page
User's Guide	1
Reference Guide.....	34
Quick Reference	48

Always state *Serial No* and *Voltage/frequency* if you have technical questions or when ordering spare parts. You will find the *Serial No.* and *Voltage* on the type plate of the machine itself. We may also need the *Date* and *Article No* of the manual. This information is found on the front cover.

The following restrictions should be observed, as violation of the restrictions may cause cancellation of Struers legal obligations:

Instruction Manuals: Struers Instruction Manuals may only be used in connection with Struers equipment covered by the Instruction Manual.

Service Manuals: Struers Service Manuals may only be used by a trained technician authorized by Struers. The Service Manual may only be used in connection with Struers equipment covered by the Service Manual.

Struers assumes no responsibility for errors in the manual text/illustrations. The information in this manual is subject to changes without notice. The manual may mention accessories or parts not included in the present version of the equipment.

Original instructions. The content of this manual is the property of Struers. Reproduction of any part of this manual without the written permission of Struers is not allowed.

All rights reserved. © Struers 2017.

Struers
Pederstrupvej 84
DK-2750 Ballerup
Denmark
Telephone +45 44 600 800
Fax +45 44 600 801



Secotom-15 Safety Precaution Sheet

To be read carefully before use

1. The operator(s) should be fully instructed in the use of the machine, any connected accessories and the applied consumables according to the relevant Instruction Manuals and Material Safety Data Sheets.
2. The machine must be placed on a safe and stable support table which is able to carry at least 80 kg / 176 lb. All safety functions and covers of the machine must be intact and in working order.
3. The machine must be installed in compliance with local safety regulations.
4. Keep your hands clear of the cutting table when moving the table.
5. Mind the protruding safety catch when the cover is raised.
6. The workpiece must be securely fixed in a clamping device. Large or sharp workpieces must be handled in a safe way.
7. Cut-off wheels must be approved for min. 5,000 rpm.
8. Observe the current safety regulations for handling and disposal of the additive for cooling fluid.
9. Consumables: only use consumables specifically developed for use with this type of materialographic machine.
To achieve maximum safety and lifetime of the machine, use only original Struers consumables.
10. Struers recommends using cooling fluid when cutting as the materials being cut may emit harmful dust. Additionally an adequate exhaust system should be used.
11. The machine emits only moderate noise. However, the cutting process itself may emit noise, depending on the nature of the workpiece. In such cases, the use of hearing protection is recommended.
12. The machine must be disconnected from the mains prior to any service. Wait 5 minutes until residual potential is discharged.

Secotom-15
Instruction Manual

- 13.** Do not cycle mains power more than once every three minutes.
Damage to the drive will result.
- 14.** Use of working gloves is recommended as workpieces may be both very hot and produce sharp edges.
- 15.** Use of safety shoes is recommended when handling large or heavy workpieces.
- 16.** Use of safety goggles is recommended when using the flushing hose.
Only use the flushing hose for cleaning *inside* the cutting chamber.

The equipment should only be used for its intended purpose and as detailed in the Instruction Manual.

The equipment is designed for use with consumables supplied by Struers. If subjected to misuse, improper installation, alteration, neglect, accident or improper repair, Struers will accept no responsibility for damage(s) to the user or the equipment.

Dismantling of any part of the equipment, during service or repair, should always be performed by a qualified technician (electromechanical, electronic, mechanical, pneumatic, etc.).

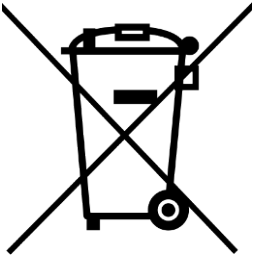

Disposal

Equipment marked with a WEEE symbol  contain electrical and electronic components and must not be disposed of as general waste.

Please contact your local authorities for information on the correct method of disposal in accordance with national legislation.

User's Guide

Table of Contents	Page
1. Getting Started	
Checking the Contents of the Packing Box.....	3
Removing Secotom-15 from the Pallet.....	3
Placing Secotom-15.....	3
Getting Acquainted with Secotom-15.....	4
Rear of Secotom-15.....	5
Supplying Power.....	6
Mounting the Cut-off Wheel.....	7
Adjusting the Height of the Cut-off Wheel.....	8
Filling the Cut-off Machine with Cooling Fluid.....	9
Water Sensitive Materials.....	9
Optimising Cooling.....	10
Cutting Table.....	11
Positioning the Cutting Table.....	11
Attaching Clamping Tools (accessories).....	12
Quick-clamping and Spring Clamp Devices.....	12
Stands for Specimen Holders.....	13
Electrical Connections in the Cutting Chamber.....	14
Flushing Hose.....	15
Drain Basket.....	15
Connection to an External Exhaust System.....	16
2. Basic Operation	
Control Panel.....	18
Switching on for the first time.....	19
Zero Positions.....	20
Changing/Editing Values.....	21
Main menu.....	23
Cutting methods.....	24
Return position.....	26
Maintenance.....	27
Configuration.....	28
Manual X-stand, accessory.....	29
Rotary stand, accessory.....	29
Starting the Cutting Process.....	31
Stopping the Cutting Process.....	31

3. Routine Maintenance

Daily Service	32
Weekly Service	32
Checking the Recirculation Cooling Unit.....	32
Yearly Service	32
Inspection of Cover	32
Cut-off Wheels	33
Dressing Cut-off Wheels	33

1. Getting Started

Checking the Contents of the Packing Box

In the packing box you should find the following parts:

- 1 Secotom-15
(Precision cut-off machine for cutting of larger workpieces)
- 2 Mains cables
- 1 Stop pin
- 1 Socket spanner 17 mm
- 1 Hose for connection to exhaust, 1.5 m x 51 mm dia.
- 1 Hose clamp, 40-60 mm dia.
- 1 Instruction Manual Set

Removing Secotom-15 from the Pallet

- Remove the eight coach bolts with a 4 mm Allen key from the two transport brackets that secure Secotom-15 to its transport pallet.
- Remove the brackets.
- Lift Secotom by holding underneath the base of the machine, on the left side and on the right side.

Placing Secotom-15

Secotom-15 should be placed on a safe and stable support table with an adequate working height. The table must be able to carry at least 80 kg / 176 lb. The machine must be placed close to the power supply.

Check that the Secotom-15 is resting securely with all 4 rubber feet on the table.

**Getting Acquainted with
Secotom-15**

Take a moment to familiarise yourself with the location and names of the Secotom-15 components.

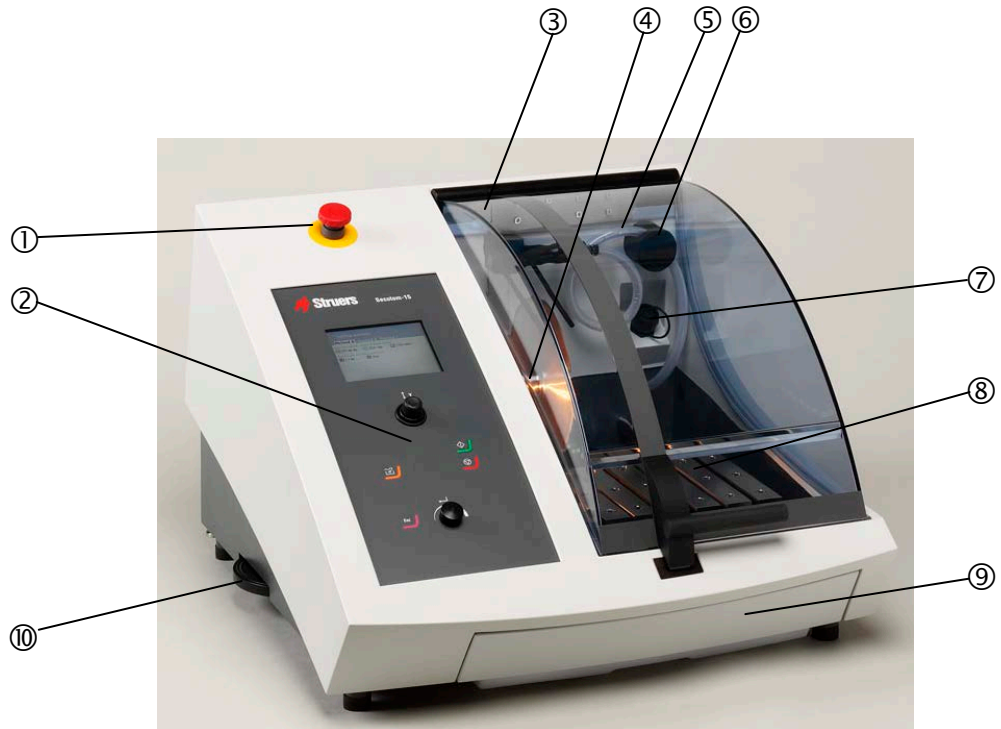

- ① Emergency Stop
- ② Control panel (details in section 2. Basic Operation)
- ③ Cover
- ④ Cut-off wheel spindle
- ⑤ Flushing Hose
- ⑥ Holder for Flushing Hose / Exhaust
- ⑦ Electrical connection socket
- ⑧ Movable cutting table
- ⑨ Cooling fluid tank
- ⑩ Wheel for adjusting the height of the cut-off wheel

Rear of Secotom-15

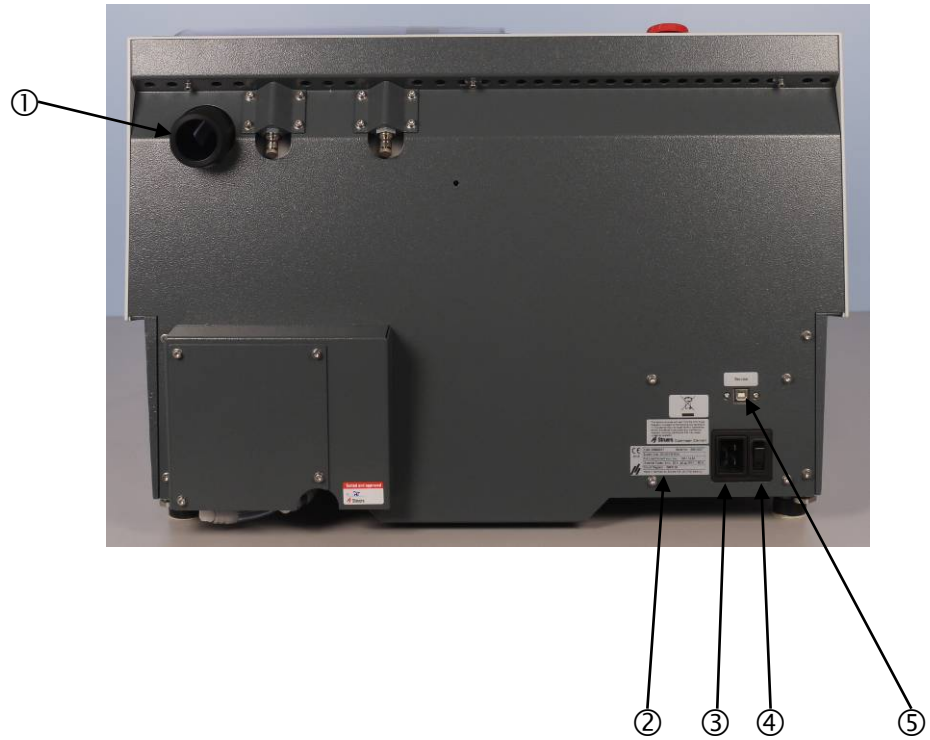

- ① Ventilation Flange for Exhaust
- ② Type Plate
- ③ Mains connection
- ④ Main switch
- ⑤ Service socket

Supplying Power

Always remember to switch the power off when installing electrical equipment!



IMPORTANT
Check that the mains voltage corresponds to the voltage stated on the type plate on the back of the machine.

The Secotom-15 is shipped with 2 types of Mains cables:

Single-phase Supply

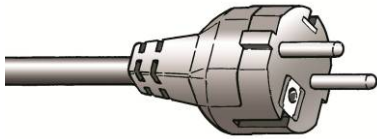

The 2-pin (European Schuko) plug is for use on single-phase, 200-240 V connections.

If the plug supplied on this cable is not approved in your country, then the plug must be replaced with an approved plug. The leads must be connected as follows:

Yellow/green: earth
Brown: line (live)
Blue: neutral

2-phase Supply



The 3-pin (North American NEMA) plug is for use on 2-phase, 200-240 V power connections.

If the plug supplied on this cable is not approved in your country, then the plug must be replaced with an approved plug. The leads must be connected as follows:

Green: earth
Black: line (live)
White: line (live)

Connection to the Machine

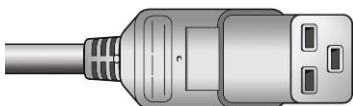

Both cables are equipped with an IEC 320-C19 cable connector that has to be connected to the Secotom.

WARNING!
The output voltage from this cable is 200 – 240V and not 110V. DO NOT use this cable to connect equipment that use a 110V power supply. Failure to adhere to this may result in material damage.

Mounting the Cut-off Wheel

- Lift the cover to the "open" position (the position where it will stay up and open when released).

NB

Mind the protruding safety catch when the cover is raised.

- Lift the cooling fluid nozzles to gain access to the cut-off wheel mounting.

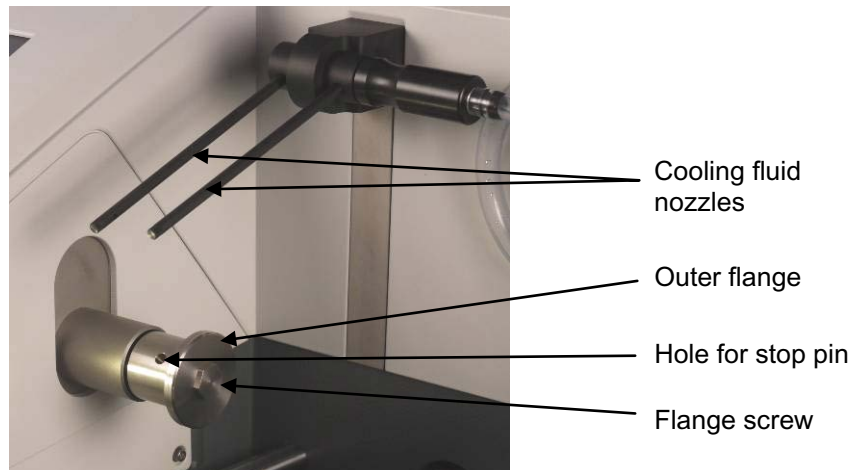

- Insert the stop pin into the hole on the cut-off wheel spindle.
- Use the socket spanner 17 mm to loosen the flange screw.



- Remove the outer flange.

IMPORTANT

The tolerance between the spindle and inner flange is very small which means that the two surfaces must be absolutely clean. Never try to squeeze the cut-off wheel on as this may damage the spindle or the cut-off wheel. If there are any small burrs, remove them with grinding paper grit size 1200.

IMPORTANT

When mounting cut-off wheels with a 12.7 mm centre hole, make sure that the 22 mm arbour insert has been removed. Failure to do this will result in the cut-off wheel being pressed out of shape.

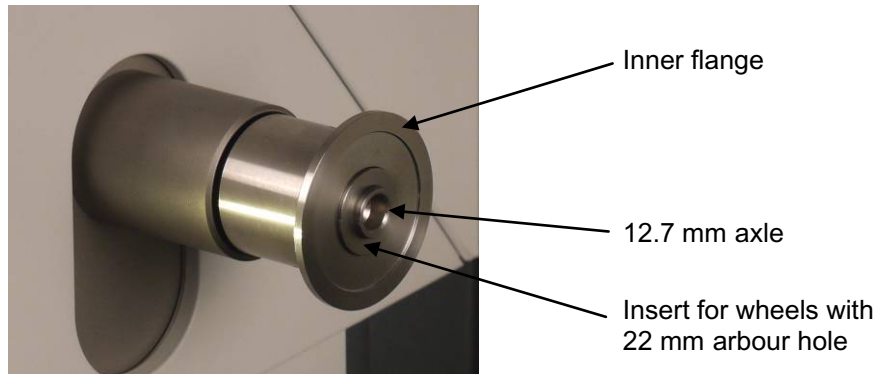

- Mount the cut-off wheel (using the 22 mm insert if necessary) and remount the outer flange, with the machined face towards the inner flange.
- Insert the locking pin in the hole in the inner flange. Gently fasten the flange screw using the socket spanner 17 mm. (The nut should be tightened with a force of maximum 5 Nm / 4 lbf-ft).
- Lower the cooling fluid nozzles to their operating positions.



Adjusting the Height of the Cut-off Wheel

The distance between the cut-off wheel spindle and the cutting table can be adjusted to suit the individual cut-off wheels or wear caused during the cutting process.

- Use the adjusting wheel on the left hand side of Secotom to raise and lower cut-off wheel.

Adjusting wheel



Filling the Cut-off Machine with Cooling Fluid

The Secotom-15 has a built-in cooling fluid system. The fluid coming from the nozzles passes over the cut-off wheel and collects in the drain in the cutting chamber; where it then returns to the tank, which is located under the cutting chamber.

- Slide the cooling fluid tank out gently.



- Remove the screw cap and pour out the used cooling fluid.
- Rinse the tank with clean water, periodically shaking the tank to release any debris that has accumulated on the bottom of the tank. Repeat the rinsing process until the tank is clean.
- Replace the screw cap.
- Fill the tank with a 3% solution of Struers additive, Corrozip: 140 ml Corrozip and 4.6 l water. For water-sensitive materials, use Struers Water-Free Cooling Fluid.
- Slide the tank back into position.

Water Sensitive Materials

Struers Water-free Cutting Fluid is available for use when sectioning materials which are sensitive to water.

Important!

The tube in the cooling fluid pump **MUST** be replaced by a special tube when using Water-free Cutting Fluid. The standard tube will only last for a few days as it will react with the Water-free Cutting Fluid. Tubes for Water-free Cutting are available as a Spare Part (Cat. No. 05996921).

For instructions on exchanging the tube, please see the section on [Changing Cooling Pump Tubes](#) in the Reference Guide section of the manual.

Optimising Cooling

Sufficient cooling is very important for ensuring the best cutting quality and to avoid burning of the workpiece and damaging the cut-off wheel.

Optimise cooling effect using the following tips:

- Always use additive to protect the cutting machine from corrosion and to improve cutting and cooling qualities.
- Ensure that there is sufficient water in the tank for optimal cooling.
- Maintain the correct concentration of Struers additive in the cooling water (percentage stated on the container of the Additive).
- Remember to add Struers additive each time you refill with water.
- It is recommended to change the cooling water at least once a month to prevent the growth of microorganisms.
- Struers recommends the use of Struers' own additives. **Do not** use oil, petrol, or turpentine-based additives, as they can affect the tubes for the cooling water.

Cutting Table

The Secotom-15 is fitted with a moving cutting table. Movement of the table is controlled using the joystick on the Control Panel and through the software, which is described in section 2. Basic Operation. The table has several 8 mm T-slots, which are used to secure clamping tools. This ensures that workpieces to be cut are held securely during the cutting process. Although these clamping tools are available as accessories, details about the table and the clamping tools are described in this and the following sections.

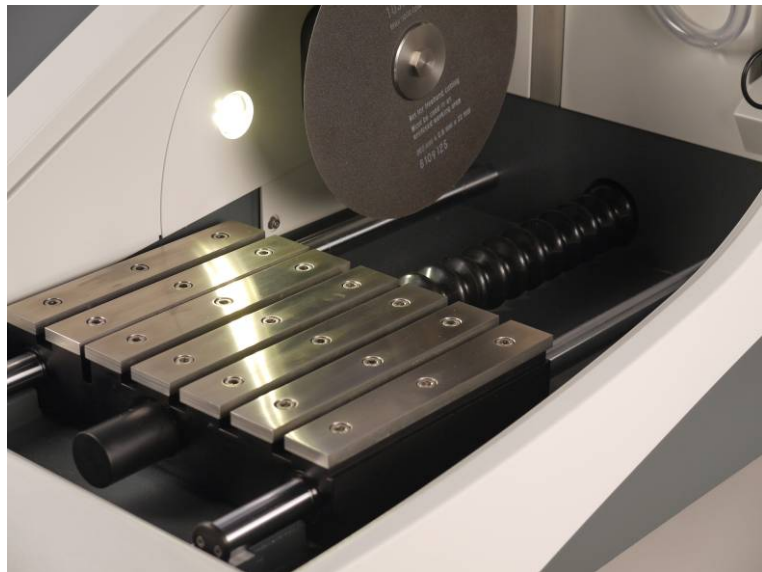

Positioning the Cutting Table

Although during the cutting process the table movement is controlled through Secotom-15's software, prior to starting the cutting process, it is necessary to position the cutting table manually.

NB!

Keep hands clear of the cutting table when moving the table.

- Use the joystick on the Control Panel to move the cutting table.
- Pull the joystick towards you to move the cutting table away from the cut-off wheel, or push the joystick away from you to move the cutting table towards the cut-off wheel.

Attaching Clamping Tools (accessories)

There are several types of clamping tools available as accessories (please refer to the [Secotom-15/-50 brochure](#) for details of the range available). Some of these are mounted directly on the cutting table while others with more sophisticated features, need to be fixed on a stand using a dovetail holder.

Important!

When fitting clamping tools, always ensure that they cannot come in contact with the cut-off wheel. Failure to do this may result in the clamping tools being damaged.

NB

Mind the protruding safety catch when the cover is raised.

Quick-clamping and Spring Clamp Devices

- Position the back stop and the clamping device as shown in the illustration.

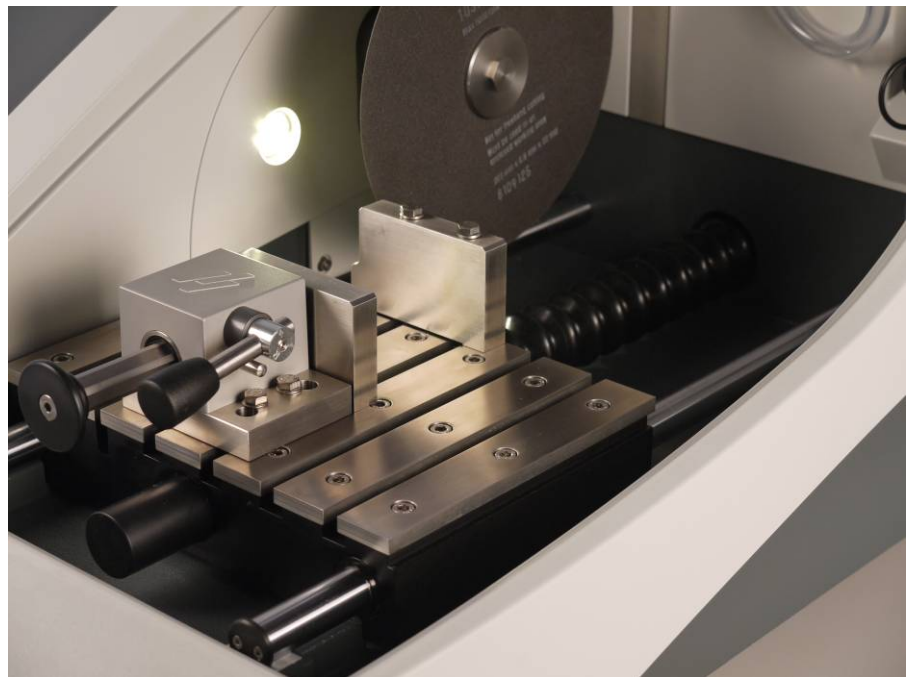

- Tighten the nuts to secure.

Stands for Specimen Holders

- Place the stand on the cutting table by sliding the securing bolts in the T-slot and tighten the nuts.
- For stands requiring an electrical supply: Connect the cable as described in [Electrical Connections in the Cutting Chamber](#) on the next page.
- Place the workpiece in the specimen holder.
- Fasten the specimen holder in the stand by sliding the dovetails into each other and fasten.

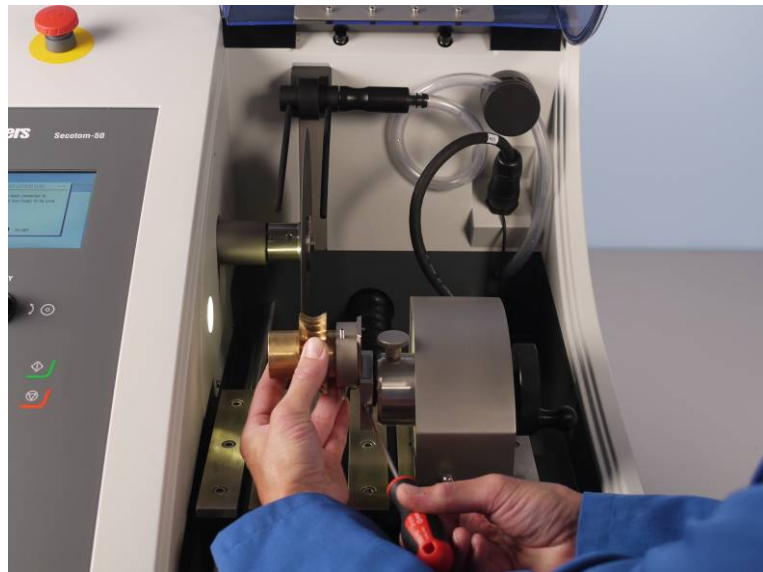

Electrical Connections in the Cutting Chamber

The Manual X-stand and the Rotary stand require electrical connections. These are supplied through the electrical connection socket in the cutting chamber.

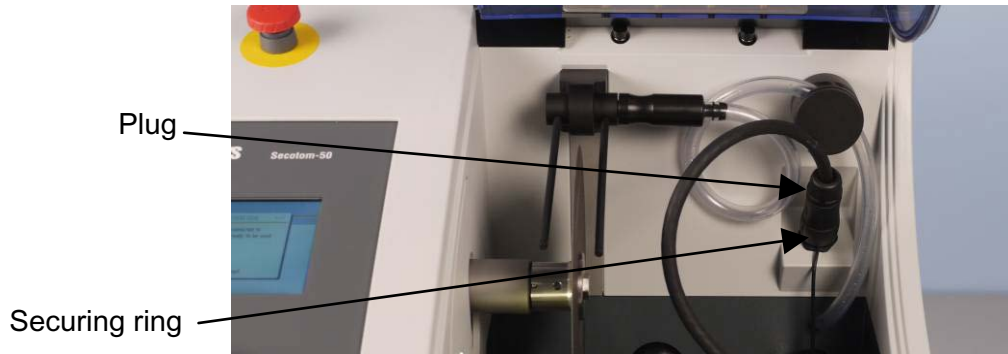

- Remove the cap on the electrical connection socket in the cutting chamber.
- Connect the accessory to the electrical connection socket.

Note

The different electrical accessories can be exchanged while Secotom-15 is switched on.

Note

The plugs on these accessories provide specific pin connections. If for some reason you have a problem with a connection, do not attempt to change the connections in the clamping tool plugs or connection socket.

- A pop-up on the display confirms that the accessory is now connected.
- Gently tighten the securing ring.

Important

Always replace the socket's cap when not in use.

Flushing Hose

The Secotom-15 comes complete with a flushing system. This enables the cutting chamber to be rinsed clean of any debris discarded during the cutting process. Flushing is operated through the Control Panel buttons.

Warning!

Do not start the flush function until you have removed the hose from the fluid nozzles and are pointing it into the cutting chamber.

- Remove the hose from the cooling fluid nozzles.



- Holding the hose in the cutting chamber, press FLUSH 
- To stop flushing, press FLUSH  again.

Important!

Remember to replace the hose in its holder when you have finished flushing the cutting chamber.

Drain Basket

Secotom is equipped with a basket in the drain to collect the larger particles from the cutting process and prevent them from blocking the tank.

Important:

Check the basket for cutting debris before starting the cutting process; a blocked drain can result in water overflow and too little water in the tank to secure a sufficient cooling.

Connection to an External Exhaust System

Struers recommends the use of an exhaust system as workpieces may emit harmful gases when cut. The unit is prepared for connection to an exhaust system via a 50 mm fitting at the rear of the cabinet.

- Mount an exhaust hose from your local exhaust system onto the ventilation flange at the rear of the machine.



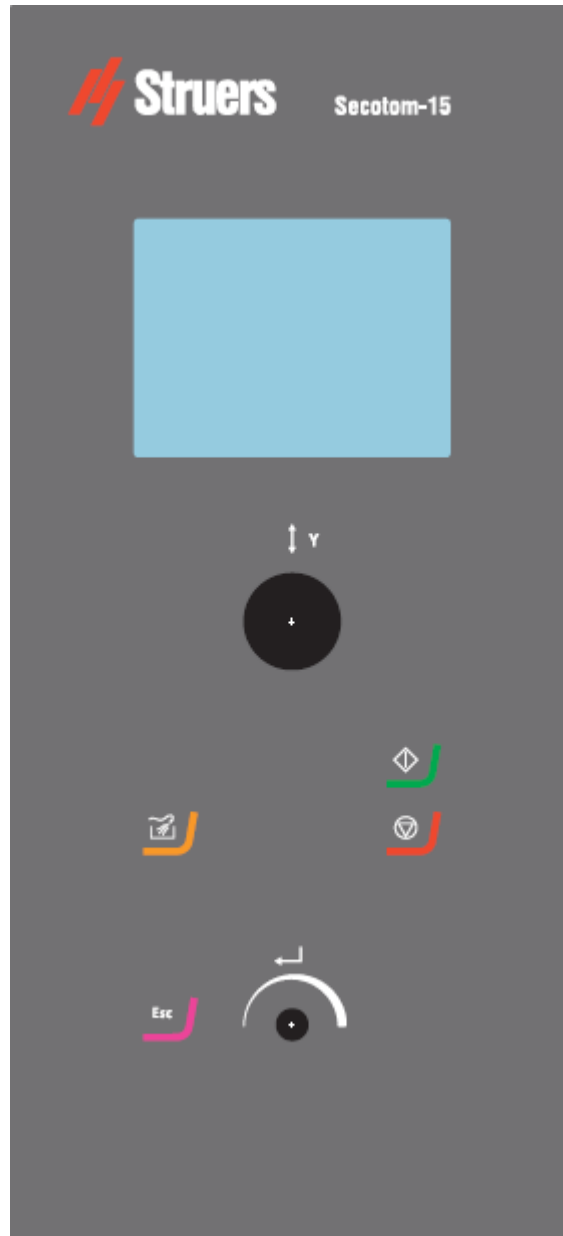

2. Basic Operation

Control Panel

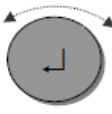

Control Panel

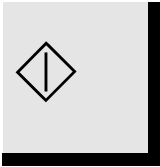
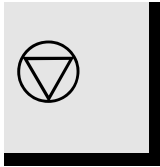
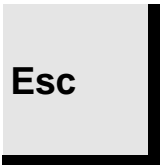
This provides information about the individual buttons on the control panel of the Secotom-15.

	Key	Function		Key	Function
Turn/Push knob		Multifunction knob Turn knob to move the cursor or to adjust settings. Push knob to select (ENTER)	Joystick		Move up- or downwards to position the cutting table
START		Starts the cutting process.	STOP		Stops the cutting process.
ESC		Leaves the present menu or aborts functions/changes.	FLUSH		Starts and stops the FLUSH operation.

Switching on for the first time

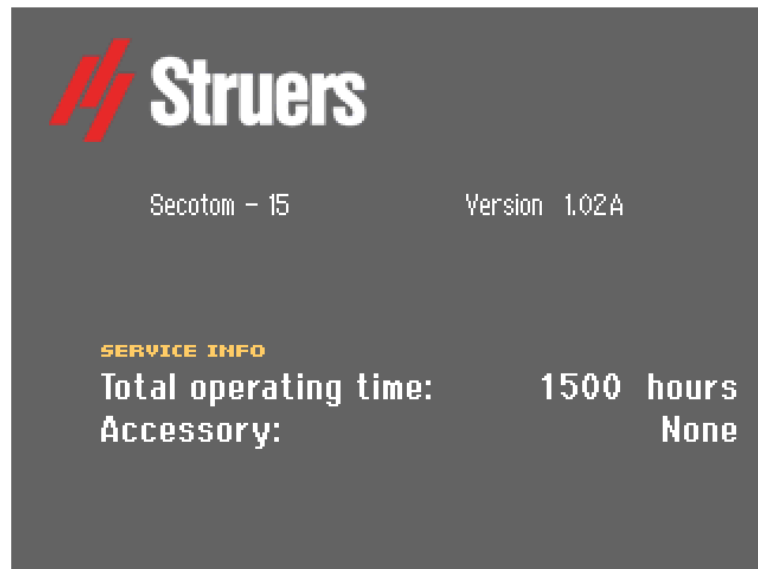

Switch on the power at the main switch located at the rear of the machine. The following display will appear briefly:

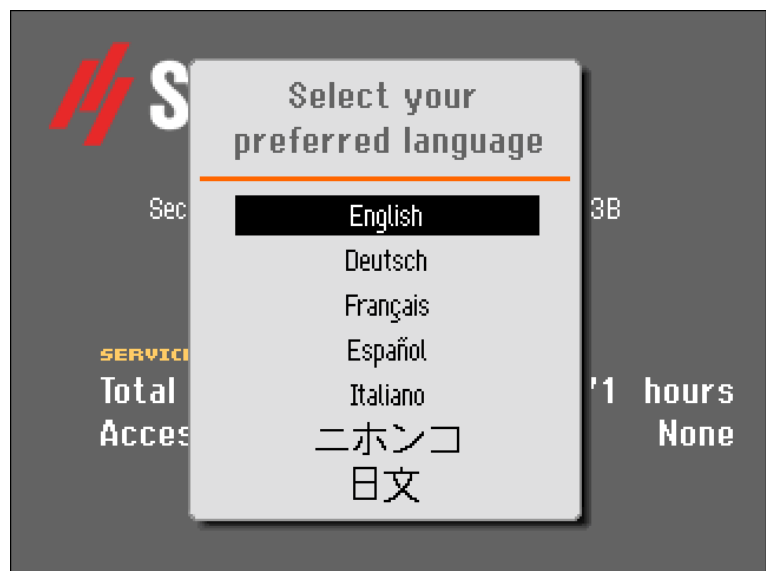

The display will then change to the last screen shown before the Secotom-15 was switched off.

When switching on Secotom-15 for the first time, the *Select language* screen will appear.



- ↓
-  Turn knob to select the language you prefer.
-  Push knob to accept the language.

You will now be prompted to set the time.





 Turn knob to select and to adjust the settings.

 Push knob to accept the settings.

You will now be prompted to set the date.



 Turn knob to select and to adjust the settings.

 Push knob to accept the settings.

 When Time and Date have been set, turn knob to select *Save and Exit*.

 Push knob to *Save and Exit* (Save the settings and return to the *Main menu*).

The *Main menu* now appears in the language you have chosen.

Zero Positions

Zero positions are calibrated after each 5th startup, **or** if reference positions have been lost.

- To manually reset zero positions, press the Emergency Stop button during startup.

Changing/Editing Values

Depending on the type of value, there are two different ways of editing.

Numeric Values

 Turn knob to select the value to be changed, e.g. *Wheel speed*:

 Push knob to edit the value.

A scroll box appears around the value.



 Turn knob to increase or decrease the numeric value.



 Push knob to accept the new value.
(Pressing **Esc** aborts the changes, preserving the original value.)

Alphanumeric Values

 Turn knob to select the alphanumeric value to be changed, e.g. *Return position*



 Push knob to edit the value.

A pop-up menu appears.



Turn knob to select the correct choice.



Push knob to accept the new selection and to continue or to return to the previous screen.
(Pressing Esc aborts the changes, preserving the original setting.)

Main menu

The *Main menu* is the highest level in the menu structure. From this menu, you can enter the *Cutting methods*, *Maintenance* and *Configuration* menus.

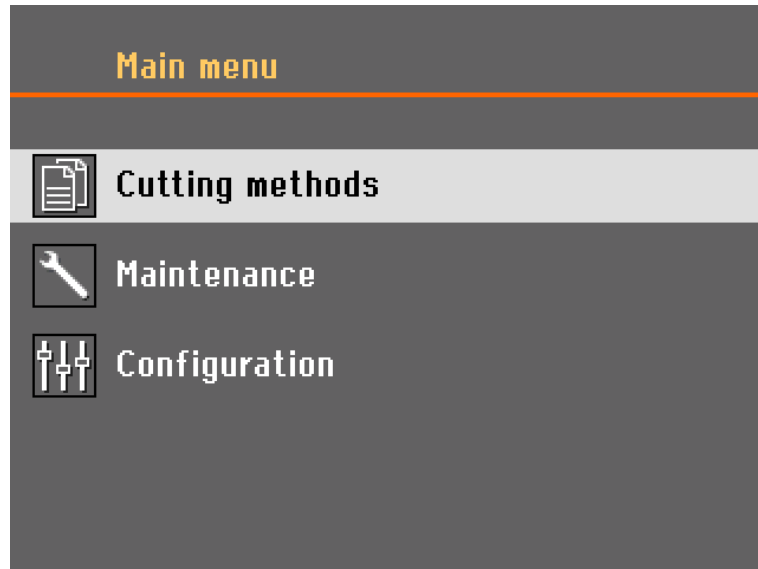

Cutting methods

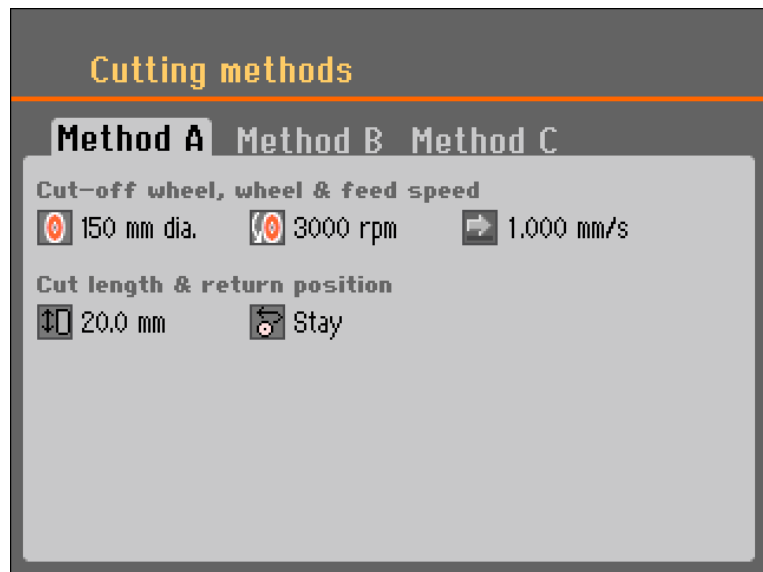



Editing Cutting methods:

 Turn knob to select the cutting method to be edited, *Method A* in this example.

 Push knob to edit the method.



 Turn knob to select the parameter to be edited e.g. *Cut-off wheel*.

 Push knob to edit the parameter then select a cut-off wheel size from the menu.



Recommended rotation speed (rpm) for the cut-off wheels will also be visible in the cutting menu.

Changes made to the cutting method will automatically be saved. To re-set to default values, see the section on [Maintenance](#).

Return position

There are three available options for the position the cut-off wheel will return to after the cutting process is complete:

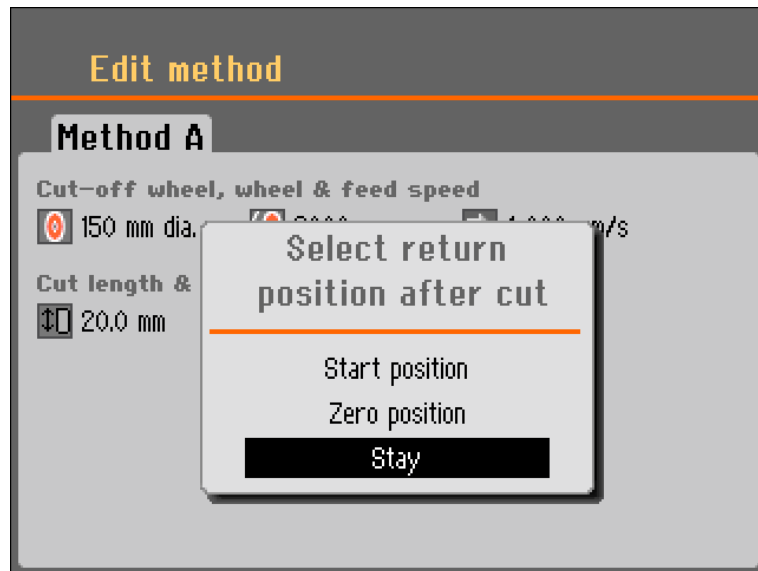

- Start position: Cutting table returns to the start position.
- Zero position: Cutting table returns to zero position.
- Stay: Cutting table does not move after cutting.

OptiFeed

If the motor becomes overloaded during cutting (motor load >150%), the OptiFeed function will automatically reduce the feed speed. When the overload has been reduced, the feed speed will be increased to the pre-set level.

Maintenance

The Maintenance menu has three under menus.

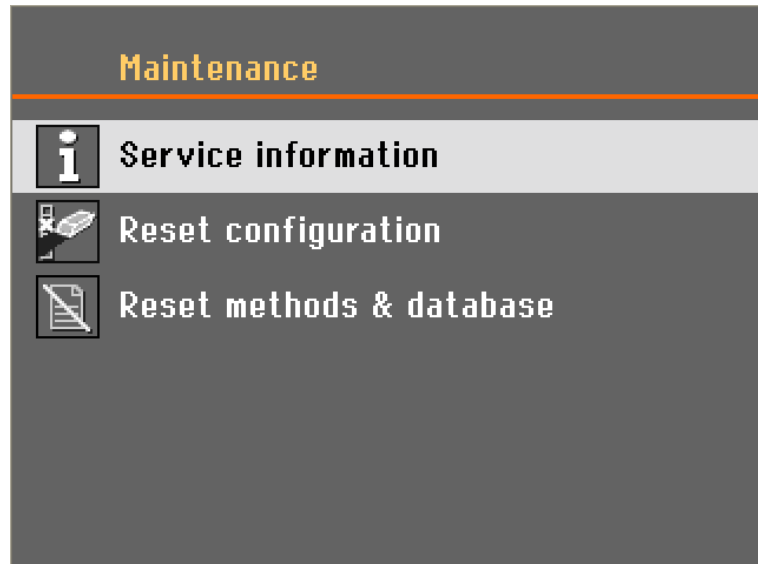

Service information:

Information regarding the equipment, mainly to be used in connection with service.

Reset configuration:

Resets all parameters in the *Configuration menu* to default values.

Reset methods & database:

Resets all methods and the database to default values.

Configuration

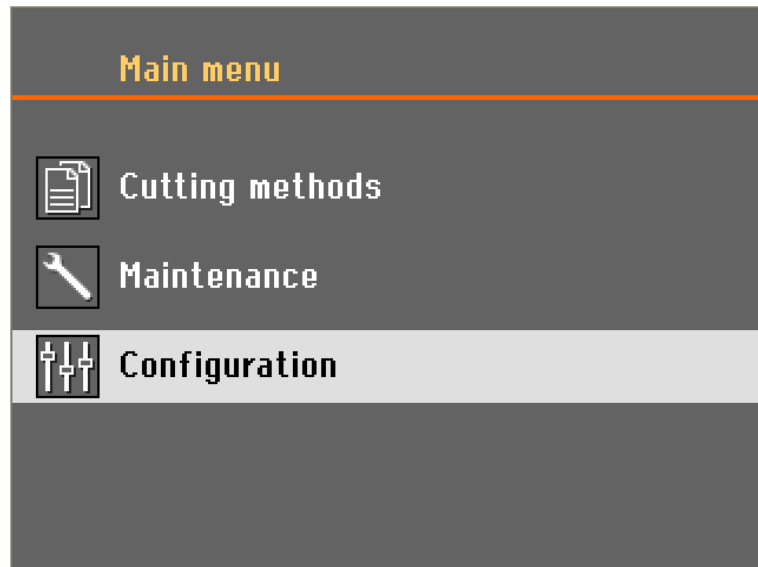

The *Configuration* menu contains the parameters which apply to all methods.

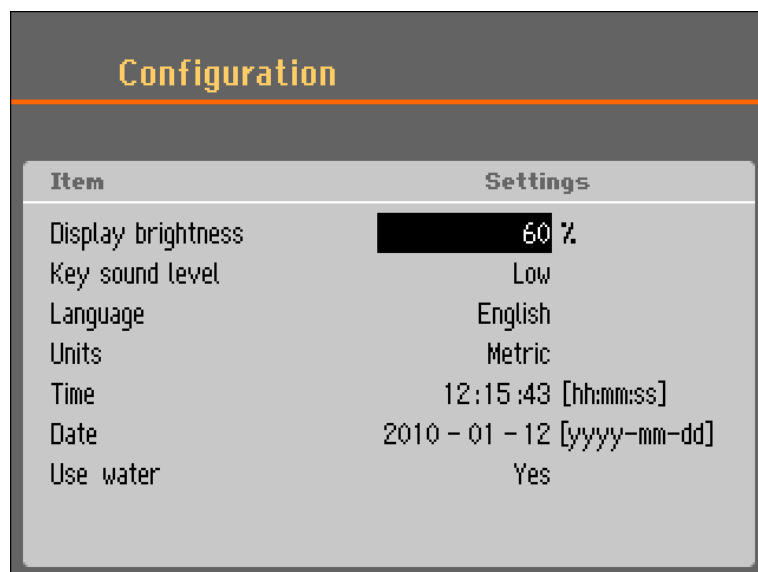

Manual X-stand, accessory



When the manual X-stand is connected a read out for the x-position will appear on the display.

X-position can be reset for easy cutting of a specific width.



Rotary stand, accessory

When the rotary stand is connected a read out for the chuck mode and the x-position will appear on the display.

X-position can be reset for easy cutting of a specific width.



There are three options available in chuck mode:

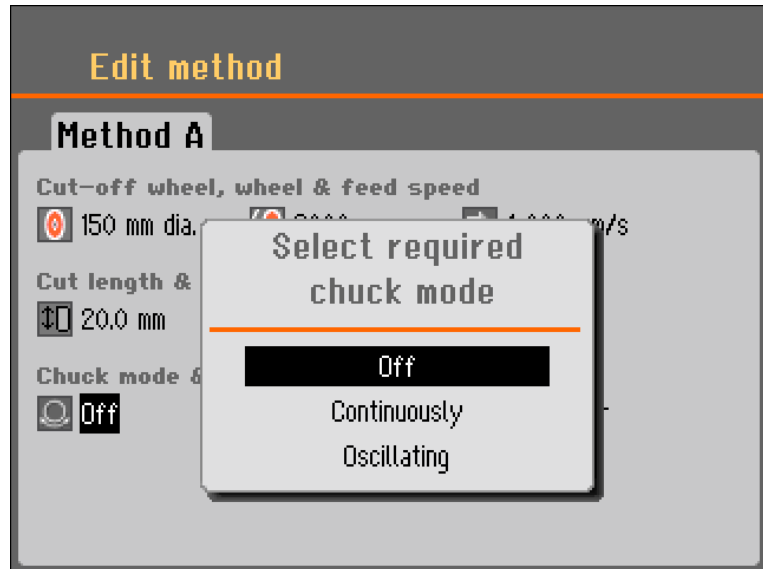

- Off: The specimen holder will not turn.
(Note: Chuck mode must be set to Off before ExciCut can be selected)
- Continuously: The specimen holder will turn round continuously in the same direction as the cut-off wheel.
- Oscillating: The specimen holder will oscillate during the cutting process. X-position can be reset for easy cutting of a specific width.

Starting the Cutting Process

- Secure the work piece on the cutting table.
- Position the cutting table in the correct place.
- Ensure that the cooling fluid nozzles are lowered into position.
- Lower the cover (the machine cannot be started before the cover is down).

Note

The cover cannot be lifted whilst cutting is in progress.

- Using the software display, enter the CUTTING menu and set/check the correct values.
- Start the cutting process by pressing the START  button. If required, Feed speed, Rotation speed and Cutting length can be changed during the cutting process.

NB!

Check that there is a steady flow of cooling fluid from the nozzles.

Stopping the Cutting Process

- When the specified cut length is reached, the cut-off wheel will automatically stop rotating and the cutting table will return to its zero position.

IMPORTANT

The cutting process can be stopped at any time by pressing the STOP button  on the Control Panel.

- If the machine has been stopped with the STOP  key, the cutting table will stay in position. To return the cutting table to its zero position, press the joystick downwards once. Please note that the cover has to be closed in order to carry out this operation. If the cover has been opened, press and hold the joystick down to move the cutting table.

3. Routine Maintenance

Daily Service

- Clean the cutting chamber, especially the cutting table and the T-slots.
To ensure a longer lifetime for your Secotom, Struers strongly recommends daily cleaning of the cutting chamber:

Weekly Service

- Clean the cutting chamber thoroughly.
Oil the spindle/bushing where the cut-off wheel is mounted (e.g. with universal household oil).

Checking the Recirculation Cooling Unit

- Check the level of the cooling water after 8 hours use or at least every week. Refill if necessary.
Replace the cooling fluid if it appears dirty (build up of cutting debris).
Remember to add Struers additive, Corrozip.
To check the concentration of additive, use a refractometer.
Please see the instructions for use on the label.

It is recommended to change the cooling water at least once a month to prevent the growth of microorganisms.

Cooling Fluid Nozzles

- Should the cooling fluid nozzles become blocked, clear the blockage with a thin piece of wire (e.g. a paper clip).

Yearly Service

Inspection of Cover

Visually inspect the cover and the glass for signs of wear or damage.

Important

Carry out inspection at more regular intervals if Secotom- is used for more than one 7 hour shift a day.

Struers recommends that the cover is replaced after 5 years of routine operation.

The cover should be replaced immediately if it has been weakened by collision with projectile objects or if there are visible signs of deterioration as a result of using a cooling fluid other than those produced by Struers.

Cut-off Wheels

Abrasive Cut-off Wheels

Store the dry cut-off wheels in a horizontal position on a plane surface, preferably under light pressure.

Diamond and CBN Cut-off Wheels

A clean and dry cut-off wheel does not corrode. Therefore clean and dry the cut-off wheel before it is put away. Use ordinary household detergents.

Dressing Cut-off Wheels

A newly dressed cut-off wheel will give an optimum cut. A badly maintained and dressed cut-off wheel demands a higher cutting pressure that will result in more frictional heat. The wheel may also bend and cause a skew cut. A combination of both factors may result in damage to the cut-off wheel.

It is a fact that a badly dressed cut-off wheel is the most frequent reason for damage to the wheel.

To dress the cut-off wheel, use the aluminium oxide dressing stick supplied with the cut-off wheel.

- Mount the dressing stick like a workpiece. Do not dress manually.
- Cut through the dressing stick using a moderate cutting pressure and plenty of cooling fluid.
- Repeat the treatment if the cut-off wheel does not cut satisfactorily.

NB Do not perform more dressing than necessary as this will cause needless wear on the wheel.

Reference Guide

Table of Contents	Page
1. Accessories	35
2. Consumables	35
3. Trouble-Shooting	36
4. Maintenance	
Service Information	43
Turning or Replacing Steel Bands on the Cutting Table	43
Changing Cooling Pump Tubes	44
Tube for Water-free Cooling Fluid.....	46
5. Technical Data	47

1. Accessories

Please refer to the [Secotom-15/-50 Brochure](#) for details of the range available.

2. Consumables

The use of Struers consumables is recommended. Other products (e.g. coolants) may contain aggressive solvents, which dissolve e.g. rubber seals. The warranty may not cover damaged machine parts (e.g. seals and tubes), where the damage can be directly related to the use of non-Struers consumables.

Cut-off Wheels

Please refer to the Selection Guide in the [Struers Cut-off Wheels brochure](#).

Other consumables

Specification	Cat. No.
<p><i>Corrozip</i> Additive for Cooling Fluid. To protect the machine from corrosion and to improve cutting and cooling qualities. For Recirculation Cooling Unit.</p> <p>1 l 5 l</p>	<p>449900045 449900046</p>
<p><i>Corrozip-Cu</i> Additive for Cooling Fluid. To protect the machine from corrosion and to improve cutting and cooling qualities. For Recirculation Cooling Unit. For machines which mainly cut copper and copper alloys.</p> <p>1 l 5 l</p>	<p>49900058 49900059</p>
<p><i>Water free Cutting Fluid</i> Water free Cutting Fluid for cutting of water-sensitive materials.</p> <p>5 l</p>	<p>49900030</p>
<p><i>Tube for Water-free Cutting</i> Pump tube for use with Water-free Cutting Fluid.</p> <p>1 pc</p>	<p>05996921</p>
<p><i>Dressing stick</i> Aluminium oxide stick, 1 pc</p>	<p>40800044</p>

3. Trouble-Shooting

No.	Message	Explanation	Action Required
#8	Selected cut length exceeds available cutting capacity. OK: Automatic cut length will be set. Cancel: Go back to edit method.	Insufficient cutting capacity for set length.	Select <i>OK</i> to set cut length automatically, or <i>Cancel</i> to edit method.
#106	Machine failed during Power-On Self Testing. Please try to restart the machine. If problem persists please contact Struers technical support.	A critical error is detected during Power-On Self Testing. The machine will not start.	Re-start. If error remains, contact a Struers Service Technician.
#110	Machine found a problem during Power On Self Testing. Machine can continue, however it is strongly recommended to contact Struers technical support. Some features may not be available.	A critical error is detected during Power-On Self Testing.	Re-start. If the error remains, contact a Struers Service Technician.
#113	Water pump blocked!		Check the cooling fluid level. If the level is low, refill the cooling unit with cooling fluid. Replace the cooling fluid if it appears dirty (build up of cutting debris). If this does not help, contact a Struers Service Technician.
#114	Machine searching for reference positions. Please wait... Don't switch machine off!	Zero positions are calibrated after each 5th startup, or if reference position has been lost or if Emergency Stop has been activated under startup.	Wait until the process is completed.
#117	Water pump blocked! Process halted! Clean cooling system before continuing.		Check the cooling fluid level. If the level is low, refill the cooling unit with cooling fluid. Replace the cooling fluid if it appears dirty (build up of cutting debris). If this does not help, contact a Struers Service Technician.

Secotom-15
Instruction Manual

No.	Message	Explanation	Action Required
#119	Main motor overload detected! Reduce feed speed before continuing.	The cut-off wheel may be caught in the workpiece.	Move the cutting table backwards to release the cut-off wheel, reduce the feed speed and continue cutting.
		The OptiFeed feature is unable to decrease the main motor load to an acceptable level.	Manually reduce the feed speed and continue cutting.
#125	Main motor overheated! Cutting process halted! Please wait until motor temperature decreases before continuing cutting.	The temperature of the main motor has been over 150°C for more than 5sec.	Wait for the motor to cool.
#126	Main motor cannot start. Process halted! Please try to restart the machine if problem occurs after next start.		Switch Secotom off and then on. If this does not help, contact a Struers Service Technician.
#127	Main motor rotation lost. Process halted! Try to restart cutting process. Alarm register: xxxx Error register: xxxx	The cutting process has been aborted.	Make a note of the Alarm register and Error register values then restart the Cutting process. If this does not help, contact a Struers Service Technician and quote the Alarm and Error register values.
#128	Open safety lock detected. Process halted! Restart the process - do not open cover during operation!	Sensors register that the safety lock is open during cutting.	Check that the cover is closed and the safety lock engaged. If this does not help, contact a Struers Service Technician.
#129	Searching of reference positions aborted by user. Machine cannot continue without reference positions found. ↔ Please restart the machine and wait until reference positions are scanned.	Emergency stop has been activated whilst Secotom has been scanning for zero-positions.	Restart the machine and wait until the scan for zero-positions is complete.
#130	Motor drive overloaded! Process halted! Please decrease RPM and/or feed speed before continuing cutting.	The load on the motor has caused an overload.	Decrease the RPM and/or feed speed before continuing cutting
#134	Main motor cannot reach full speed. Process halted! The cut-off wheel is probably touching the workpiece.	Cut-off wheel not able to reach required RPMs within 12 sec. A probable cause is that the cut-off wheel is already in the workpiece.	Re-position the cut-off wheel or workpiece.

Secotom-15
Instruction Manual

No.	Message	Explanation	Action Required
Errors			
#001	SMM not present!	Struers Memory Module isn't correctly connected to machine.	Re-start. If error remains, contact a Struers Service Technician.
#002	Inverter communication failed!	Machine isn't able to communicate with frequency inverter.	Re-start. If error remains, contact a Struers Service Technician.
#003	Joystick not connected!	Machine didn't detect joystick.	Re-start. If error remains, contact a Struers Service Technician.
#004	Mains voltage too low!	Mains voltage lower than 220V.	Check that the mains voltage corresponds to the voltage stated on the type plate on the rear of the machine. Re-start. If error remains, contact a Struers Service Technician.
#005	Problem with 24V supply voltage	DC supply voltage lower than 18V.	Re-start. If error remains, contact a Struers Service Technician.
#006	5V supplying out of range	5V power supply on PCB is lower than 4V	Re-start. If error remains, contact a Struers Service Technician.
#007	SMM read-write test failed	Communication with Struers Memory Module unsuccessful	Re-start. If error remains, contact a Struers Service Technician.
#008	Y-table motor not connected	Communication with the Y-table Stepper Motor Unit failed.	Re-start. If error remains, contact a Struers Service Technician.
#009	CAN bus critical error	Error is caused either by damage on main board CAN controller or due to wrong wiring.	Contact a Struers Service Technician.

No.	Message	Explanation	Action Required
Warnings			
#001	Mains voltage too low	Mains voltage is lower than 180V.	Check that the mains voltage corresponds to the voltage stated on the type plate on the rear of the machine. Re-start. If error remains, contact a Struers Service Technician.

Secotom-15
Instruction Manual

Error	Explanation	Action
Machine Problems		
No, or insufficient cooling fluid.	Level in the cooling fluid tank too low.	Check that there is sufficient water in the Cooling fluid tank.
	Cooling fluid nozzles blocked.	Clean the nozzles.
Water leaking.	Leak in the Cooling fluid tube.	Check the Cooling Pump Tube. Replace if necessary.
	Water overflow in the cooling fluid tank.	Remove the excess water.
	The basket for cutting debris is blocked.	Clean the basket.
Workpieces rusty.	Insufficient additive in cooling fluid.	Check the concentration of Corrozip in the cooling fluid. Follow the instructions in the ' Routine Maintenance ' Section.
Cutting chamber rusty.	Insufficient additive in cooling fluid.	Check the concentration of Corrozip in the cooling fluid. Follow the instructions in the ' Routine Maintenance ' Section.
	The lid is left closed after use.	Leave the lid open to let the cutting chamber dry.
Cutting chamber shows signs of corrosion.	The workpiece is made of Copper/ Copper Alloy.	Use Corrozip-Cu.

Secotom-15
Instruction Manual

Error	Explanation	Action
Cutting Problems		
Discoloration or burning of the workpiece.	The hardness of the cut-off wheel is inappropriate for the hardness / dimensions of the workpiece.	Select another wheel. Please refer to the Brochures for details of the range available. Alternatively, reduce rotational speed.
	Inadequate cooling.	Check the positioning of the cooling fluid nozzles. If necessary, clean the nozzles.
		Check that there is sufficient water in the Cooling fluid tank. Check the concentration of Corrozip in the cooling fluid.
Unwanted burrs.	Cut-off wheel too hard.	Select another wheel. Please refer to the Brochures for details of the range available. Alternatively, reduce rotational speed
	Feed speed too high at the end of the operation.	Reduce the feed speed near the end of the operation.
	Incorrect clamping of the workpiece.	Support the workpiece and clamp it on both sides. e.g. Struers' Specimen Holder CATAL, which is designed for clamping small, long workpieces on both sides..
Cutting quality differs.	Inadequate cooling.	Check the positioning of the cooling fluid nozzles. If necessary, clean the nozzles
		Check that there is sufficient water in the Cooling fluid tank.
		Check the concentration of Corrozip in the cooling fluid.

Secotom-15
Instruction Manual

Error	Explanation	Action
Cut-off wheel breaks.	Incorrect mounting of the cut-off wheel.	Check that the bore/centre hole has the correct diameter. The nut must be tightened properly.
	Incorrect clamping of the workpiece.	Support the workpiece and clamp it on both sides. e.g. Struers' Specimen Holder CATAL, which is designed for clamping small, long workpieces on both sides..
	Cut-off wheel is too hard.	Select another wheel. Please refer to the Brochures for details of the range available. Alternatively, reduce rotational speed.
	Feed speed is set too high.	Reduce the feed speed.
	Force level is set too high.	Reduce the Force level.
	Cut-off wheel bends on contact with the workpiece.	Make an initial cut at a lower feed speed.
The cut-off wheel wears down too quickly.	The feed speed is too high.	Reduce feed speed.
	The rotational speed is too low.	Increase rotational speed.
	Insufficient cooling.	Check that there is enough water in the Cooling fluid tank. Check the positioning of the cooling fluid nozzles. If necessary, clean the nozzles
The cut-off wheel does not cut through the workpiece.	The rotational speed is too low.	Increase rotational speed.
	Incorrect choice of cut-off wheel.	Please refer to the Brochures for details of the range available.
	Cut-off wheel worn.	Replace the cut-off wheel.
The workpiece breaks when clamped.	The cut-off wheel gets caught in the workpiece during cutting.	Clamp the workpiece on both sides of the cut-off wheel so that the cut stays open. e.g. Struers' Specimen Holder CATAL, which is designed for clamping small, long workpieces on both sides.
	The workpiece is brittle.	Place the workpiece between two plastic/rubber plates. Alternatively, mount the workpiece in resin. Note! Always cut brittle workpieces very carefully.

Secotom-15
Instruction Manual

Error	Explanation	Action
The specimen is corroded	The specimen has been left in the cutting chamber for too long.	Remove the specimen directly after cutting. Leave the cutting chamber hood open when you leave the machine.
	Insufficient additive for cooling fluid.	Check the concentration of Corrozip in the cooling fluid.

4. Maintenance

Service Information

Struers recommends that a regular service check be carried out after every 1500 hours of use. Information on total operation time is displayed on the screen at start-up:

A reminder will appear after 1400 hours operation time to remind the user that a service check should be scheduled.

After the 1500 hours operation time has been exceeded the Service-Info will change to alert the user that the recommended service interval has been exceeded: "Service period expired!"

- Contact a Struers service technician to service the machine.

Turning or Replacing Steel Bands on the Cutting Table

During normal use, it is not uncommon for the cutting table steel bands located on either side of the cutting area to be damaged. If the bands are only damaged on one side, then they can be turned. If they are very badly damaged or damaged on both sides, replace the bands (available as a Spare Part).

Changing Cooling Pump Tubes

To exchange the tube:

- Remove the four screws on the protection plate on the rear of the machine.

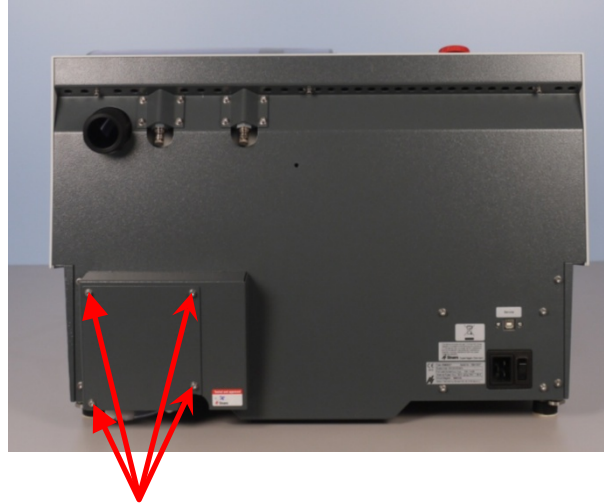

- Remove the three screws on the cover on the cooling pump.

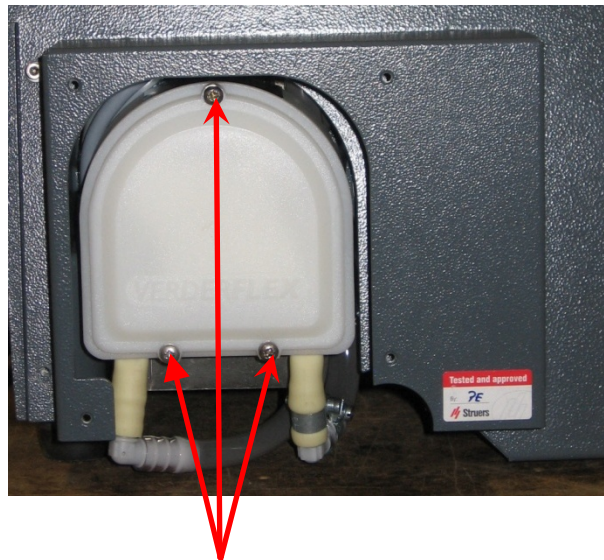

- Remove the tube from the pump axle.

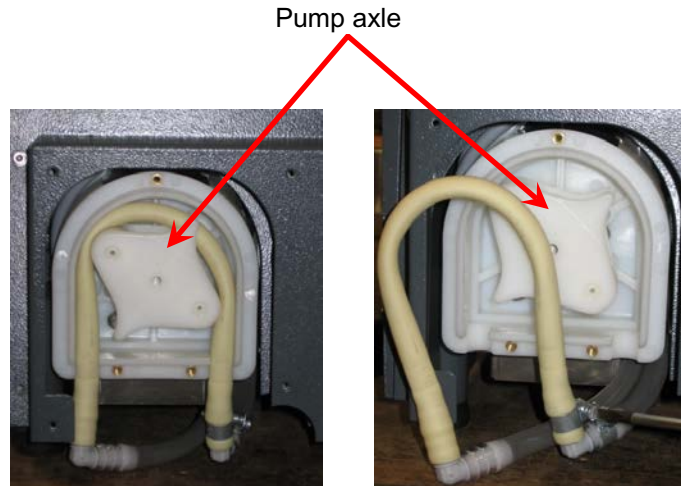

- Loosen the hose clamp and carefully remove the tube ends from the connectors.
- Attach the new tube to the connectors and tighten the hose clamp (the hose clamp should be on the end of the tube that directs water/cooling fluid into the cutting chamber, as this will have the greatest pressure – see picture).
- Lubricate the tube along its length with the silicon grease enclosed (this will help the rollers in the pump to turn smoothly).
- Press the tube into position around the pump axle.

- Mount the tube correctly in the pump:

Correct:

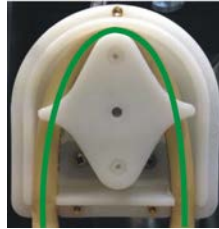

Incorrect:

Too loose

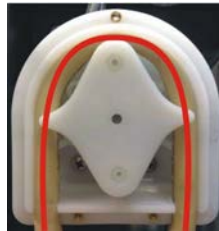

Excess volume between the rollers will press "waves" of fluid which will stretch the tube; lifetime of the tube will be reduced.

Too tight

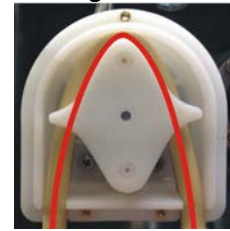

The tube is stretched; lifetime of the tube will be reduced.

- Replace the pump cover and the protection plate.

Tube for Water-free Cooling Fluid When working with Water-free Cutting Fluid, the standard tube mounted in the cooling fluid pump will only last for a few days. A special tube, which is resistant to the components of the Water-free Cutting Fluid, is available as a Spare Part.

5. Technical Data

Subject		Specifications	
Cutting	Motor	0.8 kW	
	Voltage/frequency 1 x 220 – 240 V / 50 - 60 Hz	Max. load 11.7 A	
	Cutting Power S1 S3	0.8 kW 1.0 kW	
	Cut-off wheels	75 mm (3") - 203 mm (8") dia.	
	Output axle Rotational speed: Diameter:	300 - 5,000 rpm (in steps of 100 rpm) 12. 7 / 22 mm (0.5 / 0.86")	
Positioning & Feed	Positioning range (of cut-off wheel)	0 – 40 mm (0 – 1.6")	
	Positioning range (of cutting table)	0 – 190 mm (0 – 7.5") (in steps of 0.1mm)	
	Max. positioning speed of table	20 mm/s / 0.79"/s	
	Feed Speed range of table	0.005 – 3.000 mm/s (0.2 – 120 Mil/s) (in steps of 0.005 mm/s / 0.2 Mil/s)	
Dimensions		Height: 440 mm / 17.3" cover closed 1055 mm / 41.5" cover open Width: 640 mm / 25.2" Depth: 700 mm / 27,6" (with plug) Weight: 68 kg / 150 lb	
Cutting Table dimensions	Width	258 mm	10.2"
	Depth	184 mm	7.24"
	T-slots	8 mm	0.31"
Cutting Capacity		70 mm dia. or 165 x 50 mm 2.8" or 6.5 x 2"	
Recirculation Cooling Unit	Capacity:	4.75 l / 1.25 gallon	
	Flow:	1.6 l/min / 0.4 gallon/min	
Safety Standards	Please refer to the Declaration of Conformity		
Noise Level	Approx. 60 dB (A) measured at idle running, at a distance of 1.0 m / 39" from the machine.		
Operating environment	Surrounding temperature	5-40°C/41-104°F	
	Humidity	0-95% RH non condensing	

Quick Reference

Mounting the Cut-off Wheel

- Lift the cooling fluid nozzles.
- Insert the stop pin into the hole of the inner flange.
- Loosen the flange screw.
- Remove the outer flange.
- Mount the cut-off wheel and remount the outer flange, with the machined face towards the inner flange.
- Insert the locking pin in the hole in the inner flange. Gently fasten the flange screw.
- Lower the cooling fluid nozzles to their operating positions.

IMPORTANT

When mounting cut-off wheels with a 12.7 mm centre hole, make sure that the 22 mm arbour insert has been removed. Failure to do this will result in the cut-off wheel being pressed out of shape.

Clamping the Workpiece

Clamping device:

- Secure the back stop at the rear of the cutting table.
- Secure the clamping device in front of the back stop.
- Place the workpiece between the clamping device and the back stop so it is firmly fixed. If necessary, move the clamping device for optimal fixation.

Using stands:

- Place the stand on the cutting table and secure the bolts. Connect the electrical connections (if required).
- Clamp the workpiece in a suitable specimen holder.
- Mount the specimen holder with the workpiece in the stand and secure.

Adjusting the Height of the Cut-off Wheel

- Use the adjusting wheel on the left hand side of Secotom to raise and lower the cut-off wheel.

Positioning the Cutting Table

- Move the joystick up- or downwards to position the cutting table.

**Starting the
Cutting Process**

- Close the cover.
- Choose a cutting method and set/check the cutting parameters. Use the Turn/Push knob to select and change the values.
- Start the cutting process by pressing the START  button.

**Stopping the
Cutting Process**

The cutting process stops automatically when the specified cut length is reached.

- To stop the cutting process manually, press the STOP button .

English

Declaration of Conformity

Manufacturer

Struers ApS
 Pederstrupvej 84
 DK-2750 Ballerup, Denmark
 Telephone +45 44 600 800

Herewith declares that

<i>Name:</i>	Secotom-15/-50
<i>Cat. No.:</i>	05996127, 05996227
<i>Function:</i>	Precision cut-off machine
<i>Type No.:</i>	599

fulfils all the relevant provisions of the:
**Machinery Directive
 2006/42/EC**

according to the following standard(s):
 EN ISO 12100:2010, EN 60204-1:2006/AC:2010, EN ISO 14120:2015.

and is in conformity with the:
**EMC Directive
 2014/30/EU**

according to the following standard(s):
 EN 61000-6-2:2005, EN 61000-6-4:2007/A1:2011, EN 61326-1:2013.

**RoHS Directive
 2011/65/EU**

according to the following standard(s):
 EN 50581:2012.

Supplementary Information

The equipment complies with the following standards:
 UL508, NFPA70:2014, NFPA79: 2012, FCC 47 CFR part 15.

The above has been declared according to the global approach, module A.

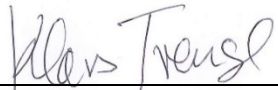
Authorized to compile the Technical File:

Klavs Tvenge
 Director of Business Development
 Struers ApS
 Pederstrupvej 84
 DK-2750 Ballerup, Denmark

Date of Issue: 2017.10.05



Pederstrupvej 84
DK-2750 Ballerup
Denmark

Secotom-15/-50



Spare Parts and Diagrams

Manual No.: 15997001

Date of Release ~~GEF~~ ~~EU~~.
Á



Secotom-15/-50
Spare Parts and Diagrams

**Always state *Serial No* and *Voltage/frequency*
if you have technical questions or when ordering spare parts.**

The following restrictions should be observed, as violation of the restrictions may cause cancellation of Struers legal obligations:

Instruction Manuals: Struers Instruction Manuals may only be used in connection with Struers equipment covered by the Instruction Manual.

Service Manuals: Struers Service Manuals may only be used by a trained technician authorised by Struers. The Service Manual may only be used in connection with Struers equipment covered by the Service Manual.

Struers assumes no responsibility for errors in the manual text/illustrations. The information in this manual is subject to change without notice. The manual may mention accessories or parts not included in the present version of the equipment.

The contents of this manual are the property of Struers. Reproduction of any part of this manual without the written permission of Struers is not allowed.

All rights reserved. © Struers 2016.

Struers

Pederstrupvej 84
DK-2750 Ballerup
Denmark
Telephone +45 44 600 800
Telefax: +45 44 600 801

Spare Parts and Diagrams

Table of contents

Drawing

Secotom-15/-50

Drawings

Secotom-50, complete	15990001C
Base assembly-50.....	15990010W
Back plate assembly	15990011G
Cabinet design-50, complete	15990012J
Front plate-50, assembled	15990013L
Lid assembly	15990016J
Motor console support.....	15990017H
Motor console.....	15990018I
Reservoir, complete	15990019D
Cooling nozzles.....	15990021C
Step motor elevation, complete.....	15990022F
Y-shaft.....	15990024D
Small back plate assembly.....	15990025B
Y-table, assembly.....	15990026E
T-table stepmotor assembly.....	15990027E
Ventilation assembly	15990028D
Blinder complete	15990032F
Pump complete	15990033H
Absorber assembly	15990034G
Damper assembly	15990074C

Diagrams

Block diagram Secotom-15/-50.....	15993050C
Circuit diagram Secotom-15/-50 (3 pages)	15993100F

Some of the drawings may contain position numbers
not used in connection with this manual.

Secotom-15/-50
Spare Parts and Diagrams

The following is a list of the spare parts that may need replacement during the lifetime of the equipment.

To check the availability of other replacement parts, please contact your local Struers Service Technician. It may help identify the part by referral to its position number on the assembly drawings included in this manual.

Spare Part List for Secotom-15/-50

Drawing	Pos.	Spare Part	Cat no.	
15990001		Secotom 50, complete		
	40	Reservoir, complete	15990019	
15990010		Base assembly-50		
	60	MOTOR 3x200-240V/50Hz 1,1kW	2ME30754	
	120	Flange 50, back	15990621	
	240	Tooth.belt HTD 372-3M-9	2JT20372	
	250	Power Supply 85-264V, 24V/6A	2PA90150	
	410	Tooth.belt HTD 318-3M-9	2JT20318	
	420	1500W Inv. OMRON 230V 50/60Hz	2PU32111	
	440	SPULEHOVED	15030510	
	450	HosePVC.transp.ø9/ø13.5 Portex, 65cm	2NU18090	
	460	Sealing strip Grey 2x5 , 0.1m	2IP10202	
	50	Flange screw	15030753	
	610	HosePVC.transp.ø9/ø13.5 Portex, 1.05m	2NU18090	
	630	HosePVC.transp.ø9/ø13.5 Portex, 20cm	2NU18090	
	650	Silicone hose ø8/ø12, 8cm	2NU19208	
	670	O-ring 72 NBR 872. 15.60-2.40, 2pcs	2IO24034	
	690	Sealing strip Grey 2x5, 15cm	2IP10202	
	730	Sucking tube holder	15990127	
	750	Sealing strip Grey 3x9, 0.5m	2IP10301	
	760	Sealing strip Grey 3x9, 0.7m	2IP10301	
	770	Sealing strip Grey 3x9, 6cm	2IP10301	
	780	Sealing strip Grey 3x9, 0.3m	2IP10301	
	820	Dresser blinder	15990416	
	15990012		Cabinet design 50,complete	
		20	Lid assembly	15990016
		90	Cooling nozles	15990021
		130	Sealing strip Grey 2x5, 0.9m	2IP10202
		140	Sealing strip Grey 2x5, 0.45m	2IP10202
180		Frontplate 50, assembled	15990013	
220		CAP for female socket IP68	2XM90005	

Spare Part List for Secotom-15/-50

Drawing	Pos.	Spare Part	Cat no.
15990013		Frontplate 50, assembled	
	50	Display 320x240 TFT-color, LED	2HD50200
	60	PCB Tegramin, Tested+Bootload.	16013000
	90	Frontplate joystick fixation	15990173
	180	Bracket for memory stick	16030174
	190	PCB for SMM, Tested	15483004
	200	Foil, Secotom-50	15990400
	210	Turn/push encoder w.cable, 24p	2HR12412
	220	O-ring 72 NBR 872. 36.00-2.00	2IO20060
	240	Joystick, assembly	15990038
15990019		Reservoir, complete	
	10	Reservoir door, painted	15999251
	20	Reservoir	15990220
	30	Cap for 15030170	72000027
15990021		Cooling nozles	
	10	Plug, Thumb screw, 2pcs	14940429
	20	O-ring 72 NBR 872. 10.82-1.78, 6pcs	2IO17815
	30	Nozzle shaft	15990181
	40	Nozzle hinge, 2pcs	15990183
	50	Nozzle body	15990182
	70	Nozzle tube, 2pcs	15990184
15990026		Y-table, assembly	
	40	Plate, T-slot, 30mm, 7pcs	15030430
		Miscellaneous	
	10	Stop pin, assembl.	14940701
	20	Angle pipe wrench 291. 17mm	2GR00317
	30	Hose Danflex K-126 ø51, 1.5 m	2NU30251
	40	Worm hose clamp 40-60/9.0-C6W2	2NS24060
	50	Mains ca. 1.5mm ² , C19-Schuko	2WC04680
	60	Mains ca. AWG14, C19-Nema 6-15	2WC02530

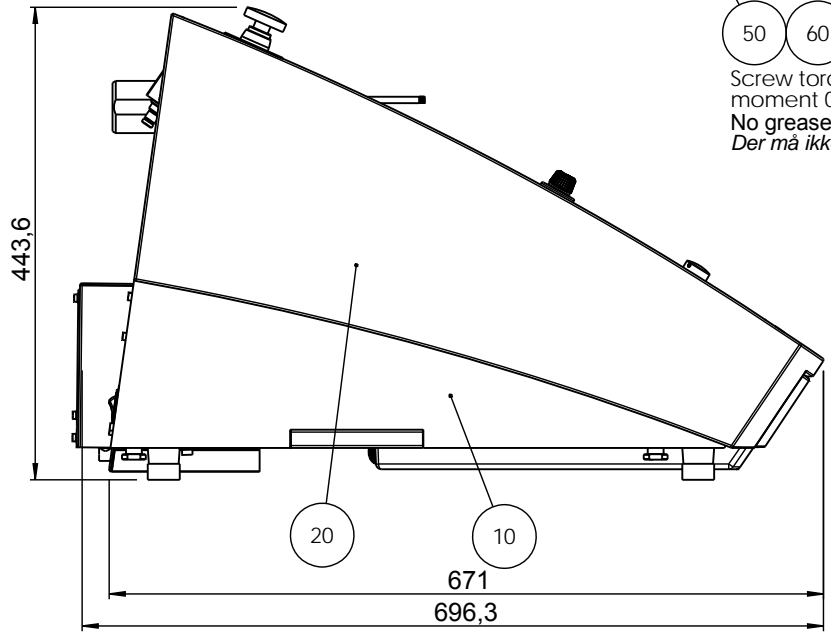
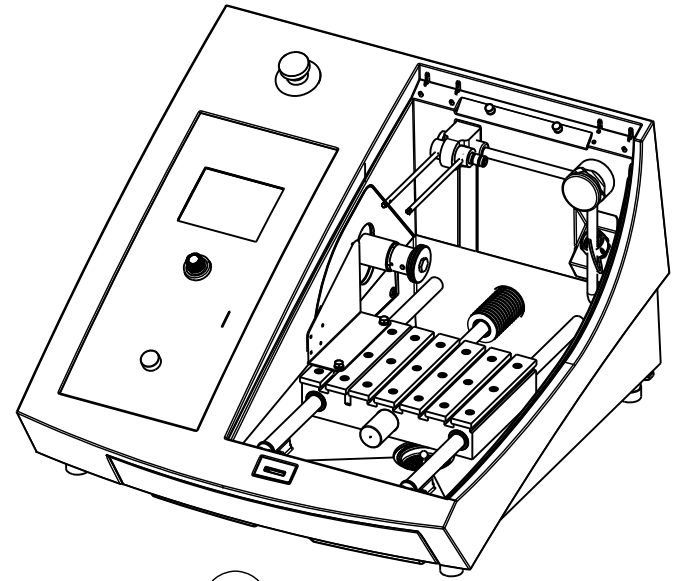
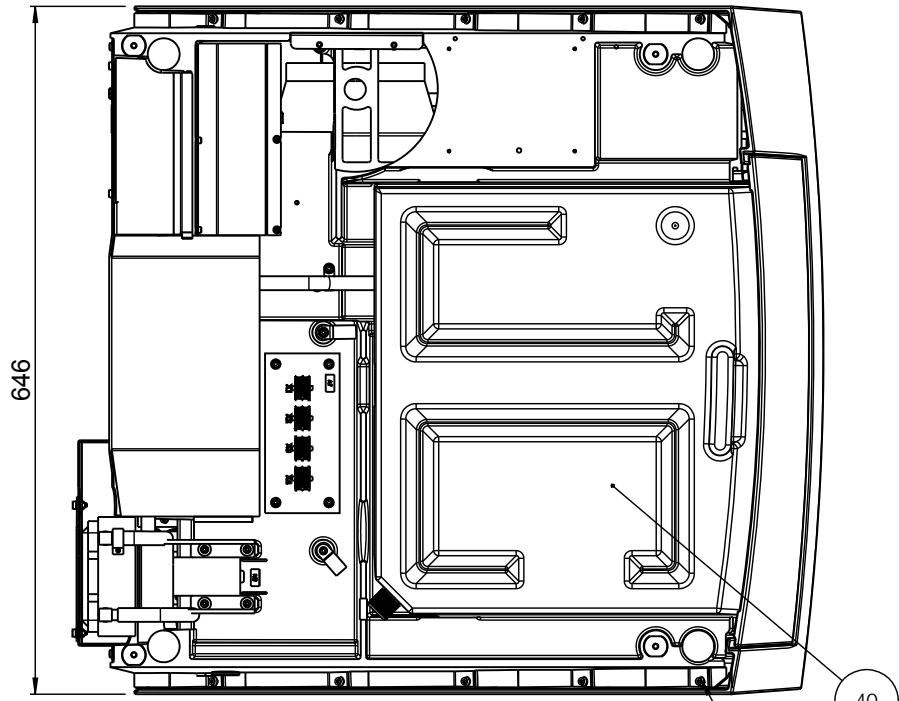

Screw torque moment 0.8Nm
No grease of any kind allowed
Der må ikke bruges smørremidler

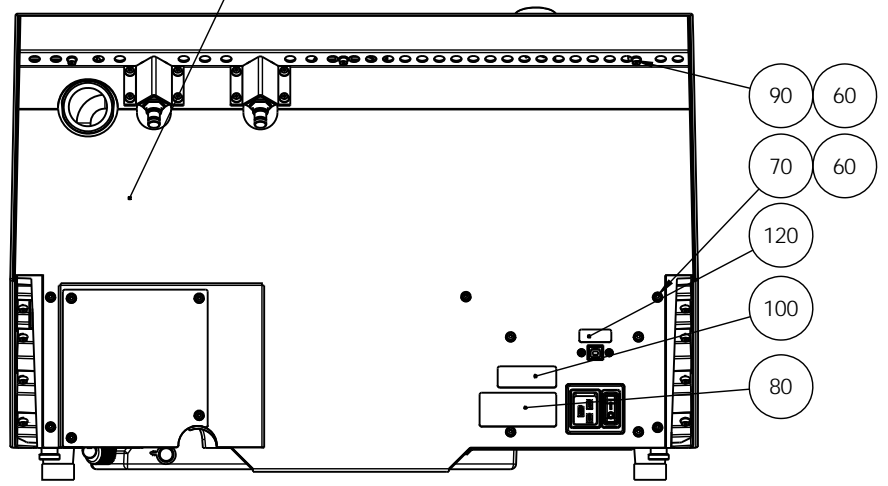

B	2010-11-02	moved label (120), add torque moment (50), replaced (50)	PPL	2010-11-02	AKN
A	2010-05-19		PPL	2010-05-19	AKN
Revision	Crea. date yyyy-mm-dd	Revision description	Draw. Init	Appr. date yyyy-mm-dd	Appr. Init
		Material:	Scale: 1:5	Format: A3	Tolerance: DS/ISO 2768- mK Surface treat.: None
ID:	Description: 15990001 Secotom 50- complet				Rev: B

Pederstrupvej 84
DK-2750 Ballerup/Copenhagen
Denmark
Phone: +45 44 600 800
Fax: +45 44 600 804

SECTION B-B

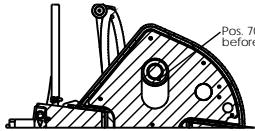

Pos. 70 sealed with transparent silicone before mounting.

Remember that sealing strips pos. 750, 760, 770 and 780 must overlap partially on each other by mounting.

Place the rubber washer under the steel washer

Remove screws, fill 15 ml of 2LS10100 oil to each, put screws back.

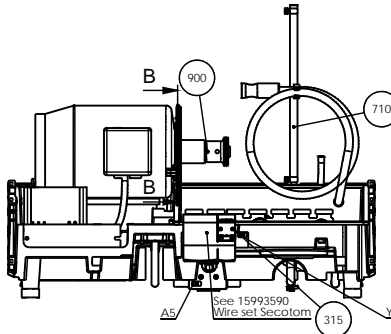
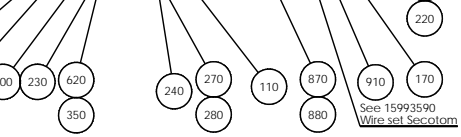
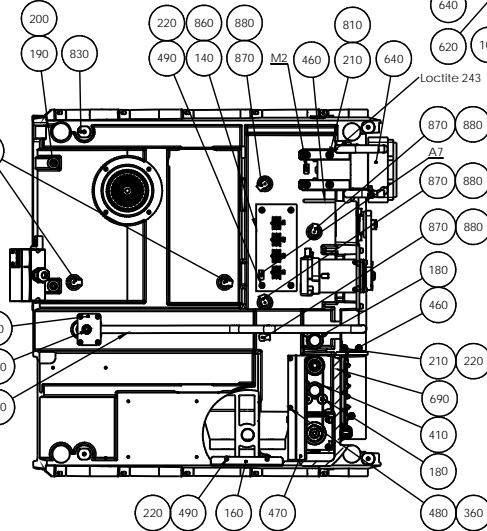
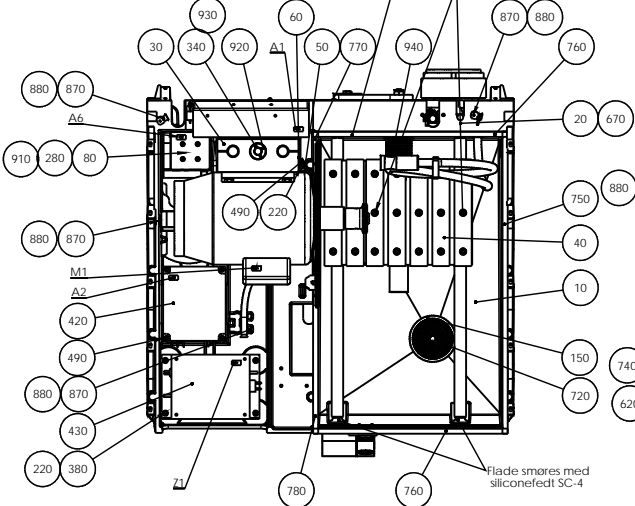
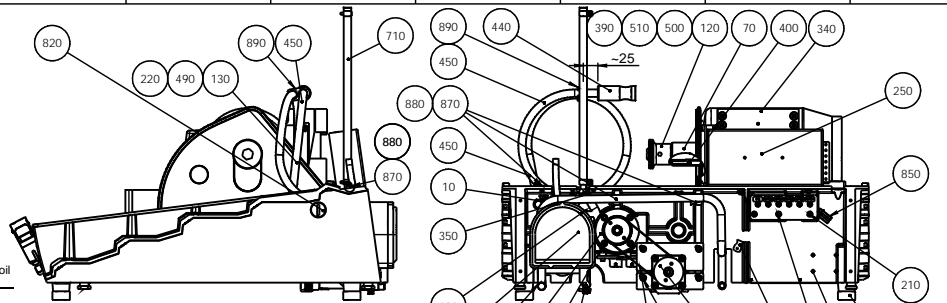

- 860 Place in A7: X2
- 30 40 Grease with 2LS00000 Shell Gadus S2 V220
- To mount 400 use 15991519 Adjusting pin, see PF15997350
- To adjust concentricity 60 and 70 use 15991519 Adjusting pin
- 2LS00002 Shell Gadus S3 V220 to blinder 70 and V-ring 400
- 2LS00002 Shell Gadus S3 V220 between blinder 70 and fork of 130 50
- 440 2LS00300 High Vacuum Grease, inside
- 500 15030753 Flange screw max. tightening torque 5Nm

650 silicone tubing cut into 30 degrees on the end facing the bath

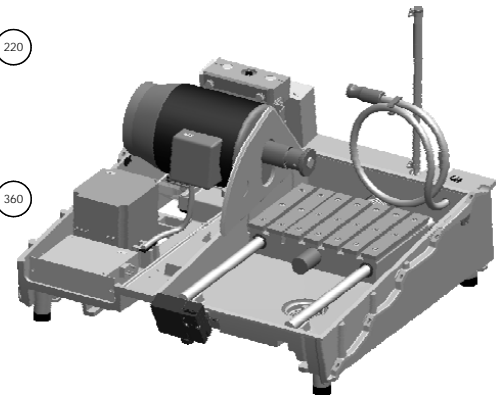

W	2016-08-01	C3: pos. 60 added	OCR	2016-08-01	JTV
A	2010-05-18		PPL	2010-05-18	AKN
Revision	Cre. date	Revision description	Draw. Init	Appr. date	Appr. Init
Material:		Scale:	Format:	Tolerance: DS/ISO 2768:	Surface treat.:
		1:5	A2	mK	None
Description:					Rev:
15990010 Base assembly-50					W

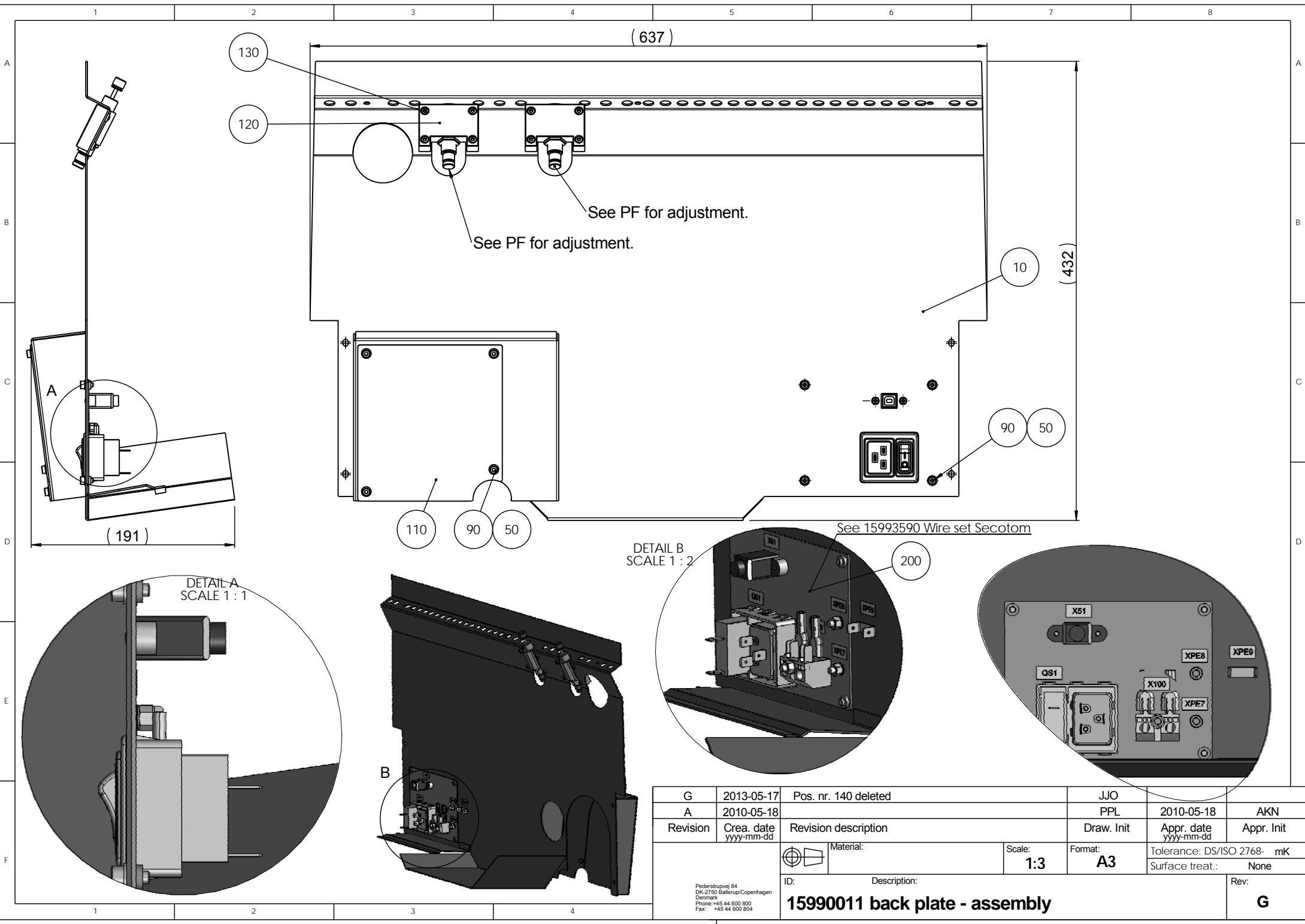

G	2013-05-17	Pos. nr. 140 deleted	JJO		
A	2010-05-18		PPL	2010-05-18	AKN
Revision	Crea. date yyyy-mm-dd	Revision description	Draw. Init	Appr. date yyyy-mm-dd	Appr. Init
		Material:	Scale: 1:3	Format: A3	Tolerance: DS/ISO 2768- mK
		ID:	Description:		Surface treat.: None
		15990011 back plate - assembly			Rev: G

Pederstrupvej 84
DK-2750 Ballerup/Copenhagen
Denmark
Phone: +45 44 600 800
Fax: +45 44 600 804

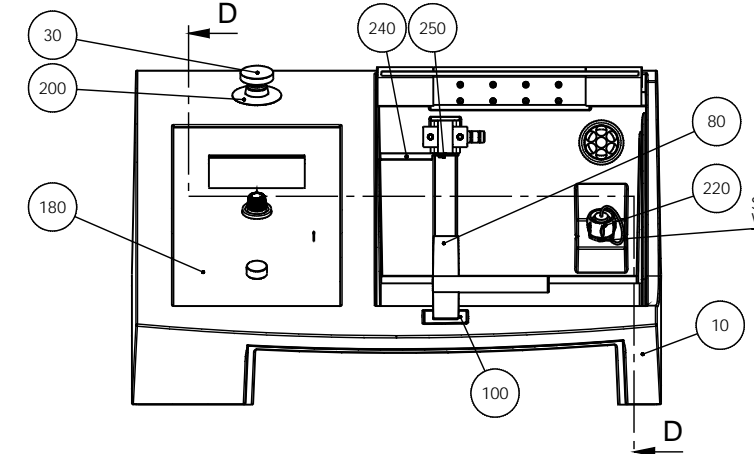
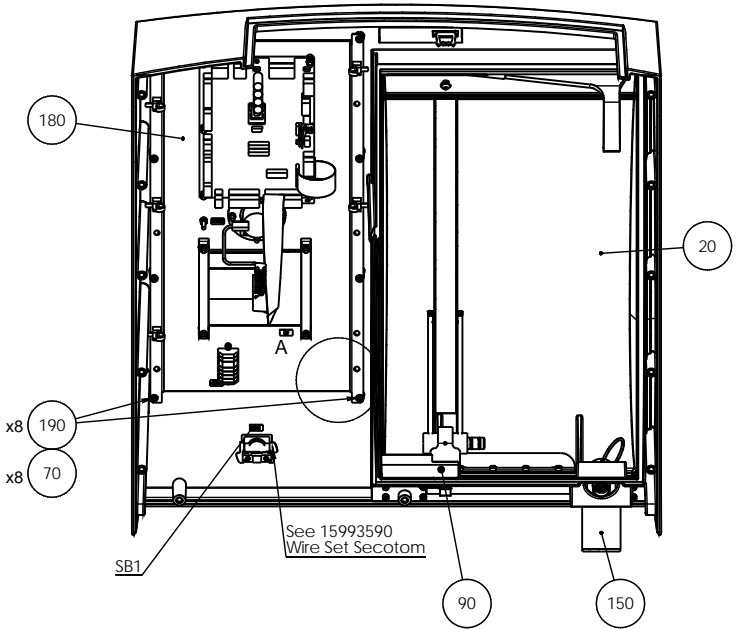

Holes for damper
drilling with drilling jig. 15991527 Drilling tool for cabinet

Huller for dæmper
bores efter lære 15991527 Drilling tool for cabinet

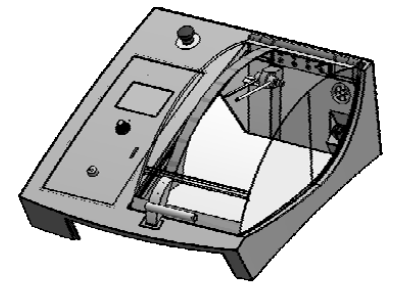
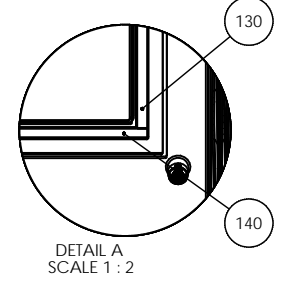
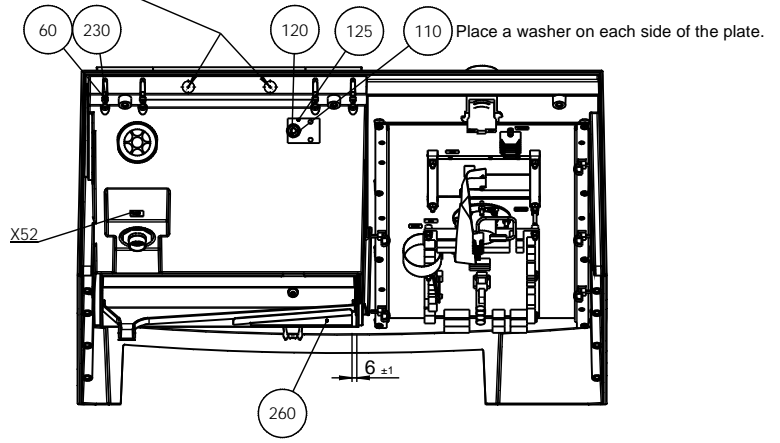

80 100 Glued by 2LL00330 Universal Silicone 512 transp.

J	2015-12-04	C6: Pos 260 added	JTV	2015-12-04	JTV
A	2010-01-18		PPL	2010-01-18	AKN
Revision	Crea. date yyyy-mm-dd	Revision description	Draw. Init	Appr. date yyyy-mm-dd	Appr. Init
		Material:	Scale: 1:5	Format: A3	Tolerance: DS/ISO 2768- mK Surface treat.: None
<small>Federstrøvsvej 84 DK-2700 Ballerup/Copenhagen Denmark Phone: +45 44 600 800 Fax: +45 44 900 804</small>		ID:	Description: 15990012 Cabinet design - complete 50		Rev: J

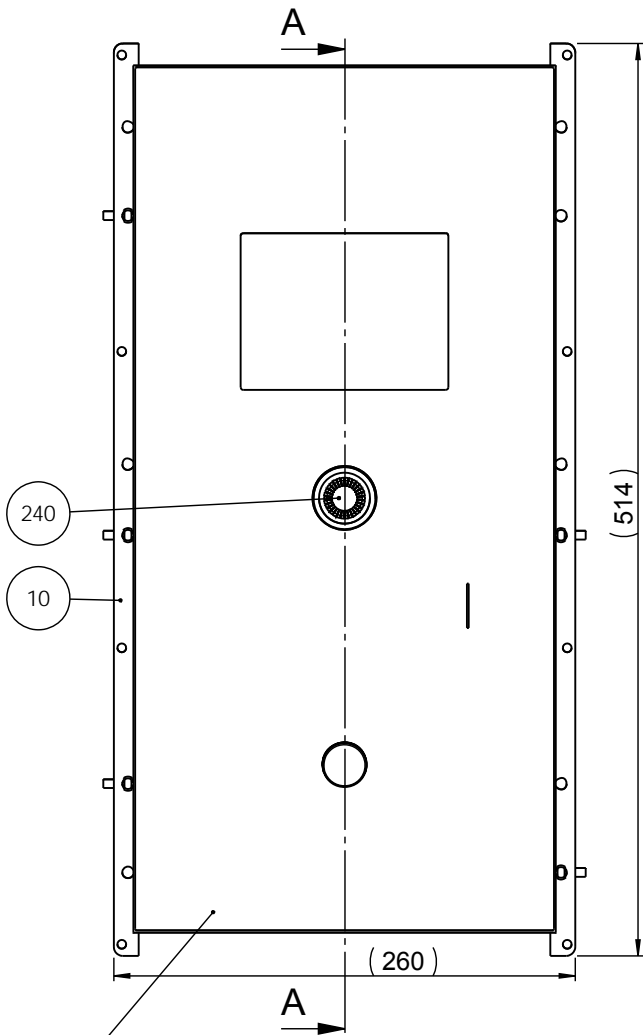

SECTION A-A

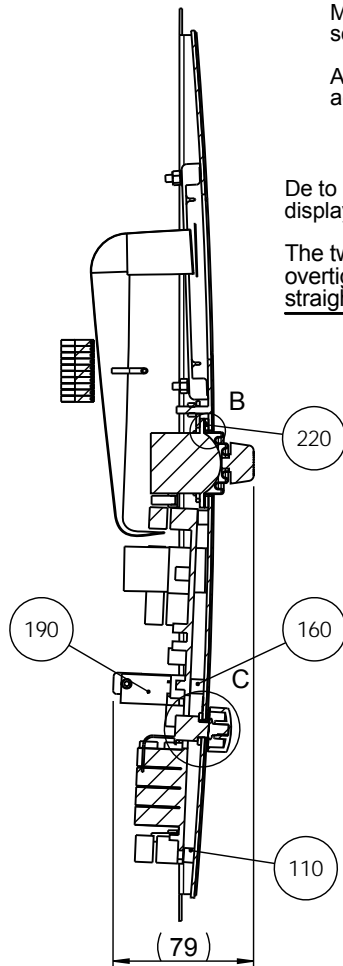

Monter et stykke 2IP94949 tape som aflastning for fladkabel.
Attach a piece 2IP94949 acrylic tape for ribbon cable.

De to beslag må ikke overspændes, displayet skal forblive lige, må ikke bøje.

The two fittings must not be overtightened, display must remain straight, do not bend.

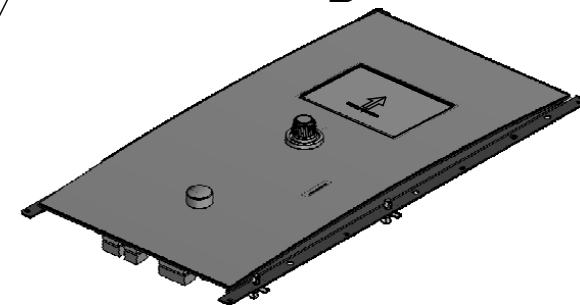
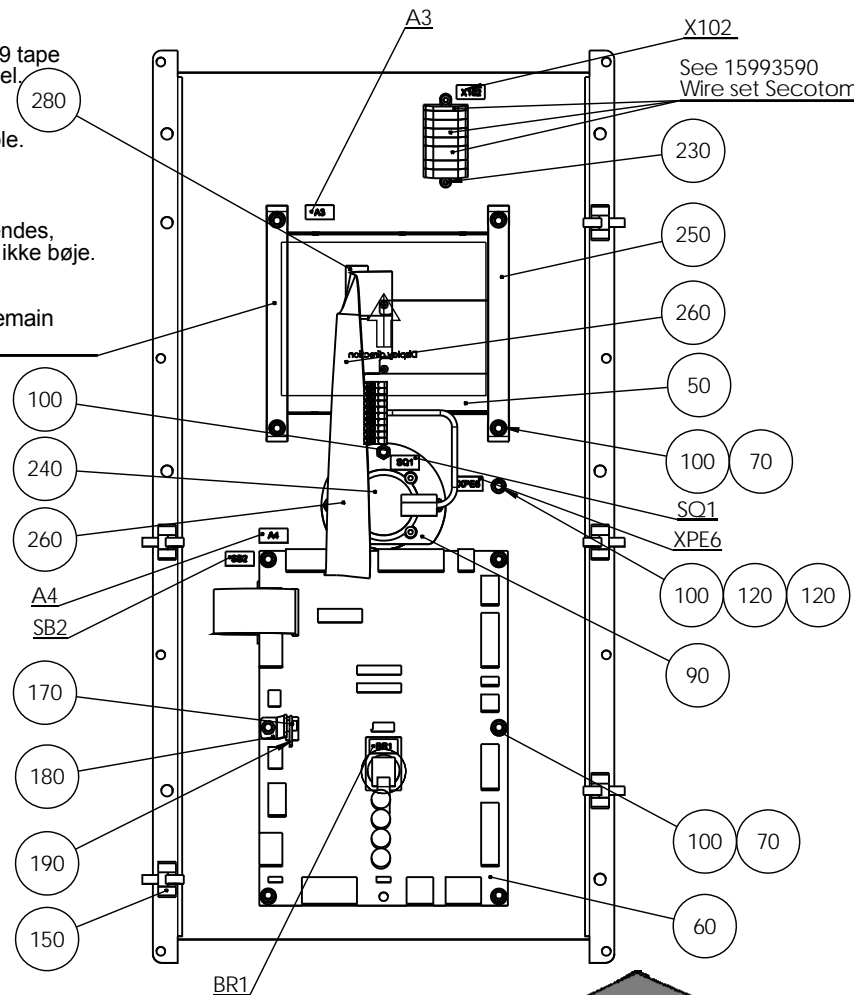

200 Beskyttelses plastik omkring vindue må ikke fjernes.
Protective plastic around the window must not be removed.

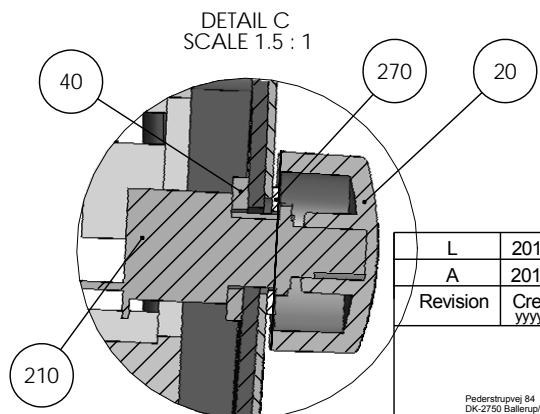
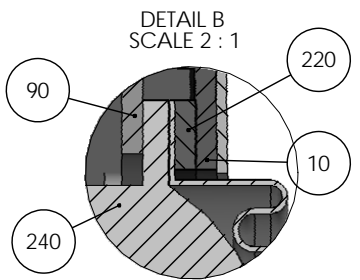

L	2013-06-25	A5 and E1: Text added.	JJO		
A	2010-05-18		PPL	2010-05-18	AKN
Revision	Crea. date yyyy-mm-dd	Revision description	Draw. Init	Appr. date yyyy-mm-dd	Appr. Init
		Material:	Scale: 1:3	Format: A3	Tolerance: DS/ISO 2768- mK
		ID:	Description:		Surface treat.: None
		15990013 Frontplate - assembly-50			Rev: L

Pederstrupvej 84
DK-2750 Ballerup/Copenhagen
Denmark
Phone: +45 44 600 800
Fax: +45 44 600 804

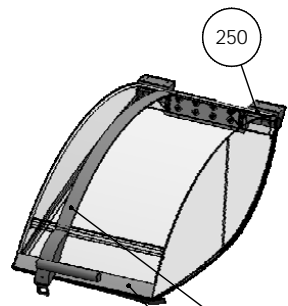

Mounted after 240 og 250

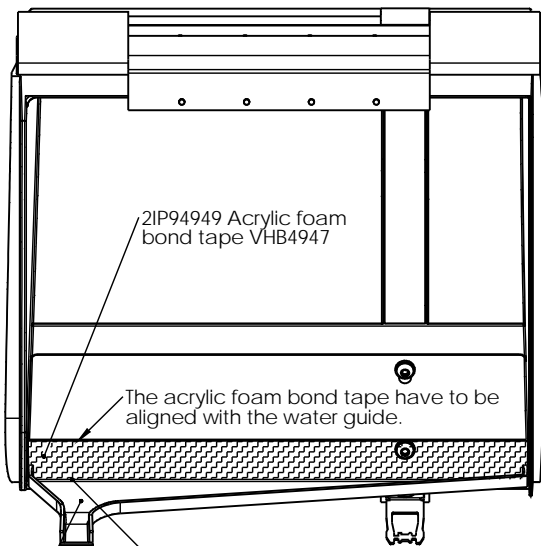
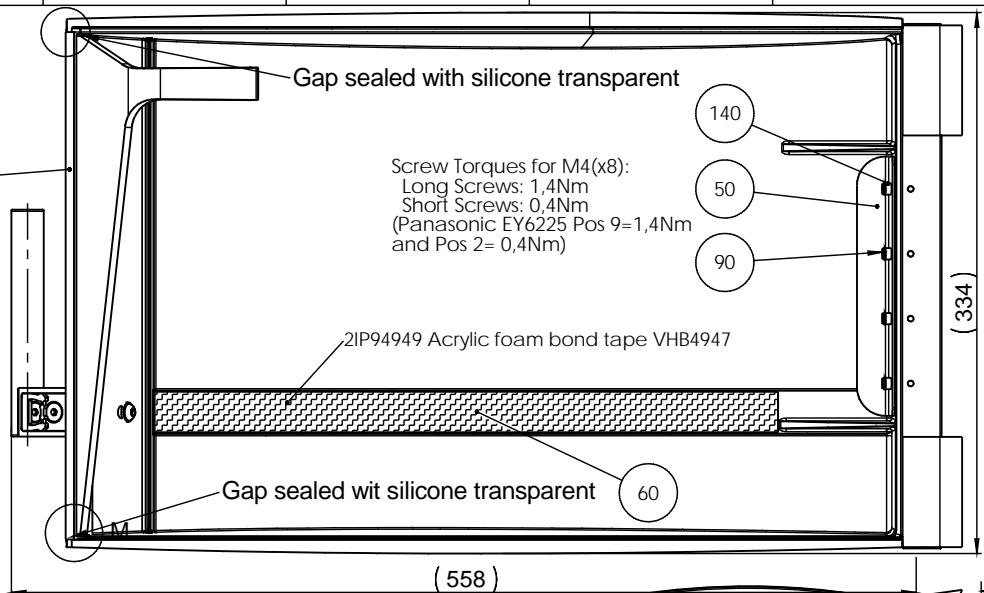
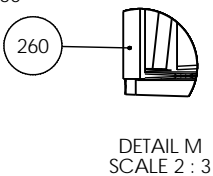
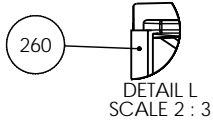

Degreased before assembly with isopropyl alcohol. (use Wonder wipes napkins)

SECTION A-A

Seal screw holes with High Vacuum Grease.

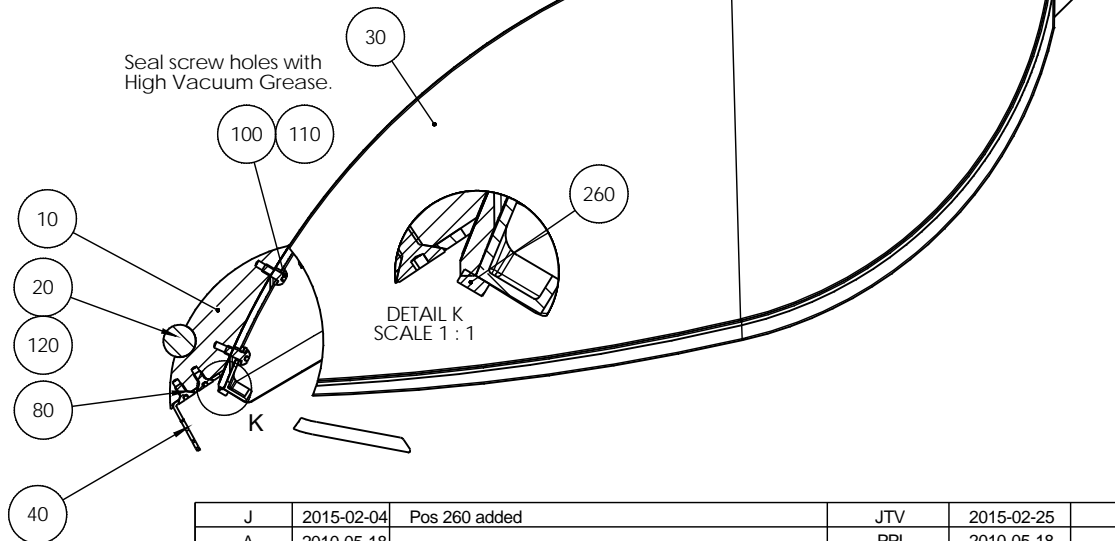

230 60 2IP94949 Acrylic foam tape VHB4947 25mm

J	2015-02-04	Pos 260 added	JTV	2015-02-25	JTV
A	2010-05-18		PPL	2010-05-18	AKN
Revision	Crea. date yyyy-mm-dd	Revision description	Draw. Init	Appr. date yyyy-mm-dd	Appr. Init
			Scale: 1:3	Format: A3	Tolerance: DS/ISO 2768- mK Surface treat.: None
ID: 15990016 Lid assembly			Description:		Rev: J

Pedersnapvej 84
 DK-2750 Ballerup/Copenhagen
 Denmark
 Phone: +45 44 600 800
 Fax: +45 44 600 804

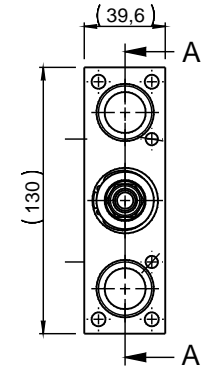
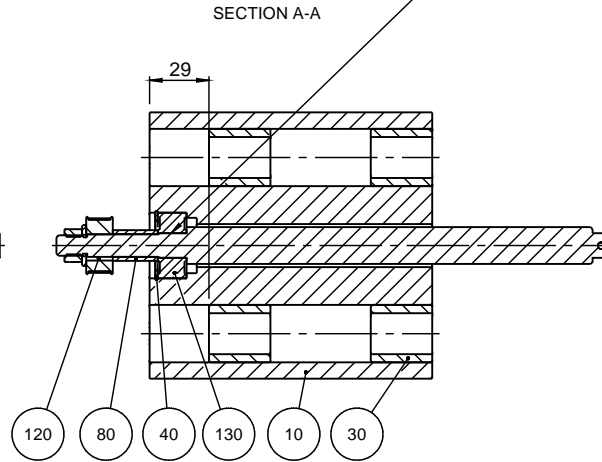
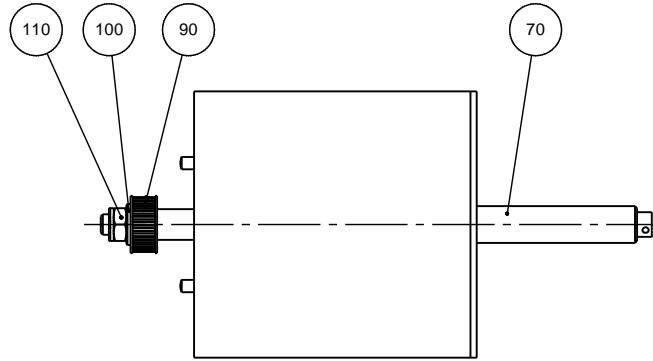

Note that the shaft must move easily through the bearing.
 Bemærk at akselen skal gå nemt igennem lejet.

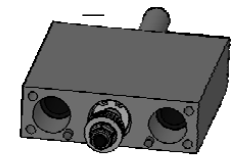
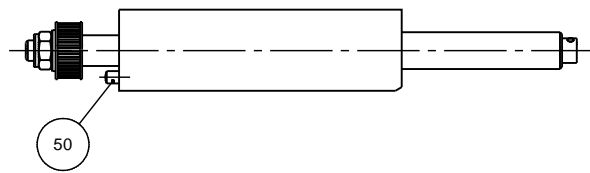

H	2016-06-06	C5: Pos. 60 -> pos. 130 new item.		JJO	2016-06-06	JTV
A	2010-05-18			PPL	2010-05-18	AKN
Revision	Crea. date yyyy-mm-dd	Revision description		Draw. Init	Appr. date yyyy-mm-dd	Appr. Init
		Material:	Scale: 1:2	Format: A3	Tolerance: DS/ISO 2768- mK	Weight : g
ID:		Description: 15990017 motor console support			Rev: H	

Pødenstrøvej 84
 DK-2720 Ballerup-Copenhagen
 Denmark
 Phone: +45 44 600 800
 Fax: +45 44 600 804

SECTION A-A

SECTION B-B

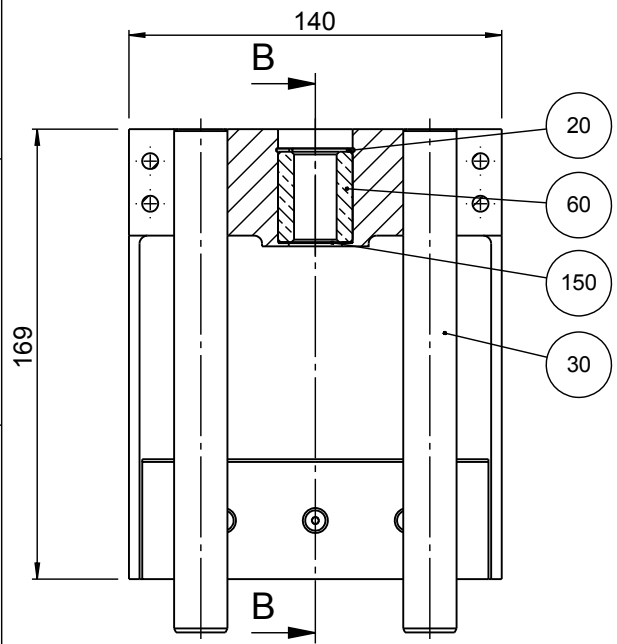

Der fyldes op med 0,1mm passkiver.
Fill up with 0,1mm shims.

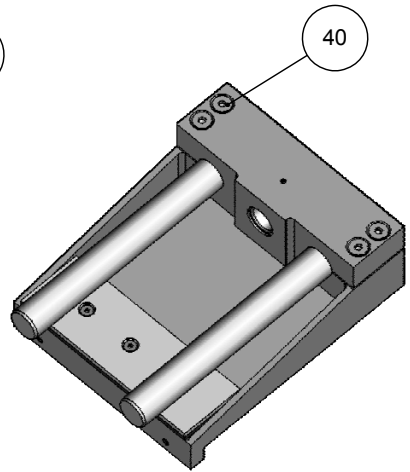
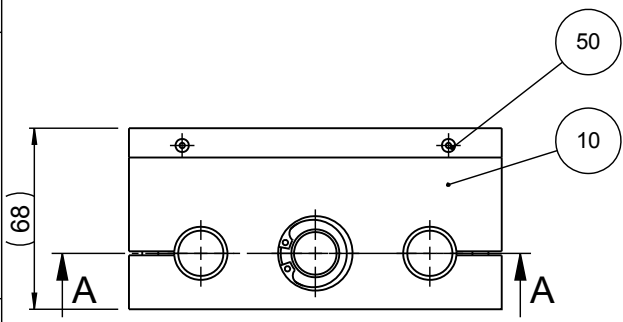
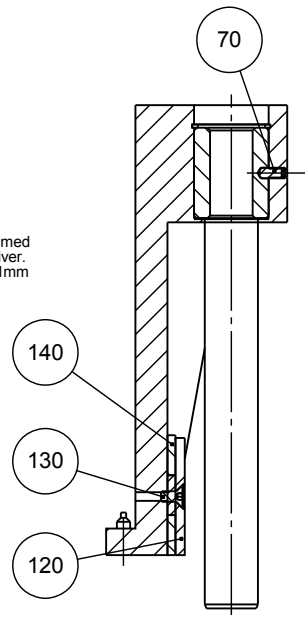

70 Insured by Loctite 243

40 Grease by 2LS0002 Albida Glease LX

I	2013-01-07	Pos. 50 new screws.	JJO		
A	2010-05-18		PPL	2010-05-18	AKN
Rev	Crea. date yyyy-mm-dd	Revision description	Draw. Init	Appr. date yyyy-mm-dd	Appr. Init
F	 Material:		Scale: 1:2	Format: A4	Tolerance: DS/ISO 2768 - mK Surface treat.: None
Pederstrupvej 84 DK-2750 Ballerup Copenhagen Denmark Phone :+45 44600 800 Fax : +45 44630 804		ID: 15990018 Description: Motor console			Rev: I

1

2

3

4

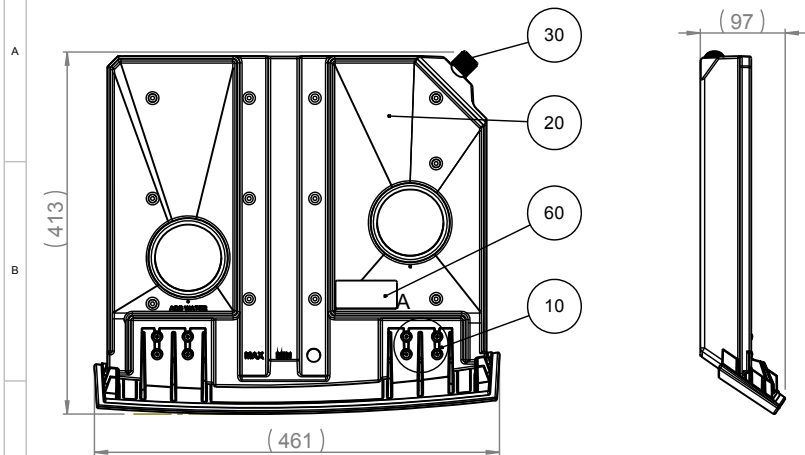

DETAIL A
SCALE 1 : 1

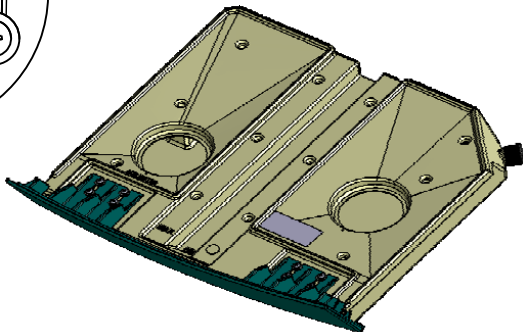
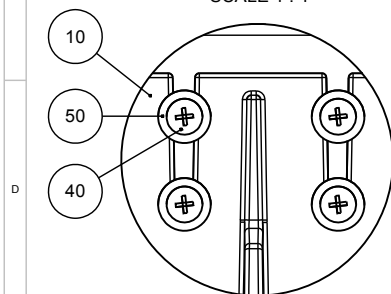

The density between the cap and tub tested with water.

D	2012-07-05	F,1: Text added about test.	JJO		
A	2010-05-13		PPL	2010-05-13	AKN
Rev	Crea. date yyyy-mm-dd	Revision description	Draw. Init	Appr. date yyyy-mm-dd	Appr. Init
F		Material:	Scale: 1:5	Format: A4	Tolerance: DS/ISO 2768 - mK Surface treat.: None
	ID:	Description: 15990019 reservoir complete		Rev:	D

Pederstrupvej 84
 DK-2750 Ballerup
 Copenhagen
 Denmark
 Phone: +45 44600 800
 Fax: +45 44600 804

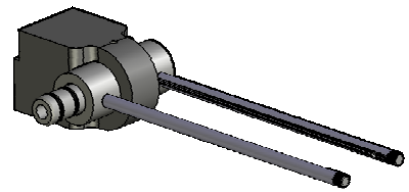
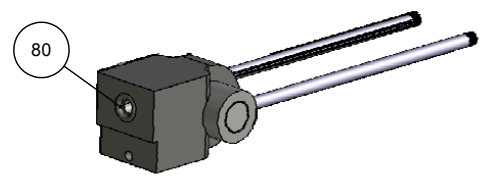
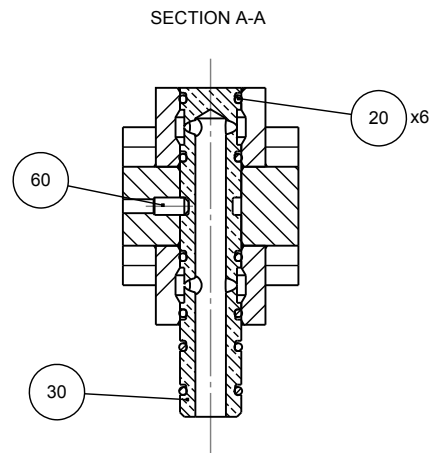
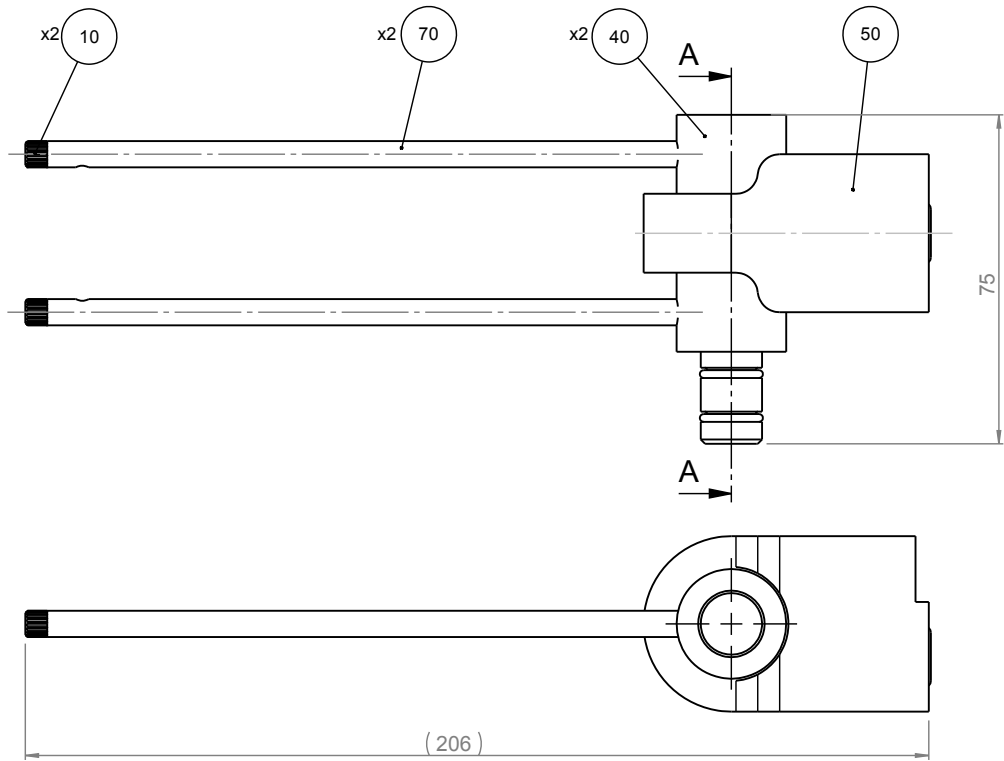

- (20) (80) Smear with high vacuum grease
- (70) (40) Glue with Loctite 577

C	2012-07-23	E,5: Text added.	JJO		
A	2010-01-19		PPL	2010-01-19	AKN
Revision	Crea. date yyyy-mm-dd	Revision description	Draw. Init	Appr. date yyyy-mm-dd	Appr. Init
		Material:	Scale: 1:1	Format: A3	Tolerance: DS/ISO 2768- Surface treat.: None
ID:	Description: 15990021 Cooling nozzles		Rev:	C	

Struers
 Pedersborgvej 84
 DK-2750 Ballerup/Copenhagen
 Denmark
 Phone: +45 44 600 800
 Fax: +45 44 600 804

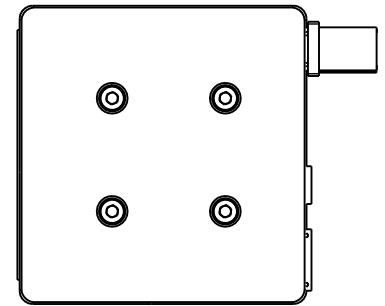
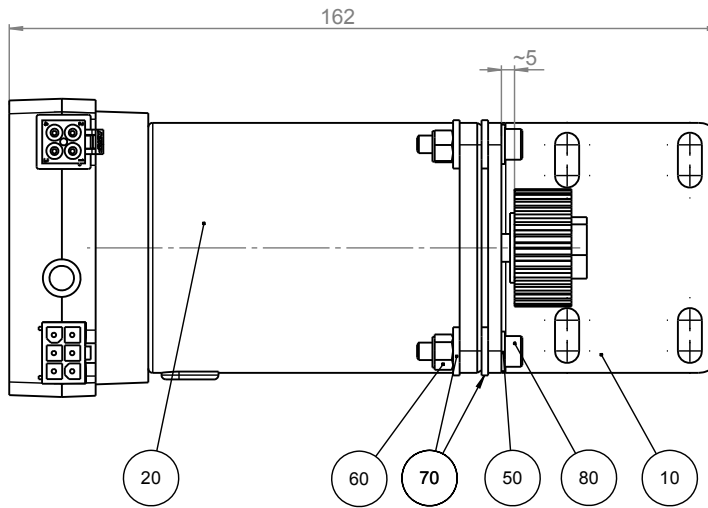
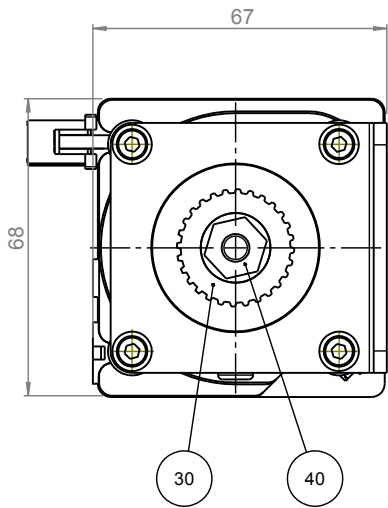

Have to be removed
before mounting in base frame.

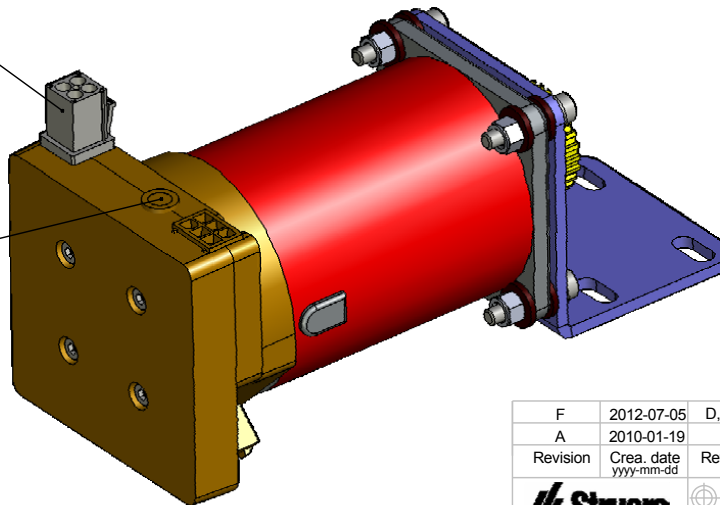

Address switch 1
look at circuit diagram 15993100

F	2012-07-05	D,1 and F,1: Text added.		JJO	
A	2010-01-19			PPL	AKN
Revision	Crea. date yyyy-mm-dd	Revision description		Draw. Init	Appr. date yyyy-mm-dd
		Material:		Scale: 1:1	Format: A3
		ID:		Tolerance: DS/ISO 2768- mK	
		Description:		Surface treat.: None	
15990022 step motor elevation - complete				Rev: F	



Turn the ventilation slot to the pulley wheel.

DETAIL C
SCALE 2 : 1

(345)

(R27)

SECTION A-A

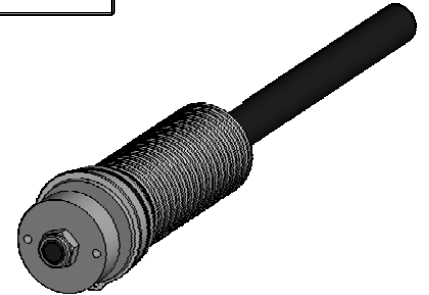

D	2012-07-19	Pos. 120 added.	JJO		
A	2010-01-19		PPL	2010-01-19	AKN
Revision	Crea. date yyy-mm-dd	Revision description	Draw. Init	Appr. date yyy-mm-dd	Appr. Init
	Material:	Scale: 1:1	Format: A3	Tolerance: DS/ISO 2768- mK	
				Surface treat.: None	
ID:	Description:				Rev:
	15990024 Y-shaft				D

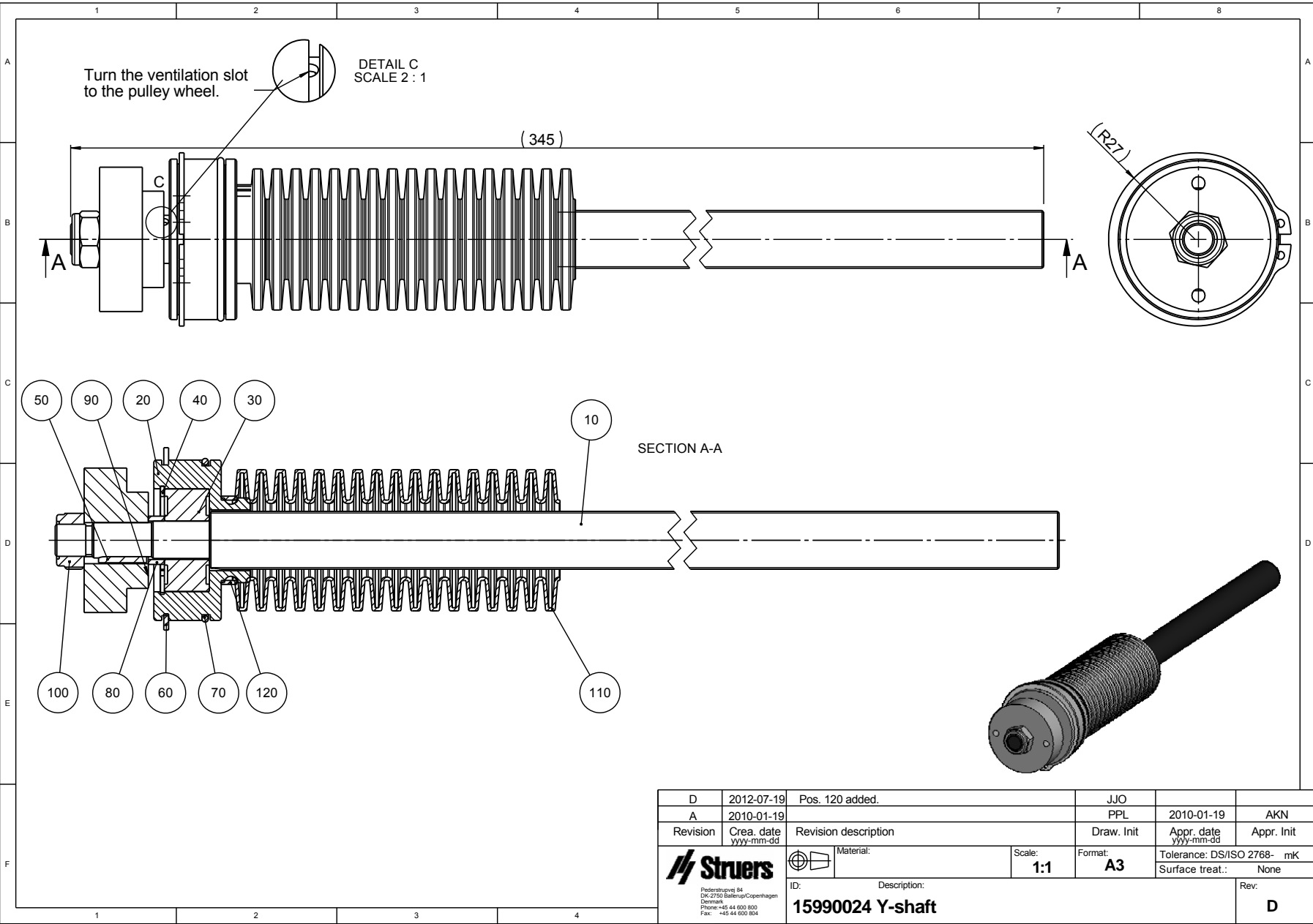

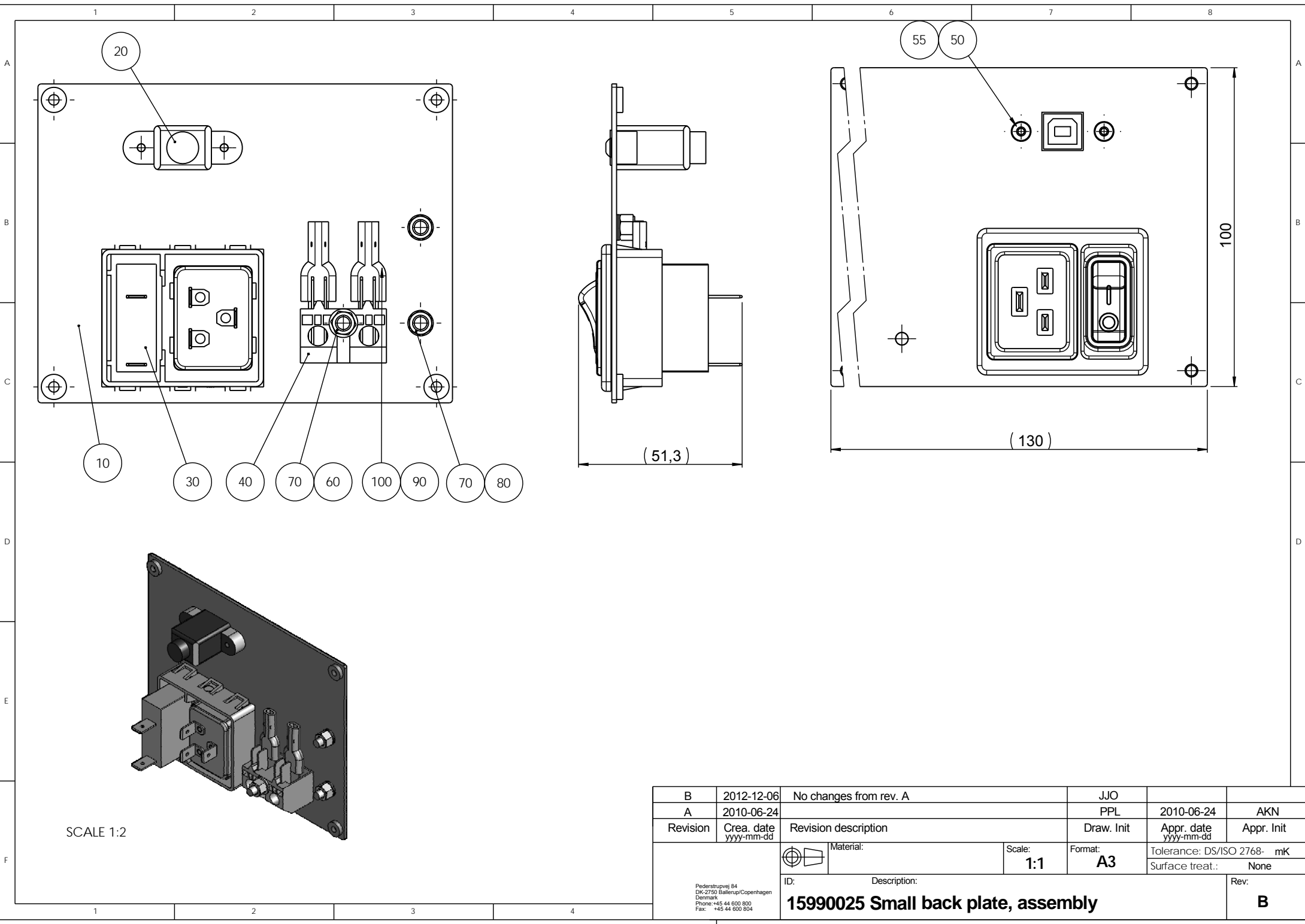

SCALE 1:2

B	2012-12-06	No changes from rev. A	JJO		
A	2010-06-24		PPL	2010-06-24	AKN
Revision	Crea. date yyyy-mm-dd	Revision description	Draw. Init	Appr. date yyyy-mm-dd	Appr. Init
		Material:	Scale: 1:1	Format: A3	Tolerance: DS/ISO 2768- mK
		ID:	Description:		Surface treat.: None
<p>Pederstrupvej 84 DK-2750 Ballerup/Copenhagen Denmark Phone: +45 44 600 800 Fax: +45 44 600 804</p> <p>15990025 Small back plate, assembly</p>					Rev: B

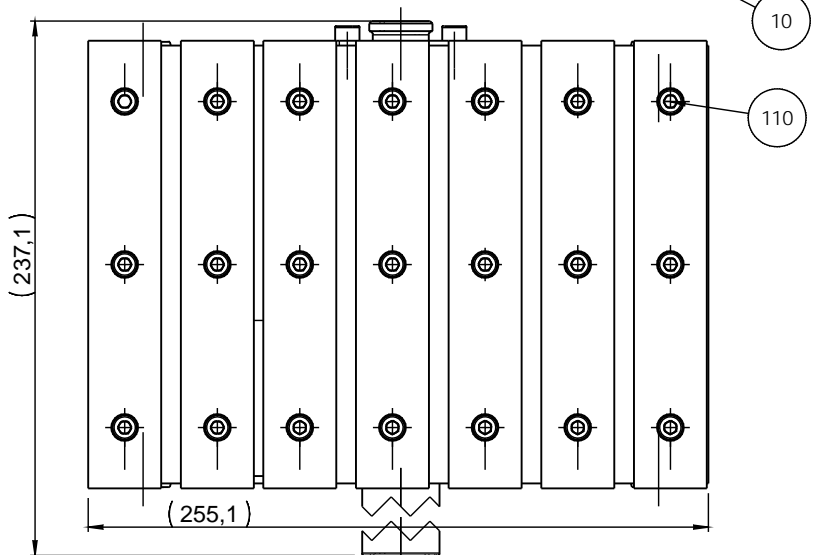
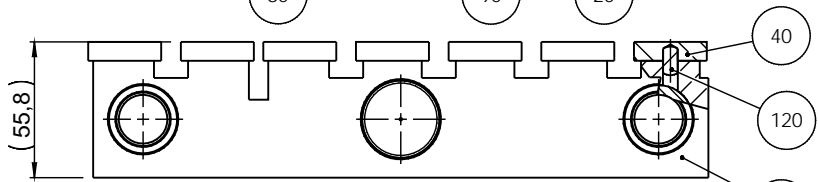
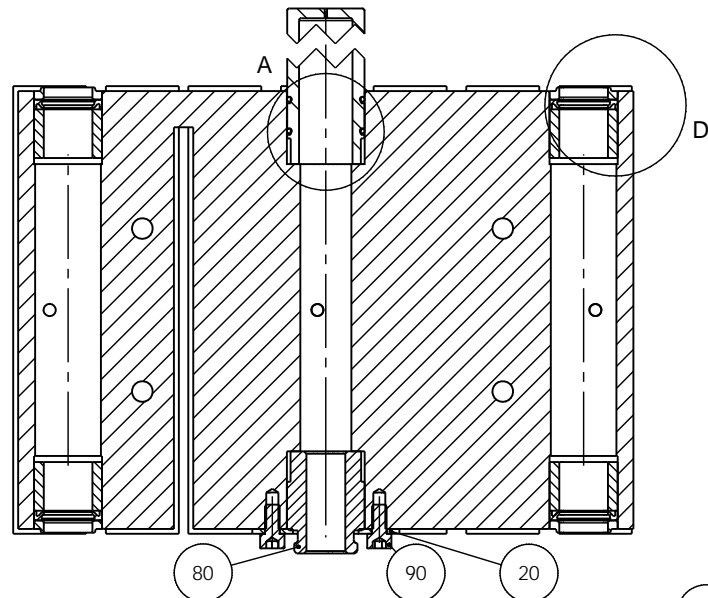

DETAIL A
SCALE 2 : 1

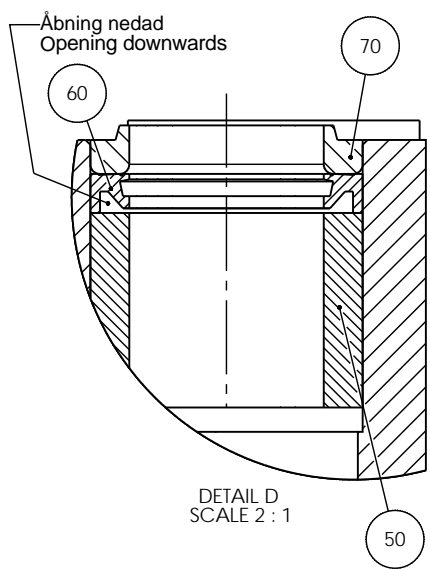
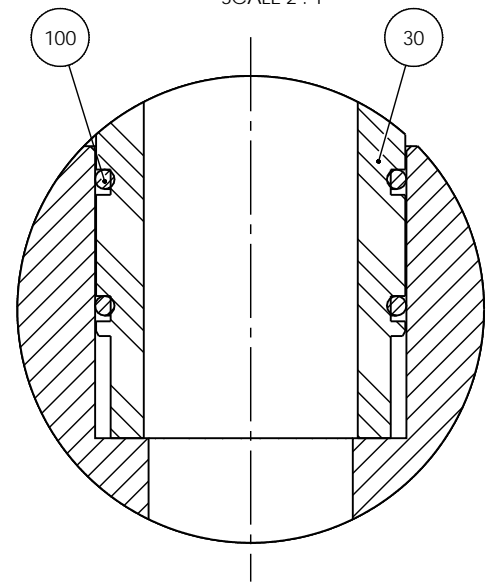

DETAIL D
SCALE 2 : 1

- 40 Smør 2LS10417 Klübersynth MZ 4-17 under pladerne.
- 40 Kontroller afstand og facon på samtlige 8mm T-spor. (testværktøj 10161506)
- 50 Fedtes let ind med Albida fedt og ipresses med værktøj 15031500 til første streg.
- 60 I presses med værktøj 15031500
- 70 I presses med værktøj 15031500
- 110 Antisize grease 785 FG

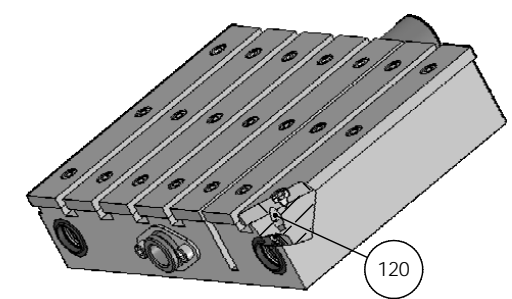

E	2014-11-07	pos. 60 corrected	OCR	2014-11-12	JJO/JTV
A	2010-01-19		PPL	2010-01-19	AKN
Revision	Crea. date yyyy-mm-dd	Revision description	Draw. Init	Appr. date yyyy-mm-dd	Appr. Init
		Material:	Scale: 1:2	Format: A3	Tolerance: DS/ISO 2768- mK Surface treat.: None
Pederstrupvej 84 DK-2750 Ballerup/Copenhagen Denmark Phone: +45 44 600 800 Fax: +45 44 600 804		ID:	Description:		Rev:
15990026 Y-table-assembly					E

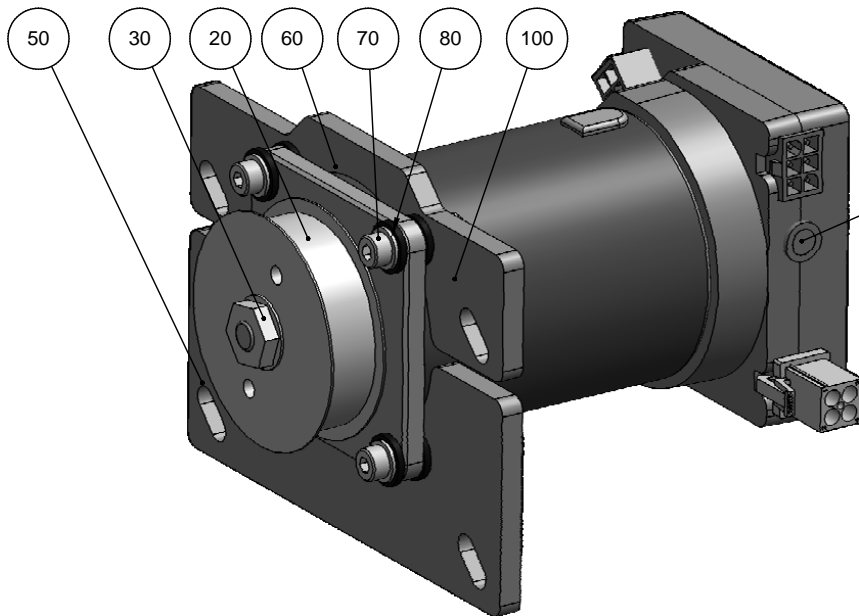
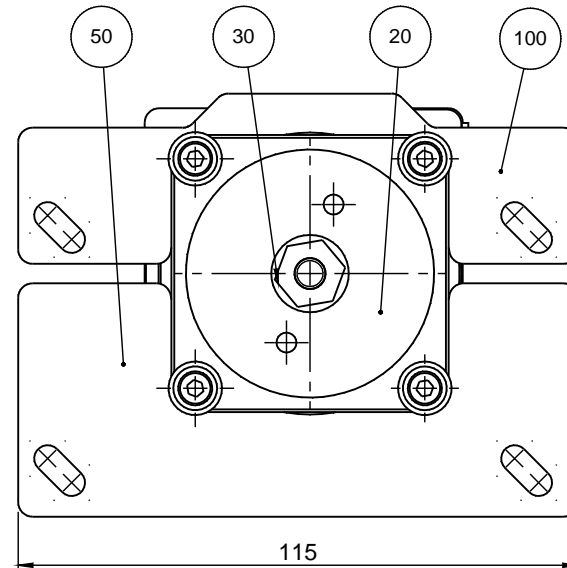
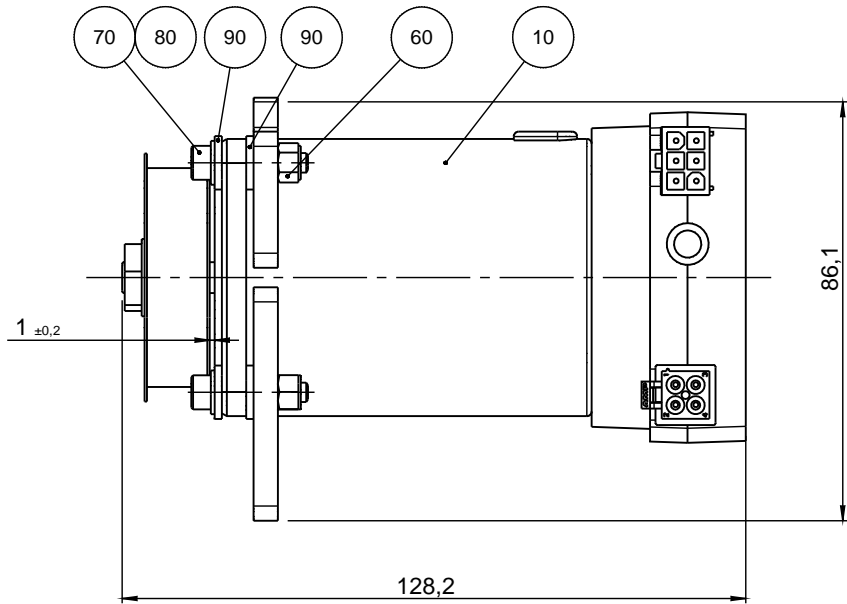

Adress switch F. Look at circuit diagram 15993100

E	2015-02-19	B1: Distance 1±0,2 added. Pos. 40 washer deleted	JJO	2015-02-19	JTV
A	2010-01-20		PPL	2010-01-20	AKN
Revision	Crea. date yyyy-mm-dd	Revision description	Draw. Init	Appr. date yyyy-mm-dd	Appr. Init
 <small>Pedersbølvej 84 DK-2760 Søborg/Copenhagen Denmark Phone: +45 44 600 800 Fax: +45 44 600 804</small>	Material:	Scale: 1:1	Format: A3	Tolerance: DS/ISO 2768- mK	Surface treat.: None
	ID:	Description:	Rev:		
15990027 Y-table-steppmotor-assembly					E

A

B

C

D

E

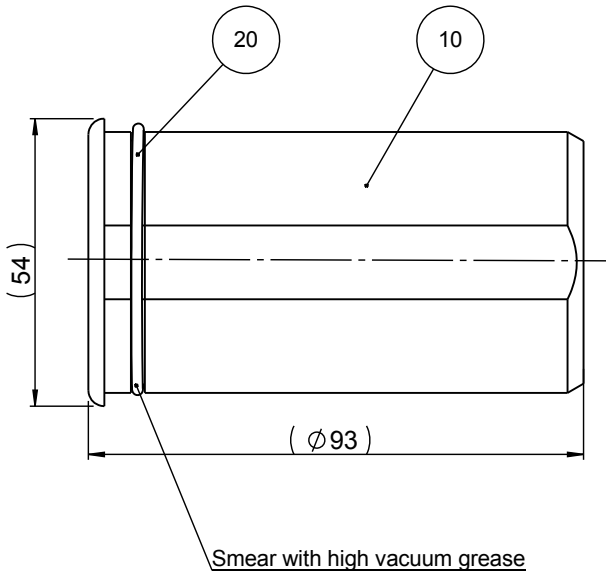

F

D	2012-07-24	D,2: Text added.	JJO			
A	2010-01-18		PPL	2010-01-18	AKN	
Rev	Crea. date yyyy-mm-dd	Revision description	Draw. Init	Appr. date yyyy-mm-dd	Appr. Init	
		Material:	Scale: 1:1	Format: A4	Tolerance: DS/ISO 2768 - - Surface treat.: None	
Pederstrupvej 84 DK-2750 Ballerup Copenhagen Denmark Phone: +45 44600 800 Fax: +45 44600 804		ID:	Description: 15990028 Ventilation-assembly			Rev: D

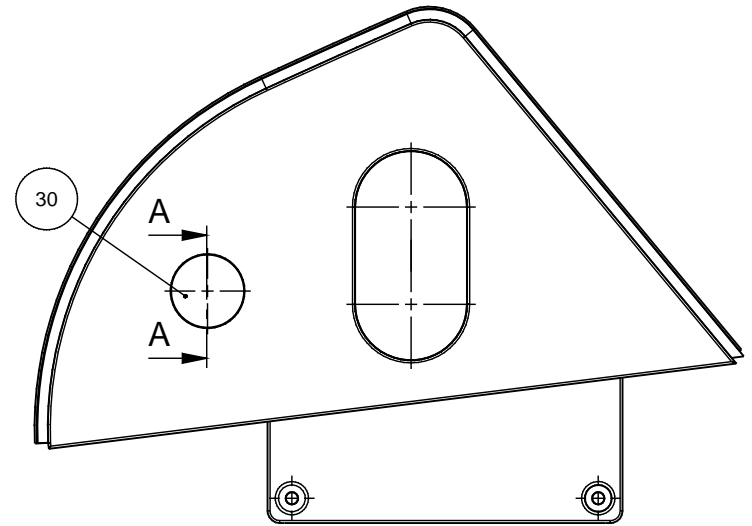
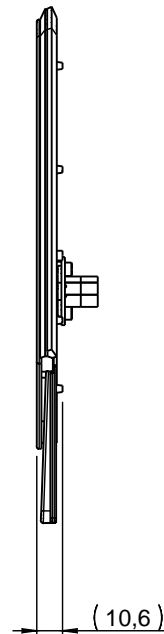
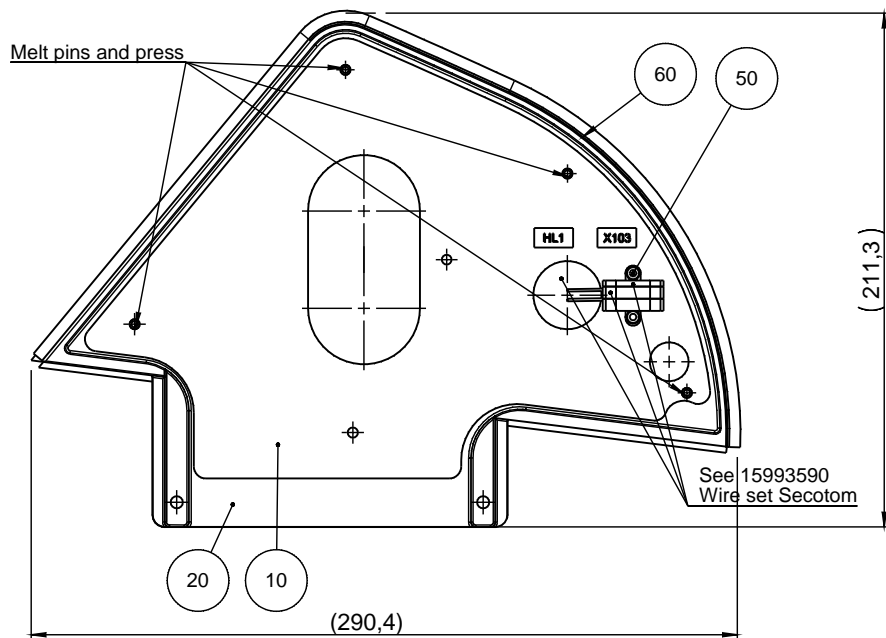

Window and blinder cleaned with IPA alcohol. Glue surface must be clean dry and free of grease. Place a glue line all the way around the blinder. Use 2LL00330 Universal Silicone 512. Press the window into the blinder. Possibly remove excess silicone having a toothpick. The window must be waterproof.

Ruden og blinder renses af med IPA sprit. Lim fladerne skal være rene, tørre og fri for fedtstof. Der lægges en limfuge hele vejen rundt i blinderen. Anvend 2LL00330 Universal Silicone 512. Ruden presses i. Eventuelt fjern overskydende silicone med en tandstikker. Ruden skal være vandtæt.

SECTION A-A
SCALE 1 : 1

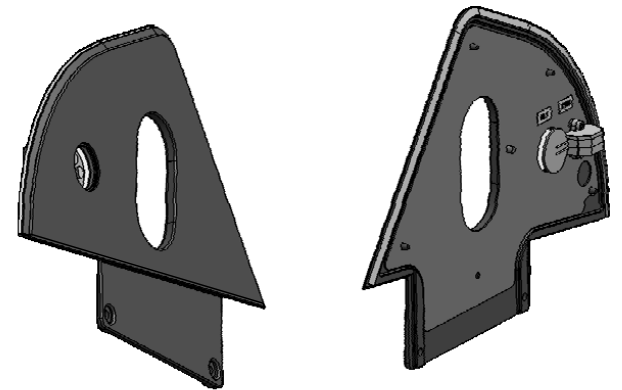
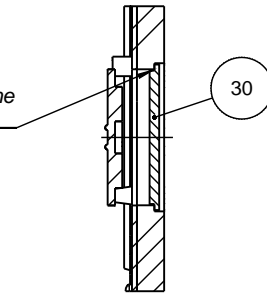

F	2016-01-19	D1: Glue regulatory added.		JJO	2016-01-19	JTV
A	2010-01-20			PPL	2010-01-20	AKN
Revision	Crea. date yyyy-mm-dd	Revision description		Draw. Init	Appr. date yyyy-mm-dd	Appr. Init
		Material:		Scale: 1:2	Format: A3	Tolerance: DS/ISO 2768- mK Surface treat.: None
ID:	Description:		15990032 Blinder - complete		Rev:	F

Peberstrøvej 84
DK-2750 Ballerup/Copenhagen
Denmark
Phone: +45 44 600 800
Fax: +45 44 600 804

To ensure maximal effect and lifetime of the pump and tube:

- Lubricate the tube along its length with the silicon grease enclosed (this will help the rollers in the pump to turn smoothly).
- Mount the tube correctly in the pump:

Correct:



Incorrect:



Too loose

Too tight

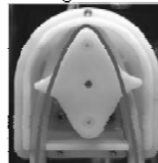

Excess volume between the rollers will press "waves" of fluid which will stretch the tube; lifetime of the tube will be reduced.

The tube is stretched; lifetime of the tube will be reduced.

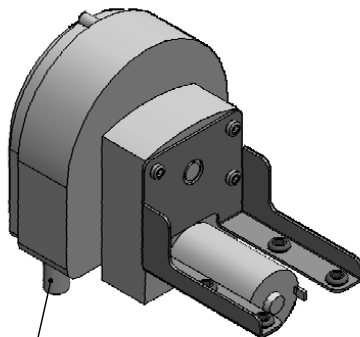
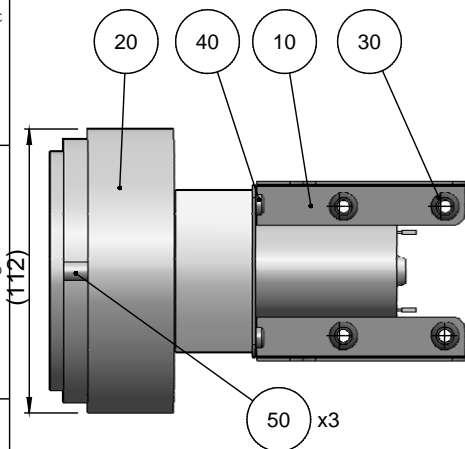
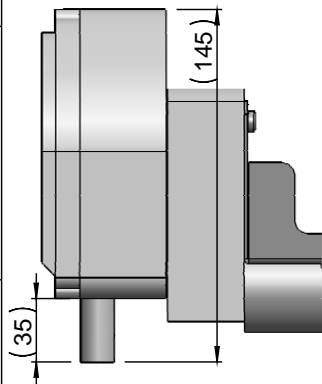

Spare parts no. for hose autoprene 2NU14824

See PF 15997360 for how to replace thread insert (50), rework of gear and greasing of pump hose.

H	2015-11-11	Pos 50 + PF 15997360 and text added	JTV	2015-11-11	JTV
A	2010-05-12		PPL	2010-05-12	AKN
Rev	Crea. date yyyy-mm-dd	Revision description	Draw. Init	Appr. date yyyy-mm-dd	Appr. Init
F		Material:	Scale: 1:2	Format: A4	Tolerance: DS/ISO 2768 - mK Weight : g
	ID:	Description: 15990033 Pump - complete		Rev: H	

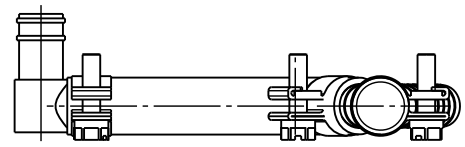
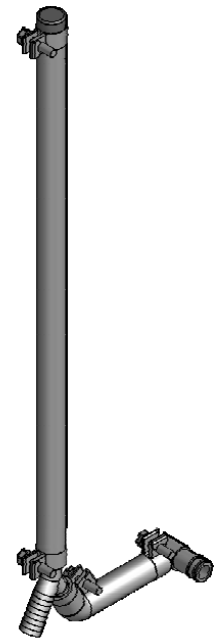
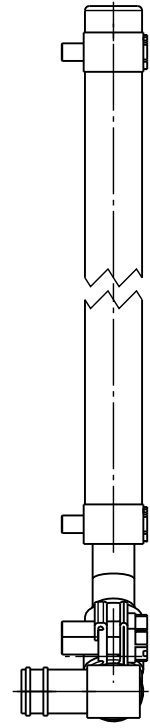
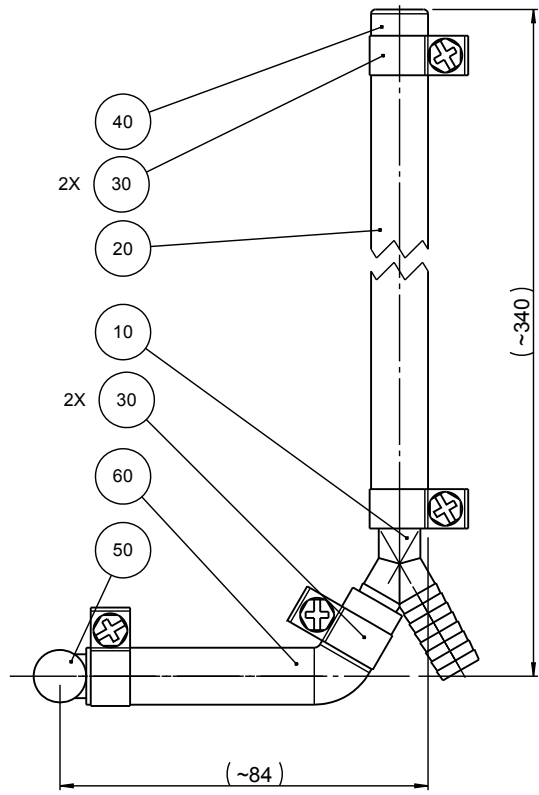

G	2012-07-26	F.6: Text deleted.	JJO		
A	2010-05-13		PPL	2010-05-13	AKN
Revision	Crea. date yyy-mm-dd	Revision description	Draw. Init	Appr. date yyy-mm-dd	Appr. Init
Material:		Scale: 1:1	Format: A3	Tolerance: DS/ISO 2768- mK	
ID: Description:			Weight :		g
15990034 Absorber - assembly					Rev: G

Struers
 Pedersbucvej 64
 DK-2750 Ballerup/Copenhagen
 Denmark
 Phone: +45 44 600 800
 Fax: +45 44 600 504

1

2

3

4

A

B

C

D

E

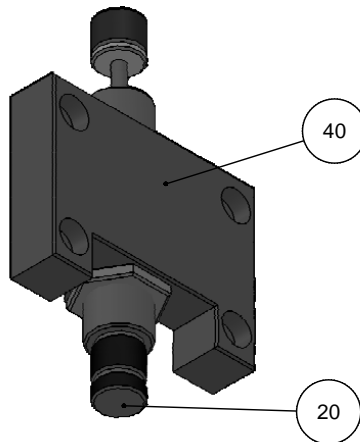
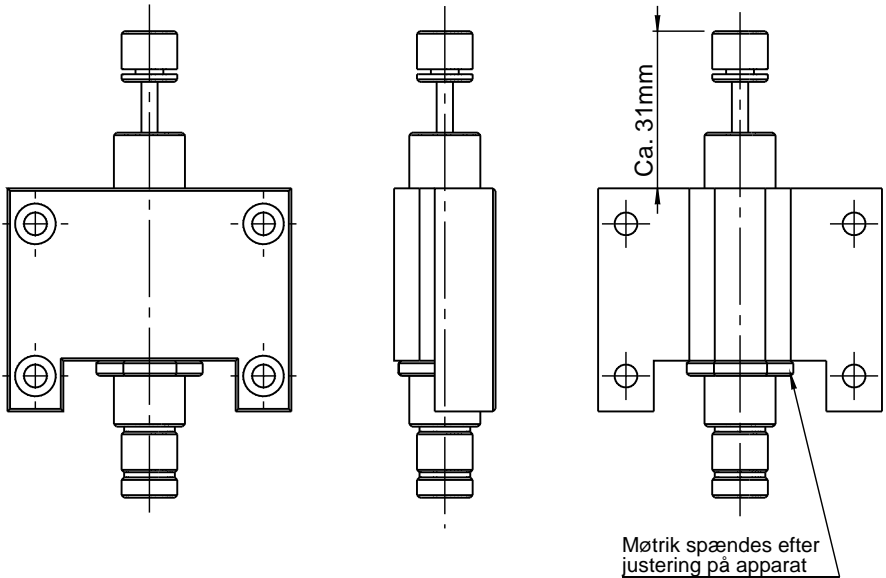

C	2014-09-15	Pos. 20 2YS10025 leveres med 1 møtrik	OCR	2014-09-15	JTV
A	2010-06-07		FPG	2010-06-07	FPG
Rev	Crea. date yyyy-mm-dd	Revision description	Draw. Init	Appr. date yyyy-mm-dd	Appr. Init
F	 Pederstrupvej 84 DK-2750 Ballerup Denmark Phone :+45 44600 800 Fax : +45 44600 804	Material:	Scale: 1:1	Format: A4	Tolerance: DS/ISO 2768 - mK Surface treat.: None
		ID:	Description: 15990074 Damper, assembly		

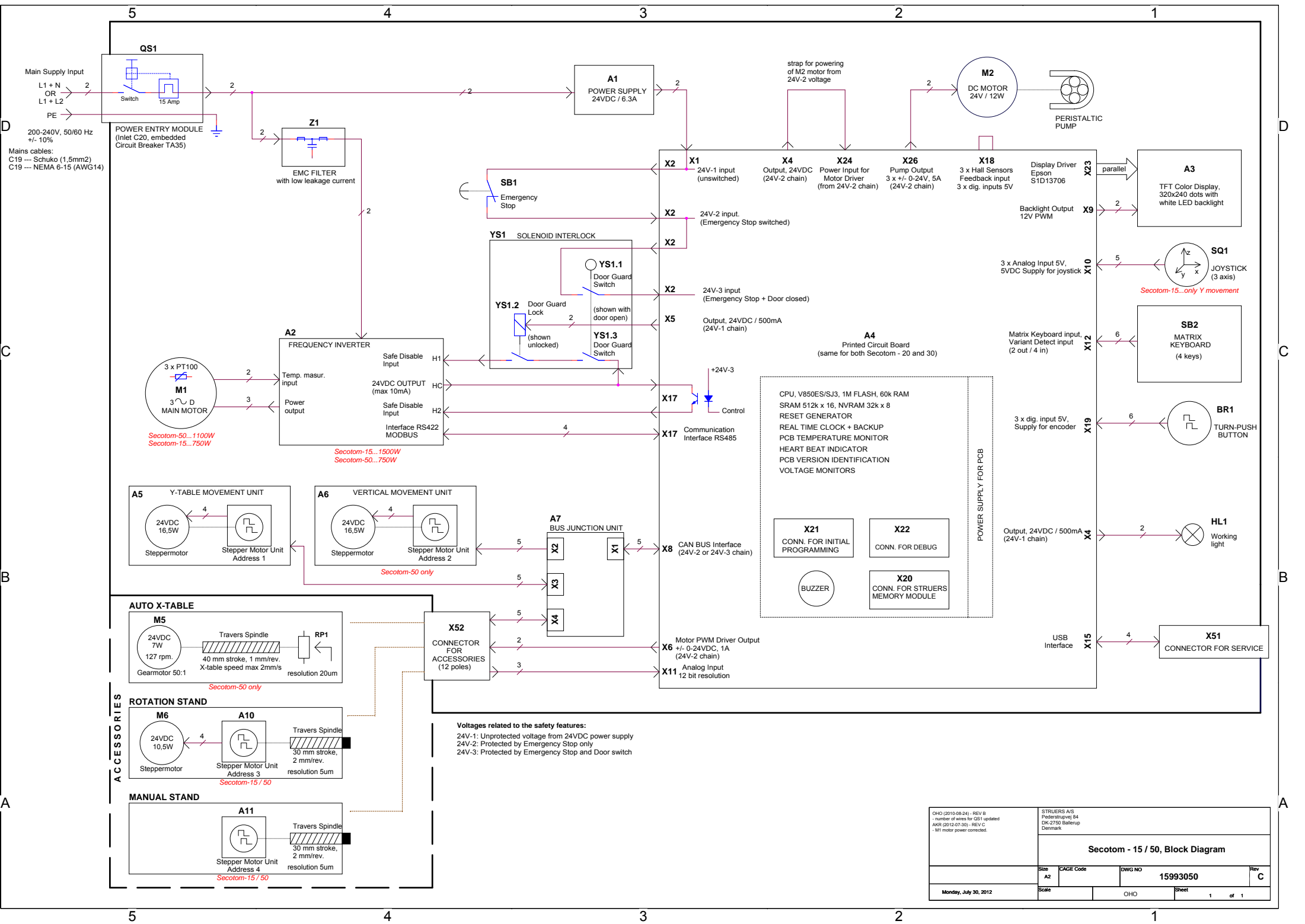

DHO (2010-08-24) - REV B number of wires for G51 updated AKR (2012-07-30) - REV C M1 motor power corrected.		STRUERS AS Pedestri@sup@ve B4 DK-2750 Ballerup Denmark	
Secotom - 15 / 50, Block Diagram			
Size A2	CAGE Code	DWG NO 15993050	Rev C
Monday, July 30, 2012	Scale	OHO	Sheet 1 of 1

External short circuit protection according to local regulations.

Main Supply Input
200-240V, 50/60 Hz
+/- 10%

Mains cables:
C19 --- Schuko (1,5mm²)
C19 --- NEMA 6-15 (AWG14)

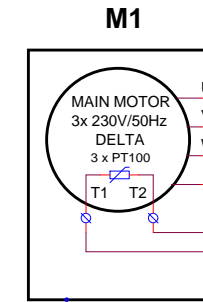

Secotom-50...1100W
Secotom-15...750W

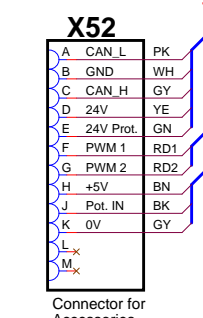
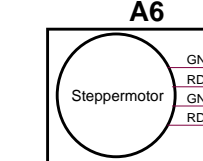
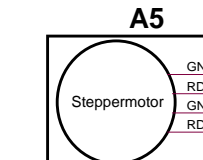

Connector for Accessories

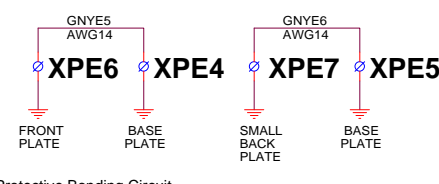
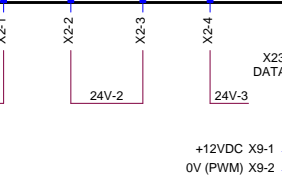
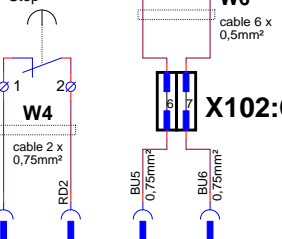
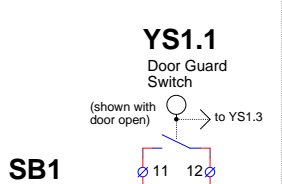
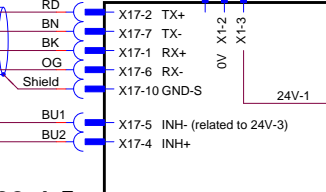
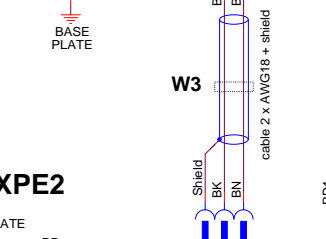
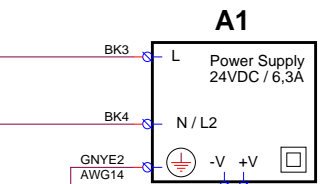
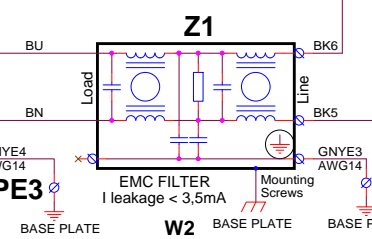
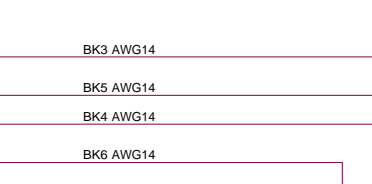
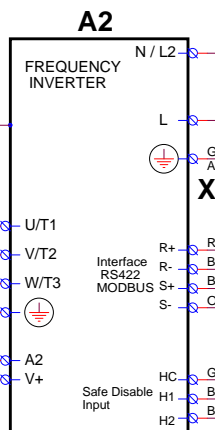
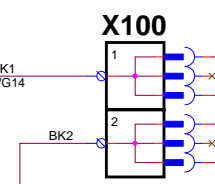
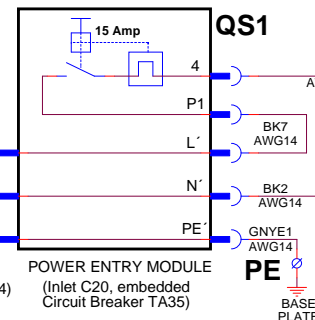

COLOR CODE:
BK = black
BN = brown
RD = red
OG = orange
YE = yellow
GN = green
BU = blue
VT = violet
GY = grey
WH = white
PK = pink
BE = beige
RO = rose
GNYE = yellow-green

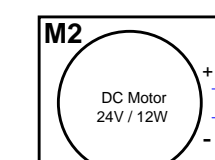
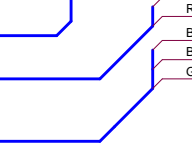
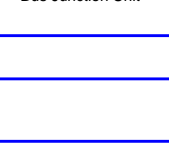
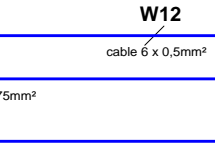
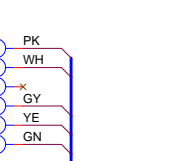
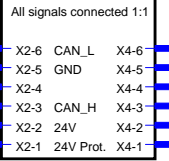
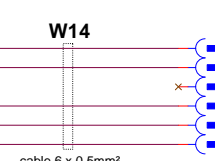
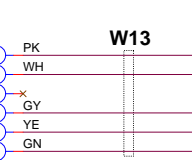
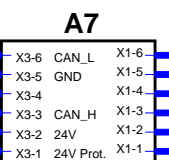
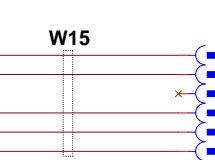
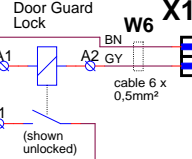
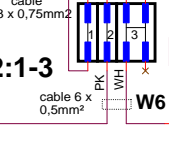
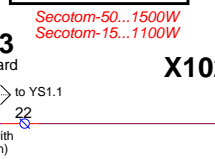

DC Motor 24V / 12W

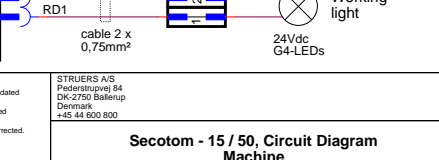
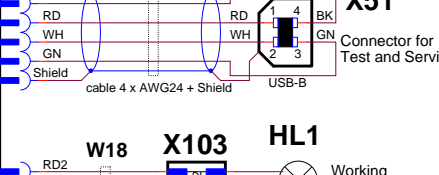
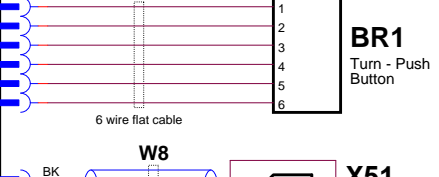
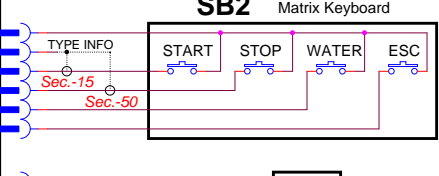
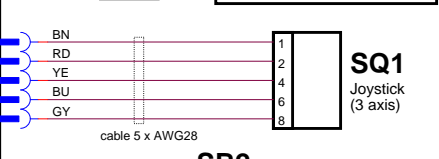
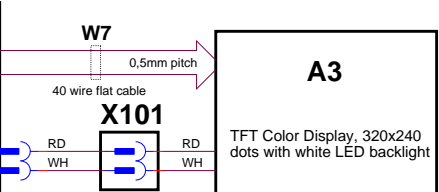
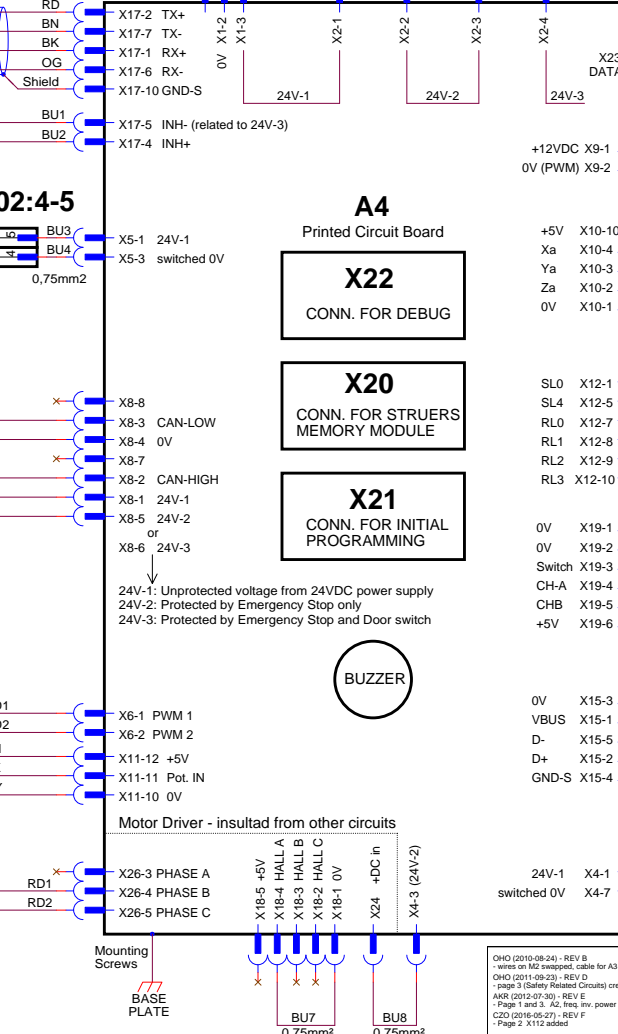

Secotom - 15 / 50, Circuit Diagram Machine

OHO (2010-08-24) - REV B
- wires on M2 swapped, cables for A3 updated
OHO (2011-09-23) - REV D
- page 3 (Safety Related Circuits) created
AKR (2012-07-30) - REV E
- Page 1 and 3, A2, freq. inv. power corrected.
CDO (2016-05-27) - REV F
- Page 2, X112 added

Size	A2	CAGE Code	DWG NO	Rev
Scale			15993100	F

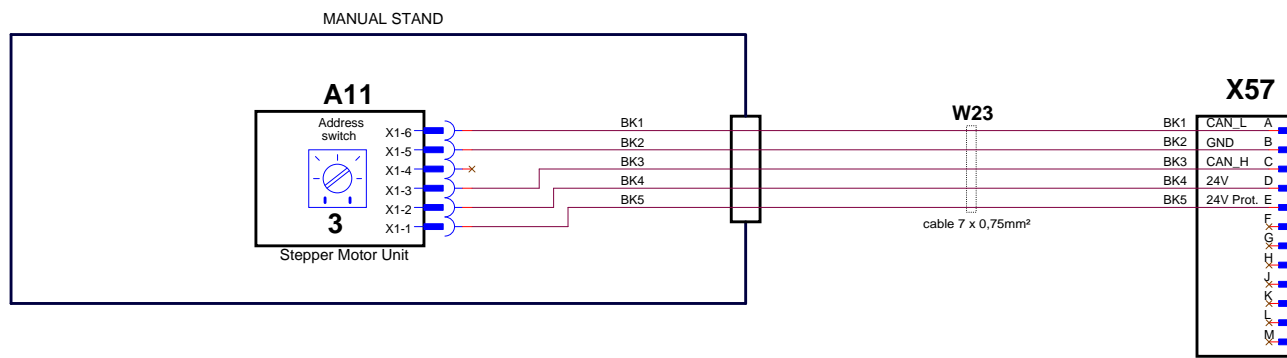
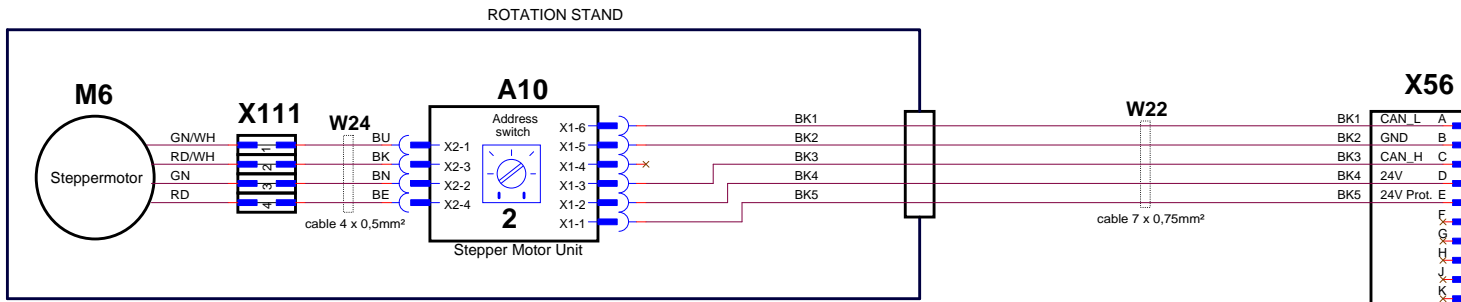
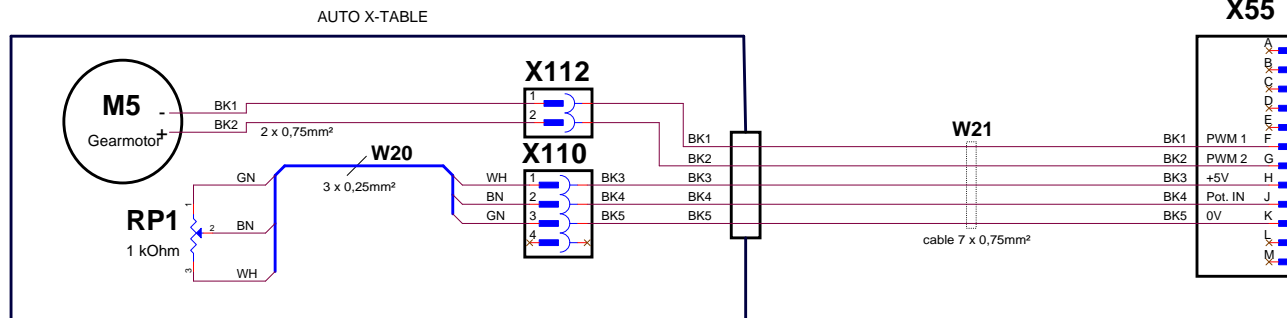

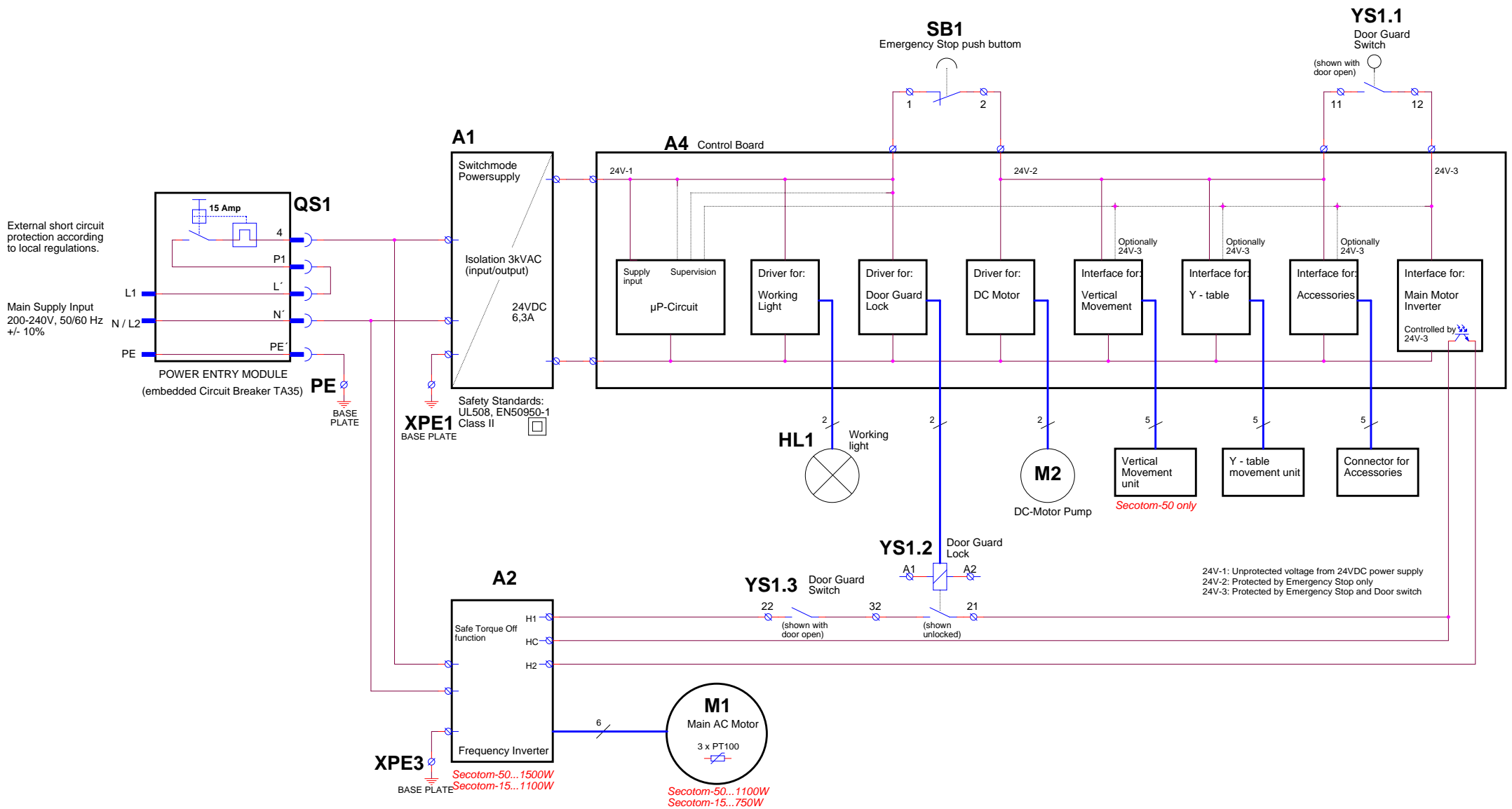

OHO (2011-09-23) - REV D - page 3 (Safety Related Circuits) created AND (2012-07-30) - REV E - Page 1 and 3, A2, freq. inv. power corrected. C20 (2016-05-27) - REV F - Page 2, X112 added		STRUERS A/S Reiserstrupvej 84 DK-2750 Ballerup Denmark +45 44 600 800	
Secotom - 15 / 50, Circuit Diagram Safety Related Circuits			
Size A2	CAGE Code	DWG NO 15993100	Rev F
Friday, May 27, 2016	Scale	OHO	Sheet 3 of 3



Pederstrupvej 84
DK-2750 Ballerup
Denmark