

LaboForce-100

Instruction Manual



Manual No.: 16367001

Date of Release:2017.07.17

LaboDoser-100

Instruction Manual



LaboForce-100
LaboDoser-100
Instruction Manual

FCC Notice

This equipment has been tested and found to comply with the limits for a Class A digital device, pursuant to Part 15 of the FCC Rules. These limits are designed to provide reasonable protection against harmful interference when the equipment is operated in a commercial environment. This equipment generates, uses, and can radiate radio frequency energy and, if not installed and used in accordance with the Instruction Manual, may cause harmful interference to radio communications. Operation of this equipment in a residential area is likely to cause harmful interference in which case the user will be required to correct the interference at his own expense.

Pursuant to Part 15.21 of the FCC Rules, any changes or modifications to this product not expressly approved by Struers could cause harmful radio interference and void the user's authority to operate the equipment.

Always state *Serial No* and *Voltage/frequency* if you have technical questions or when ordering spare parts. You will find the Serial No. and Voltage on the type plate of the machine itself. We may also need the *Date* and *Article No* of the manual. This information is found on the front cover.

The following restrictions should be observed, as violation of the restrictions may cause cancellation of Struers legal obligations:

Instruction Manuals: Struers Instruction Manuals may only be used in connection with Struers equipment covered by the Instruction Manual.

Service Manuals: Struers Service Manuals may only be used by a trained technician authorised by Struers. The Service Manual may only be used in connection with Struers equipment covered by the Service Manual.

Struers assumes no responsibility for errors in the manual text/illustrations. The information in this manual is subject to change without notice. The manual may mention accessories or parts not included in the present version of the equipment.

Original instructions. The content of this manual are the property of Struers. Reproduction of any part of this manual without the written permission of Struers is not allowed.

All rights reserved. © Struers 2017.

Struers
Pederstrupvej 84
DK-2750 Ballerup
Denmark
Telephone +45 44 600 800
Fax +45 44 600 801



LaboForce-100 Safety Precaution Sheet

To be read carefully before use

1. The operator should be fully aware of the use of the machine according to the Instruction Manual.
2. Keep your hands clear of the specimen holder or specimen mover plate when lowering LaboForce.
3. Do not touch the rotating parts during operation.
4. When working at machines with rotating parts care has to be taken that clothing and/or hair cannot be caught by the rotating parts. Appropriate safety clothing must be used.
5. If you observe malfunctions or hear unusual noises - stop the machine and call technical service.
6. Alcohol based consumables: follow the current safety rules for handling, mixing, filling, emptying and disposal of the alcohol-based liquids.
7. The LaboForce must be mounted securely on the LaboPol grinding/polishing machine
If the LaboPol has to be moved to a new location, remove LaboForce before moving the grinding/polishing machine (See section Installing LaboForce).

The equipment should only be used for its intended purpose and as detailed in the Instruction Manual.

The equipment is designed for use with consumables supplied by Struers. If subjected to misuse, improper installation, alteration, neglect, accident or improper repair, Struers will accept no responsibility for damage(s) to the user or the equipment.

Dismantling of any part of the equipment, during service or repair, should always be performed by a qualified technician (electromechanical, electronic, mechanical, pneumatic, etc.).



LaboDoser-100 Safety Precaution Sheet

1. The operator(s) should be fully instructed in the use of the equipment, any connected equipment and accessories and the applied consumables according to the relevant Instruction Manuals.
2. The equipment must be placed on a safe and stable table with an adequate working height. All functions on the machine and any connected equipment must be in working order.
3. Alcohol based consumables: follow the current safety rules for handling, mixing, filling, emptying and disposal of the alcohol-based liquids.
4. If you observe malfunctions or hear unusual noises - stop the equipment and call technical service.

The equipment should only be used for its intended purpose and as detailed in the Instruction Manual.

The equipment is designed for use with consumables supplied by Struers. If subjected to misuse, improper installation, alteration, neglect, accident or improper repair, Struers will accept no responsibility for damage(s) to the user or the equipment.

Dismantling of any part of the equipment, during service or repair, should always be performed by a qualified technician (electromechanical, electronic, mechanical, pneumatic, etc.).



Disposal

Equipment marked with a WEEE symbol  contain electrical and electronic components and must not be disposed of as general waste.

Please contact your local authorities for information on the correct method of disposal in accordance with national legislation.

User's Guide

Table of Contents	Page
1. Getting Started	
Checking the Contents	3
Unpacking LaboForce-100	3
Placing LaboForce-100	3
Getting Acquainted with LaboForce-100	4
Mounting LaboForce-100	6
Electrical Connection.....	6
Compressed Air Connections.....	7
Emptying the Water / Oil Filter.....	7
Inserting Specimen Holders or Specimen Mover Plates	8
Inserting a Specimen Holder	8
Inserting a Specimen Mover Plate.....	8
Lowering the Specimen Mover Head.....	8
Adjusting the Specimen Mover Position	9
Height of Specimen Mover	9
Adjusting the Horizontal Position of the Specimen Holder/ Mover Plate.....	10
2. Connecting a LaboDoser-100	
Checking the Contents of the Packing Box.....	12
Mounting the Dosing Modules	12
3. Basic Operation of LaboForce-100	
LaboForce-100 Control Panel	14
Front Panel Controls	15
Reading the Display	16
Manoeuvring in the Menu Structure	17
Software Settings	18
Changing the Language.....	20
Editing Numeric Values	22
Editing Alphanumeric Values	23
Operation Mode	25
Changing Operation Mode	25
New Pass Code	26
User Surfaces	27
Selecting a Preparation Mode	29
Selecting a Preparation Method	30
Editing a Preparation Method.....	32
Renaming a Method.....	34

LaboForce-100
LaboDoser-100
Instruction Manual

Starting the Preparation Process.....35
Stopping the Process35
Spin Function36

4. Operating LaboForce-100

Changing the Specimen Holder / Specimen Mover Plate37
Manual Preparation.....37
Stopping the Process38

**Getting Acquainted with
LaboForce-100**

LaboForce-100 mounted on
LaboPol-30 (accessory):

Take a moment to familiarise yourself with the location and names of
the LaboForce-100 components.



- ① Control Panel
- ② LED lights (not shown)
- ③ Specimen mover head
- ④ Button for release of specimen holder/ mover plate
- ⑤ Dosing block with nozzles
- ⑥ Emergency stop
- ⑦ LaboDoser-100 (accessory)

Rear view

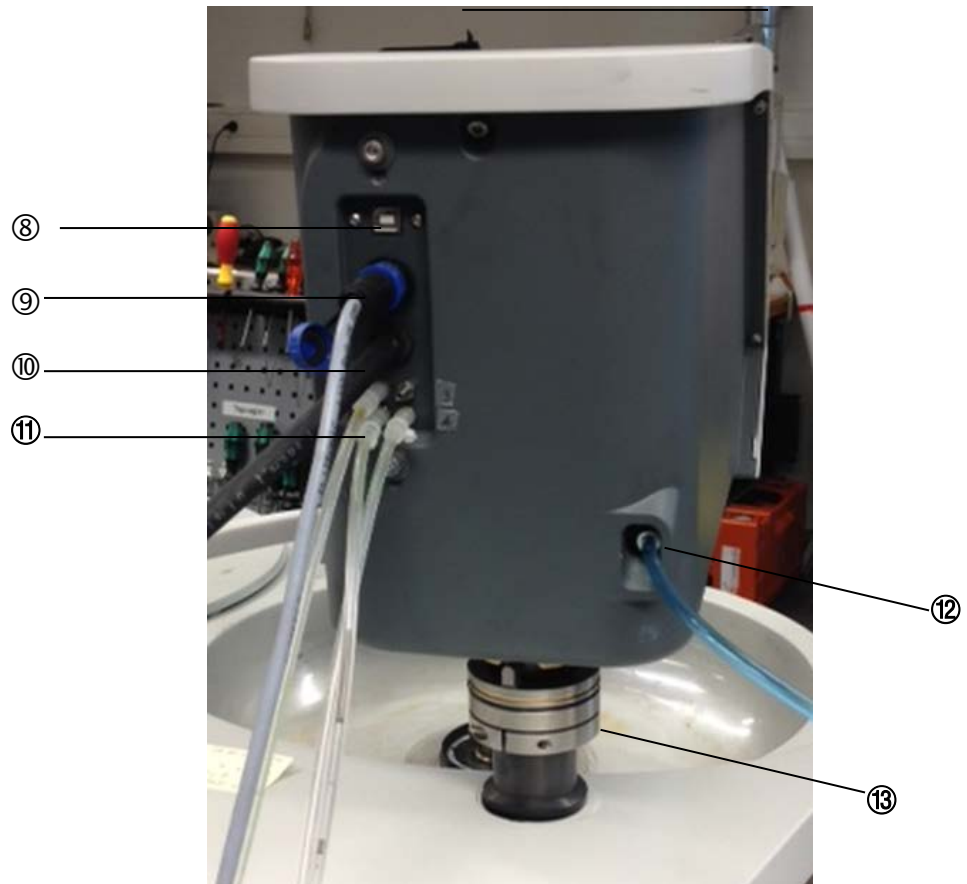

- ⑧ USB connection, for service purposes
- ⑨ Socket for LaboDoser-100 (accessory)
- ⑩ Power cable
- ⑪ Supply tubes from LaboDoser-100 (accessory)
- ⑫ Compressed air inlet
- ⑬ Adjustment ring

Mounting LaboForce-100

Note:

Do Not use the Turn/ Push knob to move LaboForce-100.

- Lead the LaboForce-100 supporting column down into the support hole.
- Tighten the 2 fastening screws.

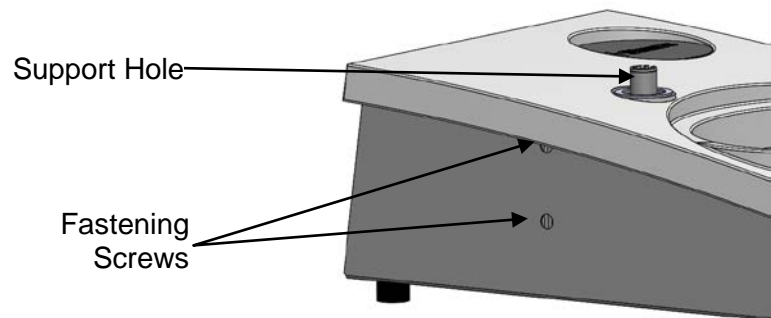

Electrical Connection

The cable attached to LaboForce-100 provides both a 24V power supply to the LaboForce-100 and a data bus, which enables the LaboPol and LaboForce-100 to communicate

- Switch LaboPol off.
- Connect the cable from LaboForce-100 to the Sample Mover connector on the rear of the LaboPol.

Compressed Air Connections

To connect compressed air:

- Mount the quick coupling on the compressed air hose and secure it with the hose clamp supplied.
- Connect the air inlet hose to the quick coupling and fit the other end into the compressed air inlet on LaboForce-100.

IMPORTANT

The air pressure must be between 6 bar (87 psi) and 9.9 bar (144 psi).

Note:

LaboForce-100 requires a continuous flow of compressed air through the regulator valve – a faint hissing sound does not mean that there is an air leak.

Emptying the Water / Oil Filter

LaboForce-100 is fitted with a water / oil filter that removes excessive amounts of these substances from the compressed air supply. As a result of this, it is necessary to empty the filter periodically:

- Locate the release outlet valve at the bottom of the LaboForce-100 head.
- Hold a cloth under the filter to retain any water released and press the release valve.

Release Outlet Valve

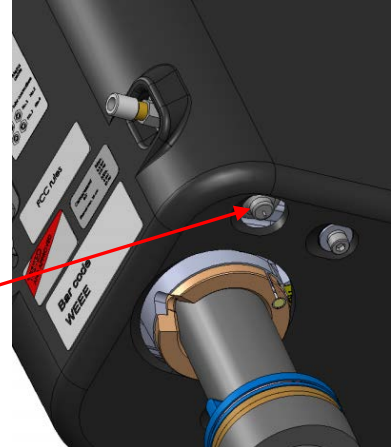

Inserting Specimen Holders or Specimen Mover Plates

LaboForce-100 can be used with either specimen mover plates for single specimens or specimen holders.

Inserting a Specimen Holder

- Press the Raise/Lower \blacklozenge key to ensure that the head is fully raised.
- Push the black button on the head.
- Insert the specimen holder and rotate it until the three pins are aligned and then push the holder upwards until it locks in position.
- Release the black button on the head and ensure that the specimen holder is securely fixed.

WARNING!

When working with specimen holders make sure that the screws clamping the specimens do not stick out of the specimen holder.
Use different length of screws for specimens with different diameters.

NOTE!

Max. height of specimens in the specimen holder is 32 mm.
Otherwise the specimen holder cannot be placed in the head.

Inserting a Specimen Mover Plate

- Use the Raise/Lower \blacklozenge key to ensure that head is fully raised.
- Push the black button on the head.
Insert the specimen mover plate and rotate it until the three pins are aligned and then push the specimen mover plate upwards until it locks in position.
- Release the black button on the head and ensure that the specimen mover plate is securely fixed.

Lowering the Specimen Mover Head

- Press the Raise/Lower \blacklozenge key to lower the specimen mover head into position ready for preparation.
The distance between the preparation disc and the specimen mover plate should be about 3 mm.
For adjusting the distance please see: [Adjusting the Specimen Mover Plate Height](#).

Adjusting the Specimen Mover Position

Height of Specimen Mover

With a specimen mover plate mounted.

- Place a preparation surface on the MD-Disc.
Select the 'thickest' preparation surface that is to be used.
Usually, this will be a SiC grinding paper on an MD-Gekko.
- Place the Spacing disc (supplied) on the preparation surface.

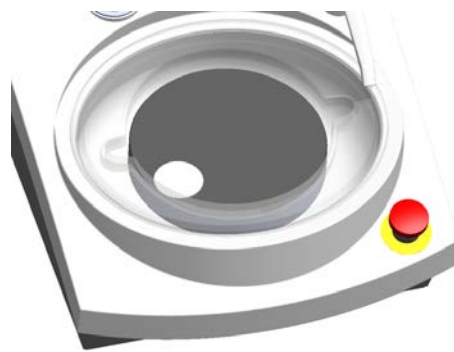

- Support the LaboForce-100 head and loosen the screw in the Adjustment ring.

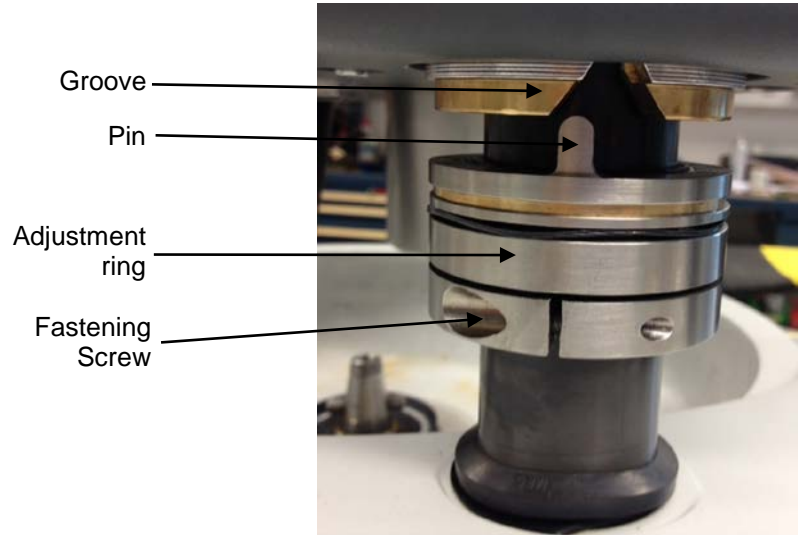

- Press the Raise/Lower \blacklozenge key to lower the specimen mover head (An error message will appear as the specimen mover head is not in contact with the Adjustment ring).
- Move the Adjustment ring up until the pin slots into the V-shaped groove on the LaboForce-100 cabinet.
- Tighten the adjustment ring to fix in this position.
- Press Enter to clear the error message.
- Press the Raise/Lower \blacklozenge key to raise the specimen mover head

*Adjusting the Horizontal Position
of the Specimen Holder / Mover
Plate*

With MD-Disc

With a specimen holder / mover plate mounted.

- Press the Raise/Lower \blacktriangle key to lower the specimen mover head.
- Loosen the 2 fastening screws holding the LaboForce-100 supporting column.
- Move the LaboForce head to the right.
The specimen holder / mover plate should be positioned to allow the specimen to run 3 – 4 mm over the edge of the preparation disc. (see illustration).

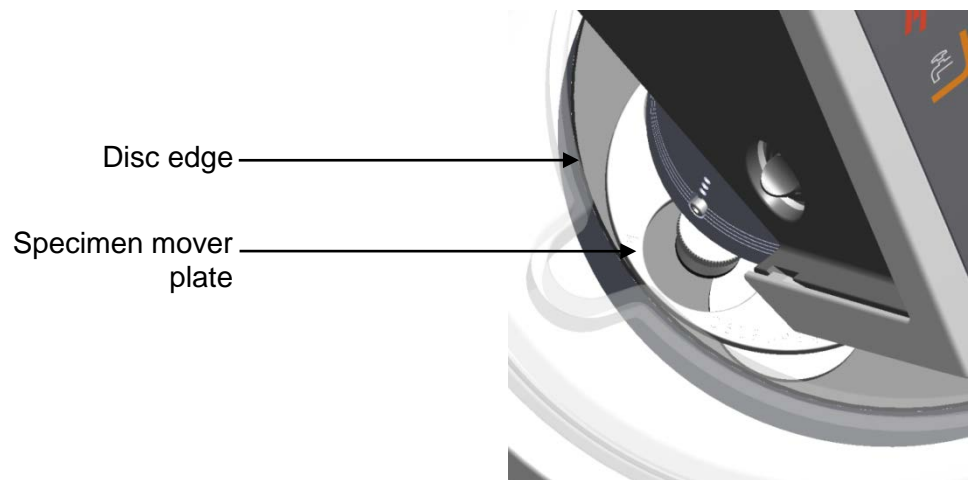

Important

The LaboForce-100 supporting column can only be turned slightly.
Do not force.

- Firmly tighten the 2 fastening screws to secure the supporting column in position.

IMPORTANT

Having adjusted the position, tighten the screws **firmly**.
The supporting column will now remain in position.

- Cover the holes with the two caps (supplied)

With Wet Grinding Disc

- Move the LaboForce head to the right.
The specimen holder / mover plate should be positioned 2 – 3 mm from the metal ring. (see illustration).

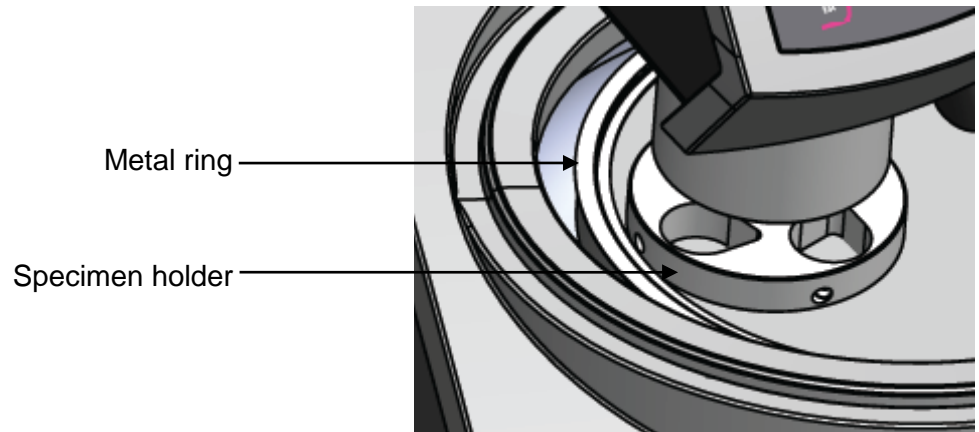

Important

The LaboForce-100 supporting column can only be turned slightly.
Do not force.

- Firmly tighten the 2 fastening screws to secure the supporting column in position.

IMPORTANT

Having adjusted the position, tighten the screws **firmly**.
The supporting column will now remain in position.

- Cover the holes with the two caps (supplied)

LaboDoser-100 with
LaboForce-100

See [Connecting a LaboDoser-100](#) on page 12.

LaboDoser-10 with
LaboForce-100

A Table Stand (Cat nr. 06376904) is required for using a LaboDoser-10 drip lubricator with a LaboForce-100 specimen mover.



2. Connecting a LaboDoser-100

Checking the Contents of the Packing Box

In the packing box you should find the following parts:

- 1 LaboDoser-100
- 1 Dosing bottle box with bottles and built-in pumps
- 1 Set of tubes (4 long, 4 short)
- 1 Spiral hose (to house tubes)
- 1 Set of Instruction Manuals

Mounting the Dosing Modules

- Position LaboDoser-100 next to LaboPol.
- Fill the bottles with Suspension/ Lubricant.
(Or screw the bottle caps with fitted tubes onto 500 ml Struers Suspension/ Lubricant bottles).
- Connect the bottles to the pumps (marked IN) using the short pieces of tube.
- Fit the long pieces of tube onto the rear of LaboForce-100 then connect to the pumps (marked OUT).
The pumps and the connections on the rear of LaboForce-100 are numbered to help connect the tubes to the correct pump.

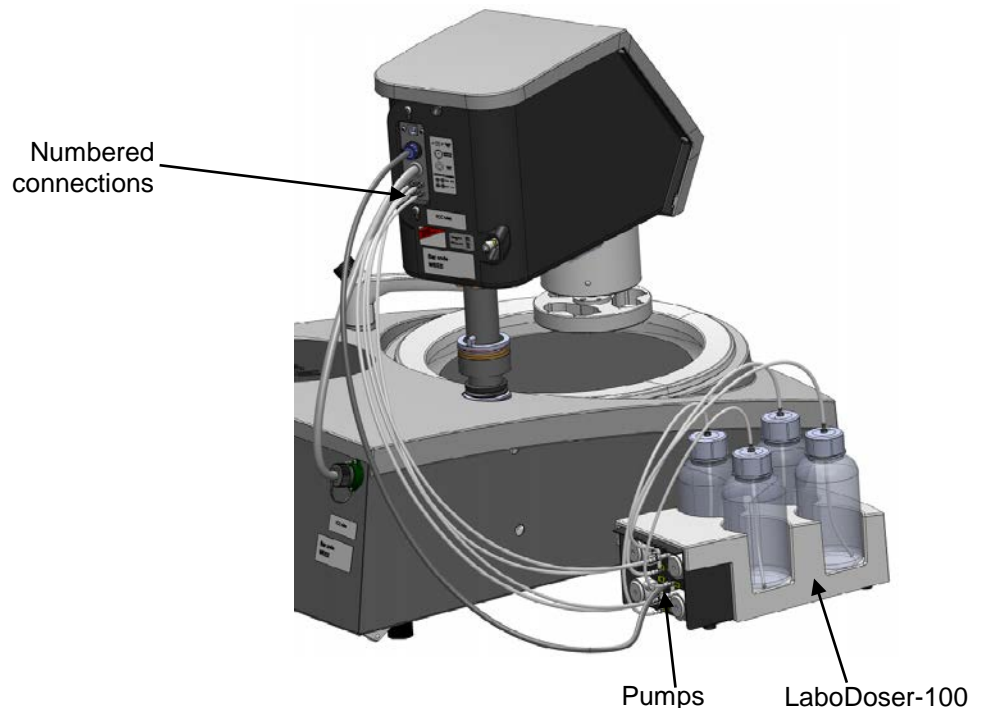

LaboForce-100
LaboDoser-100
Instruction Manual

- Place the section of spiral hose around the tubes.
- Make sure that the tubes are not taut, so that the LaboForce-100 head can be turned freely.

Note:

LaboDoser-100 is not designed for use with
Oxide Polishing suspensions.
Use a LaboDoser-10 if Oxide Polishing is required.

3. Basic Operation of LaboForce-100







LaboForce-100 Control Panel

The LaboForce-100 control Panel is used to operate the LaboPol machine.

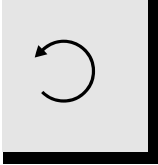

*LaboForce-100
LaboDoser-100
Instruction Manual*

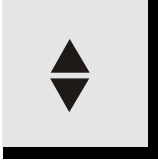
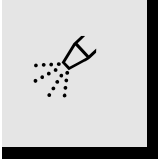
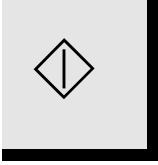
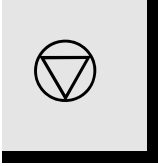
Front Panel Controls

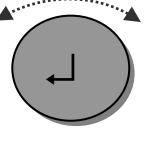
	Key	Function		Key	Function
FUNCTION KEY		Controls for various purposes. See the bottom line of the individual screens.	WATER		Manual override - push button to apply water (applies water when no process is running). Push button again to stop applying water (water will automatically switch off after 5 min.)
DISC ROTATION		Starts rotation of the disc. (Spin-Function)	ABRASIVE		Only active when dosing units are installed. Manual override – push button to apply diamond suspension from the doser bottle.
LOWER/RAISE		Lowers & raises the specimen mover head when preparing single specimens or when adjusting positions of specimen mover plate or specimen holder.	LUBRICANT		Only active when dosing units are installed. Manual override – push button to apply lubricant from the doser bottle.
			START		Starts the preparation process.
			STOP		Stops the preparation process.
ESC		Returns to the Main Menu or aborts functions/changes.	Turn/Push Knob		Used for entering and changing steps and parameters. Combined cursor and enter key. Enables selected parameter values to be activated for editing. Saves the edited parameter values. Toggles when only 2 options available.

Reading the Display

The display on the front panel provides different levels of status information. For example, when the machine is switched on using the Mains switch located at the rear of the machine, the display informs you about the physical configuration of the LaboForce-100 and the version of software that is installed:



When operating the LaboForce-100, this display is the user-interface to LaboForce-100's software.

The display is primarily divided into 2 areas. The position of these areas and the information they contain are explained in the illustration below, which uses the *Options* menu as an example:

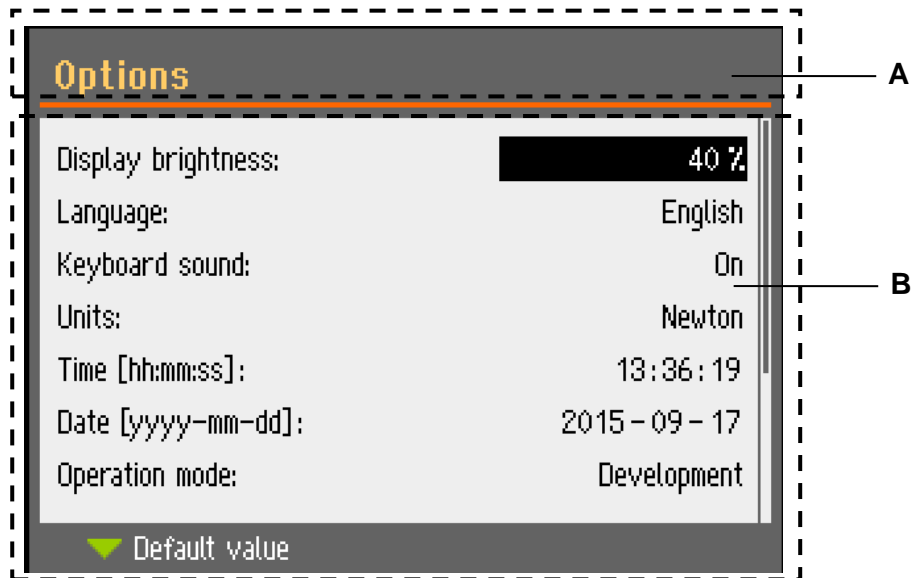

- A** Heading: this is a navigational aid, telling you where you are in the software's hierarchy.
- B** Information fields: these will be either numerical values or text fields, providing information associated with the process shown in the heading. The inverted text shows the cursor position.

Manoeuvring in the Menu Structure

To select items in the menu:



Turn knob to select a menu, method group or a parameter.



Push knob to open or activate the selection.

ESC Press **Esc** to return to the Main menu.



Tip:

To return to the last method that was active, press ESC from the Main Menu.



Software Settings

When switching LaboForce-100 on for the first time, the *Select language* screen will appear (to change the language after this, refer to “*Changing the Language*”).



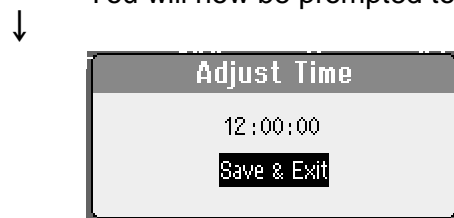



- ↓
-  Turn knob to select the language you prefer.
-  Push knob to accept the language.
- You will now be prompted to set the time.

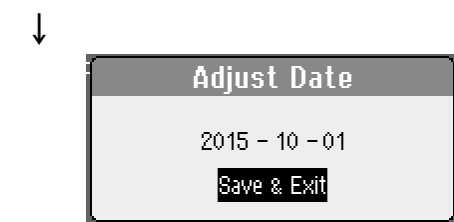

- ↓
-  Turn knob to select and to adjust the settings.
-  Push knob to accept the settings.
- You will now be prompted to set the date.





- ↓
-  Turn knob to select and to adjust the settings.

-  Push knob to accept the settings.
-  When Time and Date have been set, turn knob to select *Save and Exit*.
-  Push knob to *Save and Exit* (Save the settings and return to the *Main menu*).
The *Main menu* now appears in the language you have chosen.

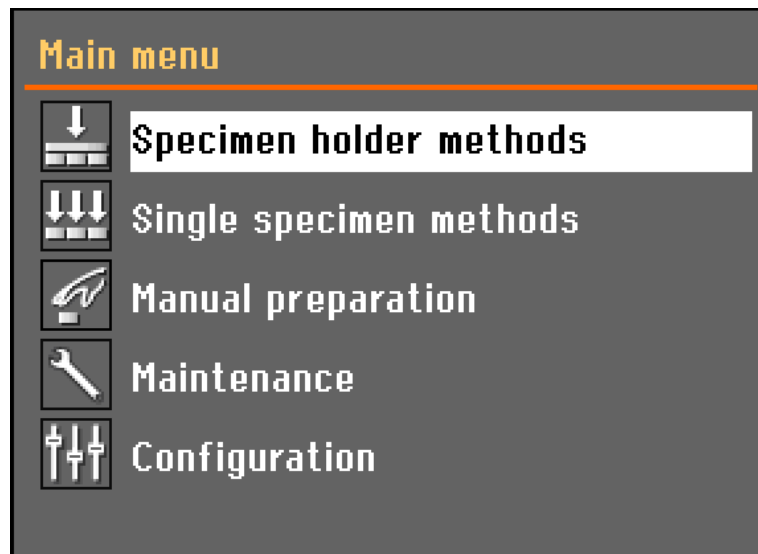



During normal operation, immediately after start up, where the splash screen is displayed, the software goes to the screen that was used before the machine was switched off. Thus you can continue exactly where you left last time the machine was used.
To go to the *Main menu*, use the **Esc** key. The *Main Menu* is the highest level in the menu structure. From this menu, you can enter all the other menus.

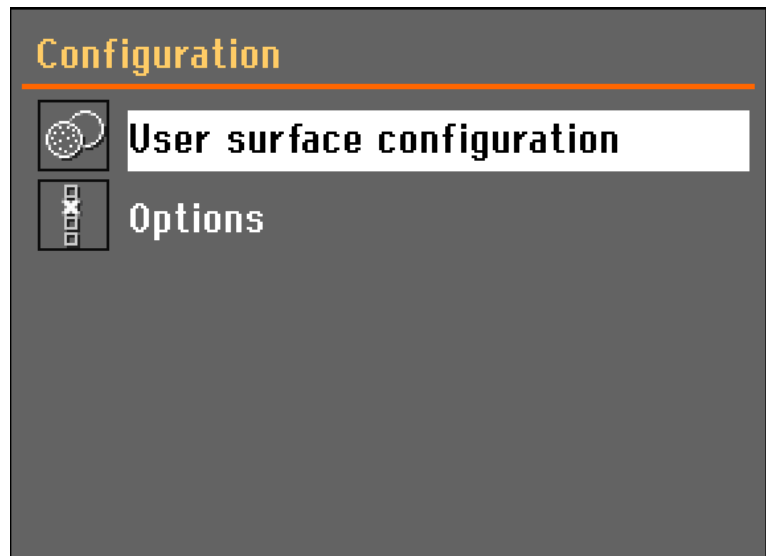

Changing the Language

-  Turn the knob to select *Configuration*.
-  Push knob to activate the *Configuration Menu*.
-  Turn the knob to select *Options*



-  Push knob to activate the *Options Menu*.
-  Turn knob to select *Language*.
-  Push knob to activate the *Select language* pop-up menu.
-  Turn knob to select the language you prefer.



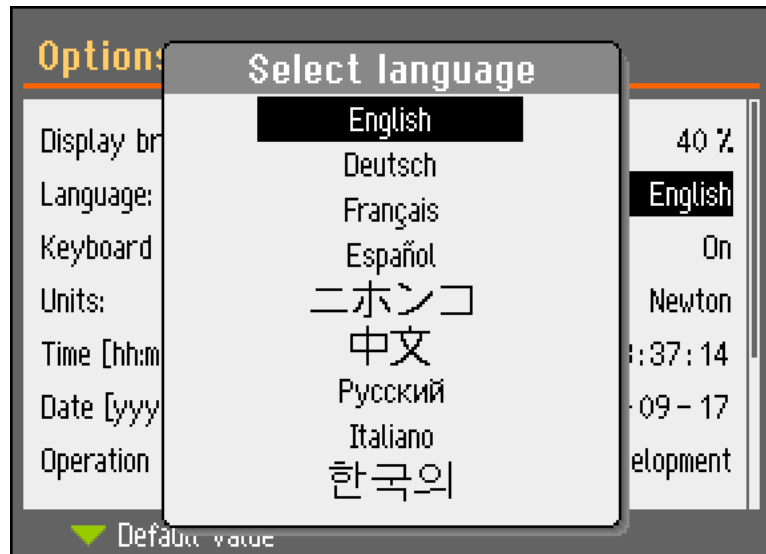

Push knob to accept the language.

The *Configuration* menu now appears in the language you have chosen.

Check if there are any other settings that need changing in the *Options* menu. If not, Push **ESC** to return to the *Configuration* menu.

Otherwise use the Turn/Push knob to select and change the required parameters.

Editing Numeric Values



Turn knob to select the value to be changed, e.g. *Display brightness*:

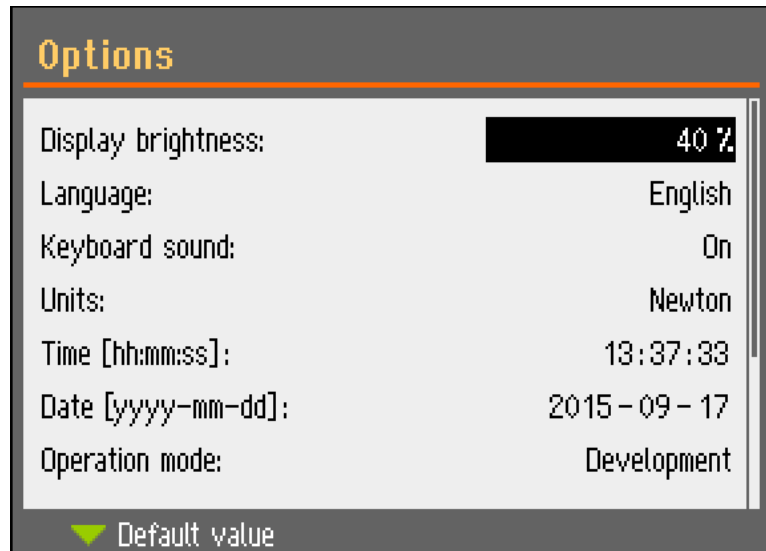

Push knob to edit the value.



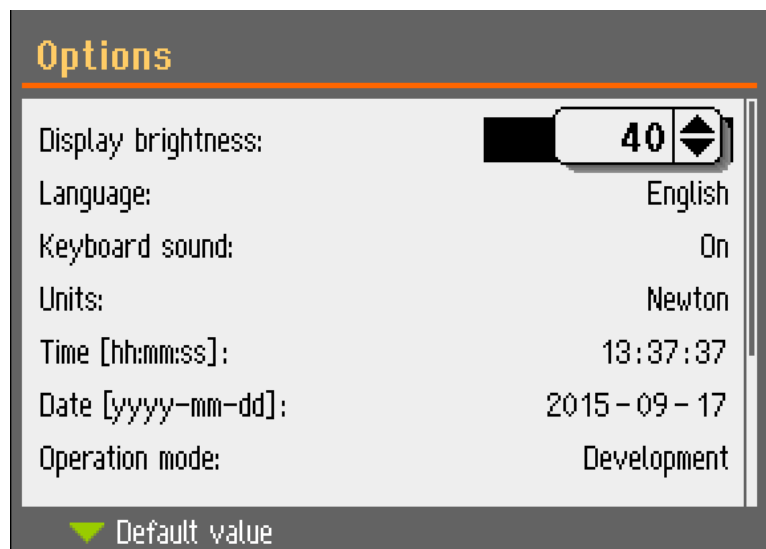

A scroll box appears around the value.



Note:

If there are only two options, the popup box is not displayed. Pressing the knob (Enter) will toggle between the 2 options.

 Turn knob to increase or decrease the numeric value (or to toggle between the two options).

↓
 Push knob to accept the new value. (Pressing **Esc**, aborts the changes, preserving the original value.)

Editing Alphanumeric Values

 Turn knob to select the text value to be changed, e.g. *Keyboard sound*:

↓

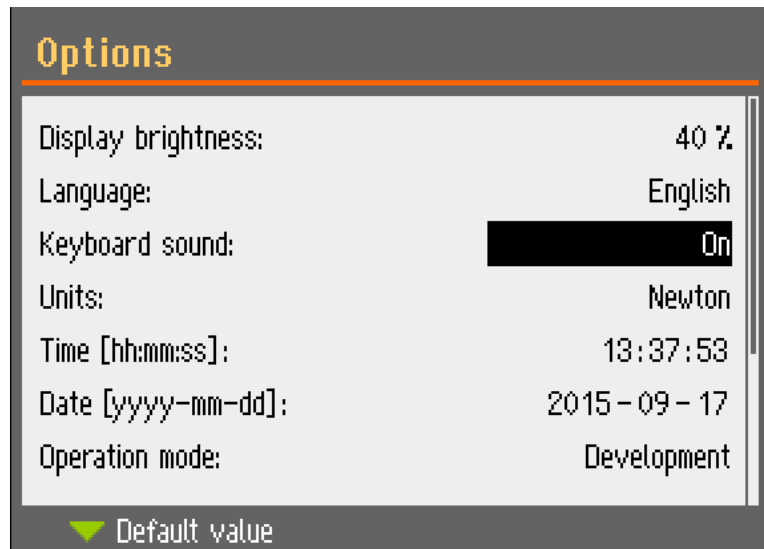

↓

 Push knob to toggle between the 2 options.

↓

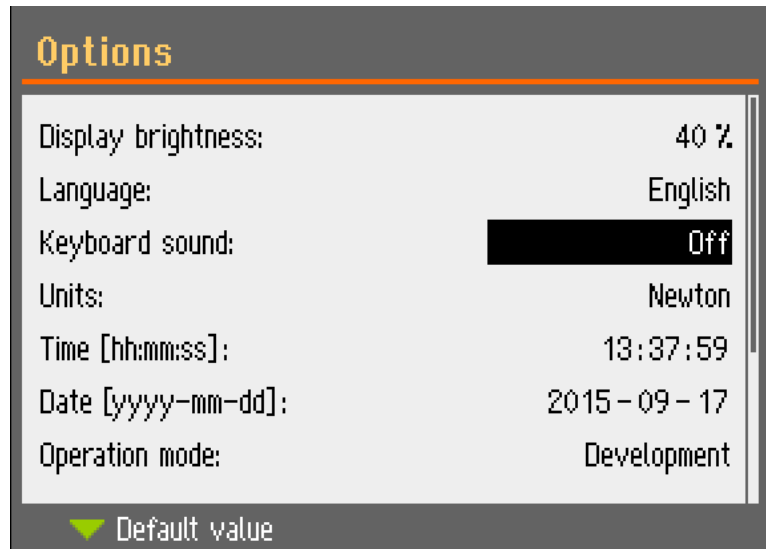

Note:

If there are more than two options, a popup box is displayed. Turn knob to select the correct option.

Press **Esc** to accept the option and return to the previous menu



Or turn knob to select and edit other options in the menu.

Operation Mode

In *Operation mode* 3 different user levels can be set.

- Production:** Methods: can be selected and viewed
Options: some options can be edited
- Development:** Methods: can be selected, viewed and edited
Options: some options can be edited
- Configuration:** Methods: can be selected, viewed and edited and bottles can be configured.
Options: all options can be edited

Changing Operation Mode

To change the operation mode, go to the *Configuration* menu and then the *Options* menu. Select **Operation mode** to get access to the *Operation mode* menu.

 Push knob to select **Pass code**.

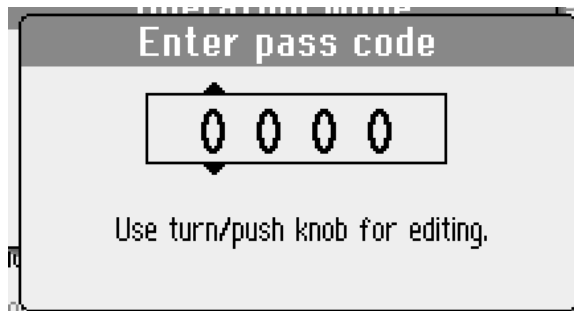

Use the Turn/ Push knob to enter the current pass code (The default pass code is '2750'.):

- Turn knob to change the digits
- Press knob to enter the pass code.

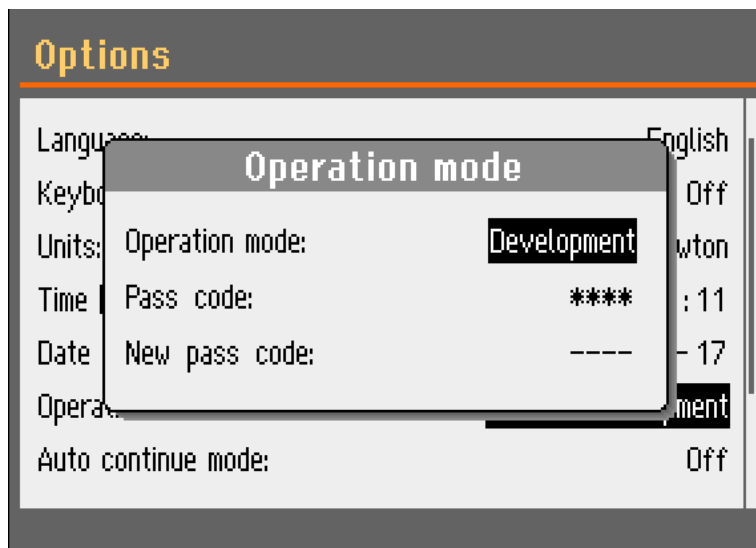



Push knob to select **Configuration**.

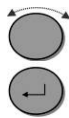
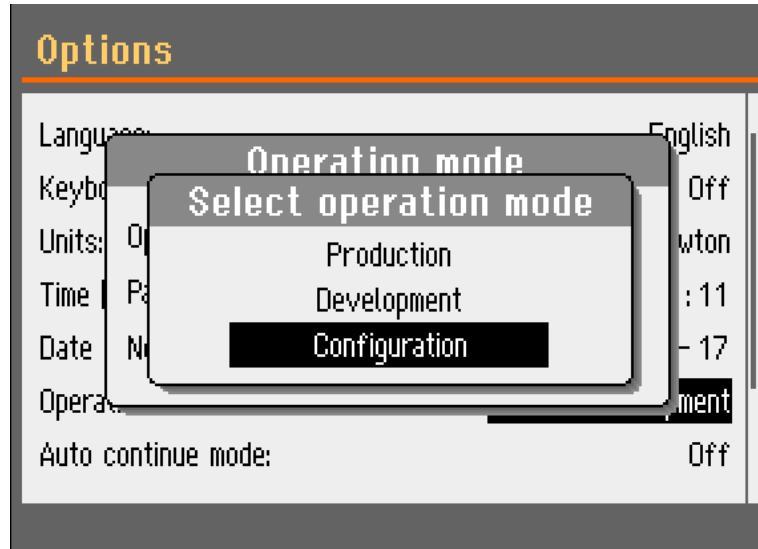

Select the desired operation mode and push knob to confirm.

New Pass Code

A New pass code can also be selected from the *Operation mode* menu.

Important!

Remember to make a note of the new Pass code as settings can no longer be changed without the Pass code.

User Surfaces

Up to 10 User Surfaces can be defined and saved.



Turn the knob to select *Configuration*.



Push knob to activate the *Configuration Menu*.



Turn the knob to select *User surface configuration*

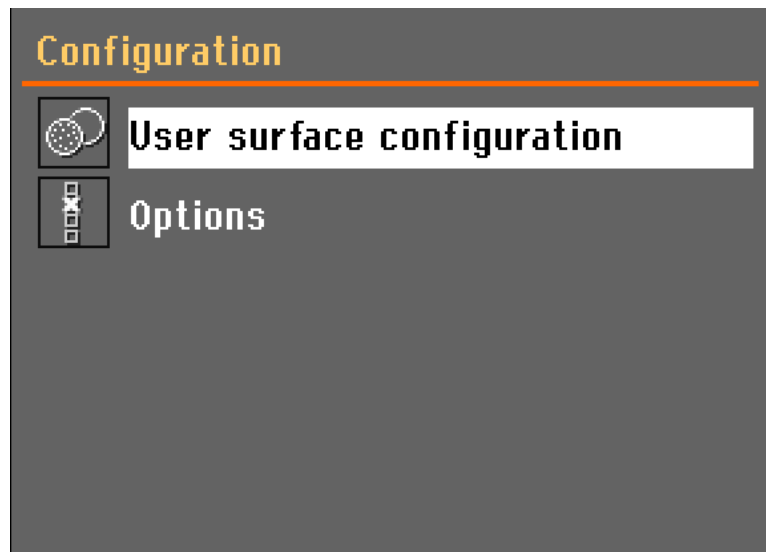

Push knob to activate the *User surface configuration* menu.

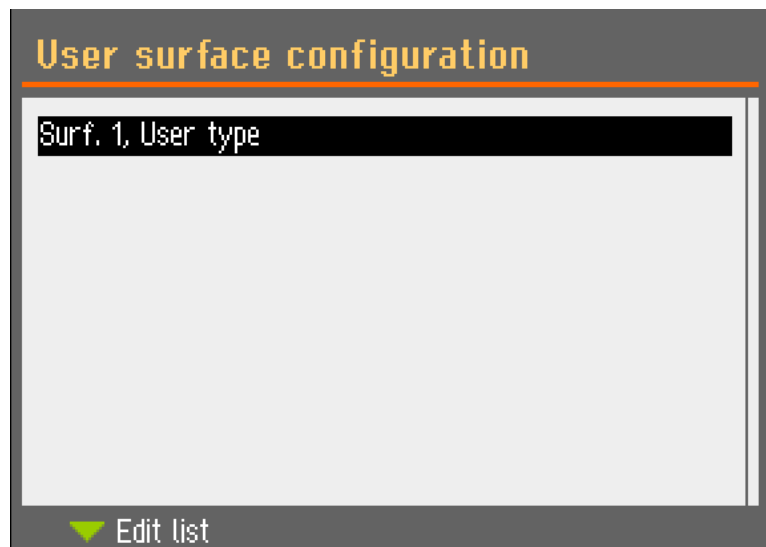



F1 Press F1 to rename the surface or to enter a new surface.

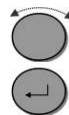
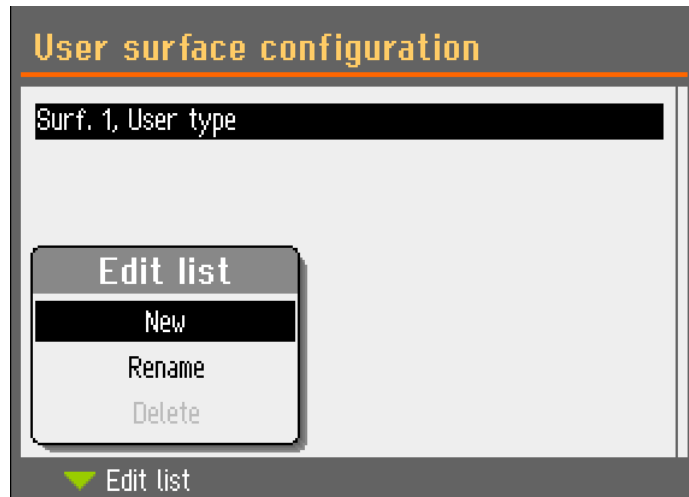

Use knob to activate the Text Editor menu.



Selecting a Preparation Mode

Three different preparation modes can be selected

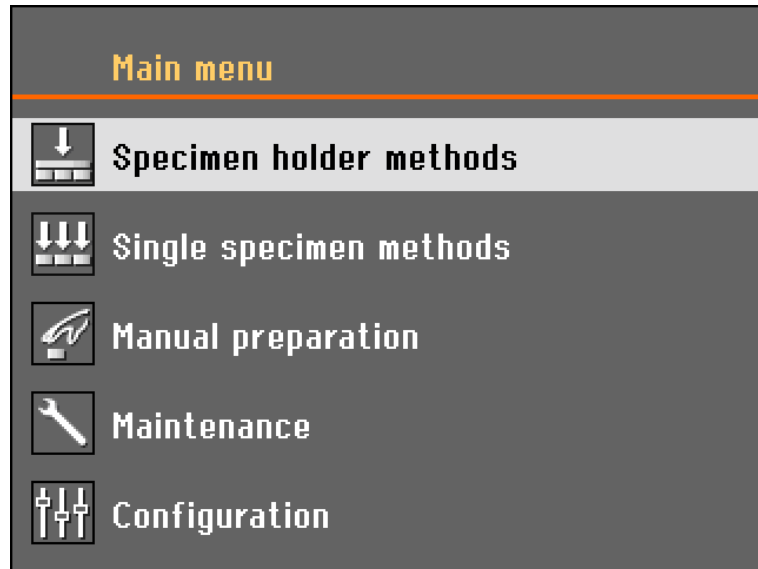

- Specimens can be clamped in specimen holders and prepared
- Specimens are prepared as single specimens
- Specimens can be prepared manually

Select the appropriate preparation mode by turning the knob and activate the selection by pushing the knob.

The first screen displays the Methods.
On a new machine only one method is shown.

The contents of the Methods are identical, no matter if *Specimen holder methods* or *Single specimen methods* is selected.

A method created in one selection is automatically created in the other selection as well.

All method parameters are exactly the same when a method is created initially, except for the force. The relation between single specimen force and specimen holder force is 1 to 6, i.e. 30 N in single specimen mode will be 180 N in specimen holder mode and vice versa.

However, when a method parameter such as time is changed later on, the other method will **not** be updated with the new values. This will allow for individual modifications due to specimen size and/or number.

NB!

If a preparation surface or suspension is changed in a method, this **will** be reflected in the other method.

Selecting a Preparation Method



Turn knob to select either *Specimen holder methods* or *Single specimen methods*.



Push knob to open the group view.

Important!

A small icon in the top right corner shows if *Specimen holder methods* or *Single specimen methods* are selected.



Indicates *Specimen holder methods*



Indicates *Single specimen methods*

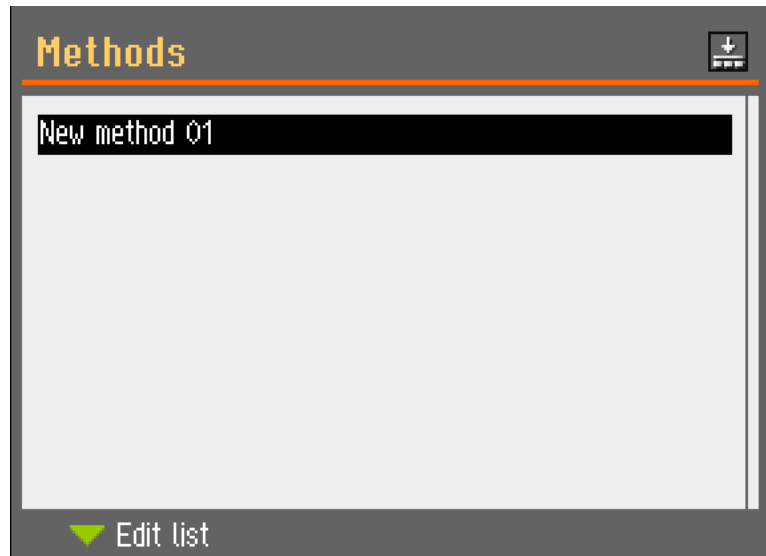

Turn knob to select a Method.



Push knob to open the step view.



The screenshot shows a screen titled "My method 01" displaying a table of steps. At the bottom, there is a green downward-pointing triangle icon followed by the text "Edit list".

	Surface	Susp.	Lub.	Time
1	SiC-Paper #320	-	Water	2:00 min
2	MD-Largo	1	2	3:00 min
3	MD-Dac	1	2	3:00 min
4	MD-Nap	1	-	1:00 min

Editing a Preparation Method

All parameters can be changed to optimise the preparation method.

Use the knob to select a *Method*.



Push knob to open the method and display the steps.



My method 01			
Surface	Susp.	Lub.	Time
1 SiC-Paper #320	-	Water	2:00 min
2 MD-Largo	1	2	3:00 min
3 MD-Dac	1	2	3:00 min
4 MD-Nap	1	-	1:00 min

▼ Edit list



Push knob to display the parameters.



My method 01 → Step 1		
	SiC-Paper #320	
	None	
	Water	On
	240 _N	2:00 min
	300 rpm	150 rpm
Set disc motor speed		

Default settings for a typical preparation process are already selected. e.g.:

- Step No. 1 is designed to be a plane grinding step.
- Step No. 2 is designed to be a fine grinding step.
- Step No. 3 is designed to be a polishing step.

Change the settings to optimise the preparation method.

↓ Use the knob to select the parameter to be edited e.g. Force.

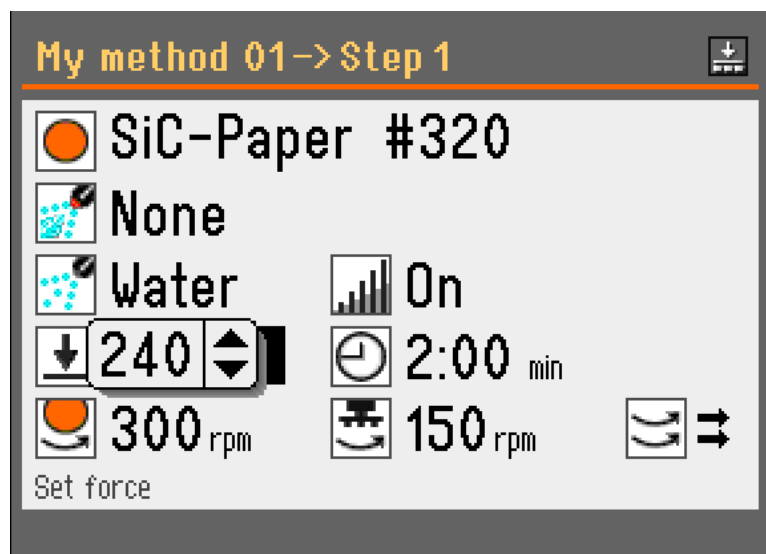

↓ Use the knob to edit the parameter/ value and push the knob to confirm the new value. (Pressing **Esc**, aborts the changes, preserving the original value.)

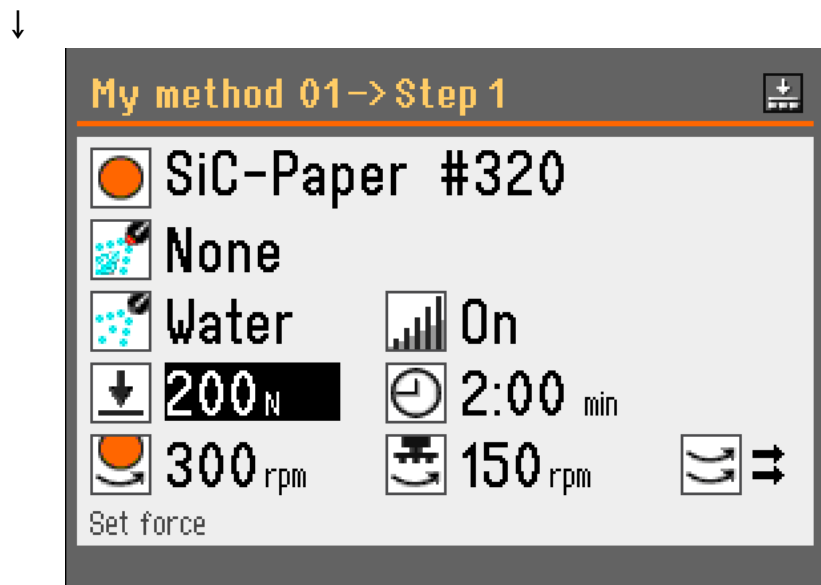

To add new steps:

F1 Press **F1** to add or delete steps.

New steps are automatically added to the end of the list.
Modifications to the steps are saved automatically.
Methods can have up to 20 steps.
Up to 3 methods can be saved.

Renaming a Method

To rename a method:.

F1 Press **F1** to edit or delete Methods in the list.

Up to 3 methods can be saved in LaboForce-100.

Starting the Preparation Process

Once the desired method has been selected,

- Press Start  to start the preparation.

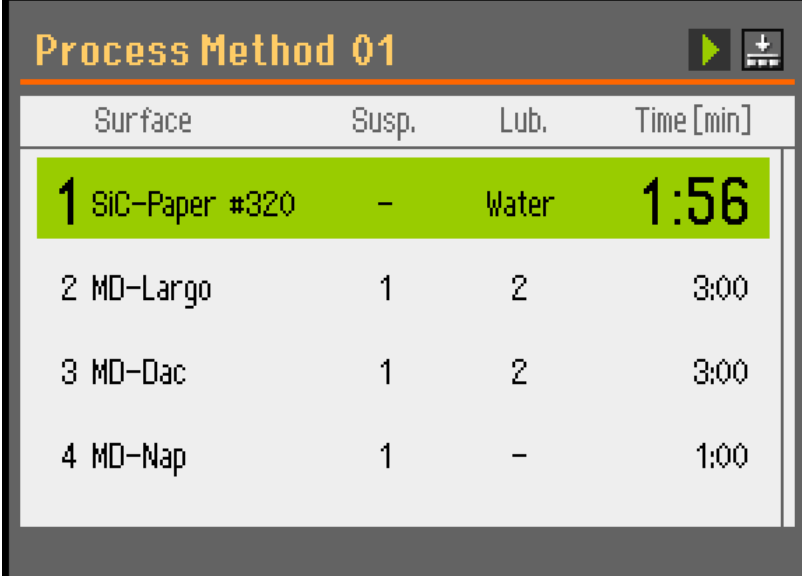

	Surface	Susp.	Lub.	Time [min]
1	SiC-Paper #320	-	Water	1:56
2	MD-Largo	1	2	3:00
3	MD-Dac	1	2	3:00
4	MD-Nap	1	-	1:00

Stopping the Process

The process stops automatically when the set preparation time has expired

- To stop the process before the set preparation time has expired, press .

The process will now be paused and the Pause icon  will appear :

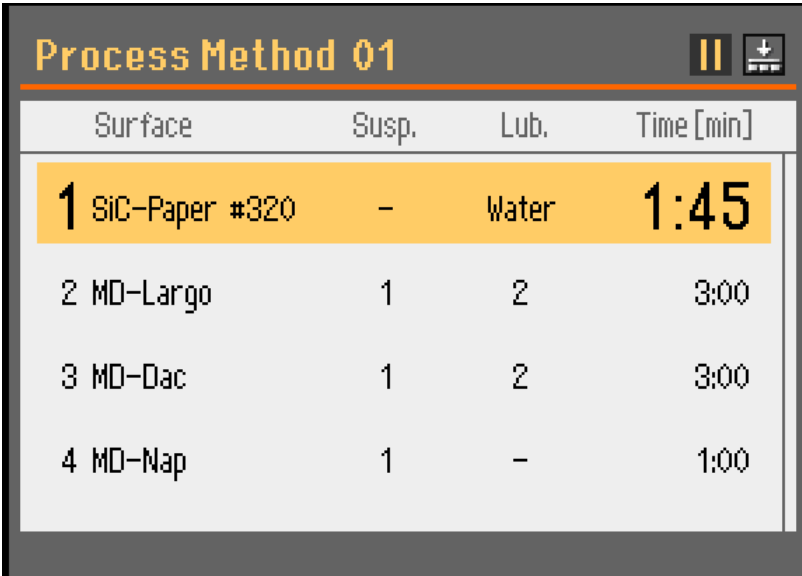

	Surface	Susp.	Lub.	Time [min]
1	SiC-Paper #320	-	Water	1:45
2	MD-Largo	1	2	3:00
3	MD-Dac	1	2	3:00
4	MD-Nap	1	-	1:00

- Press Start  to continue the preparation.

Or

- Press Stop  again, to abort the preparation.

Spin Function

After a grinding process has finished, the built-in Spin function can be used to rotate the preparation disc at high speed to remove water from the surface of the disc.

This function can be used to remove water from a MD-grinding disc or a SiC-paper before removing it, or to dry an MD-Disc or an MD-Chem cloth.

150 rpm

- Press the Disc key  to start the Spin function (150rpm).
- Press the Disc key again, to stop the Spin function.

600 rpm

- Press **and hold** the Disc key  to start the Spin function (600rpm).
- Release the Disc key to stop the Spin function.

4. Operating LaboForce-100

Changing the Specimen Holder / Specimen Mover Plate

If specimens of another diameter are to be prepared, a different specimen holder or specimen mover plate must be used. See [Inserting Specimen Holders or Specimen Mover Plates](#).

Manual Preparation

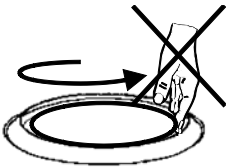

Warning!

While grinding manually, be careful not to touch the grinding disc. Do not attempt to collect a specimen from the tray while the disc is running. Whilst the disc is rotating, ensure hands are kept well clear of its periphery and out of the splash bowl.

If a specimen cannot be prepared using a standard specimen mover plate or specimen holder, it can be prepared manually.

- From the *Main menu*, select *Manual preparation*.

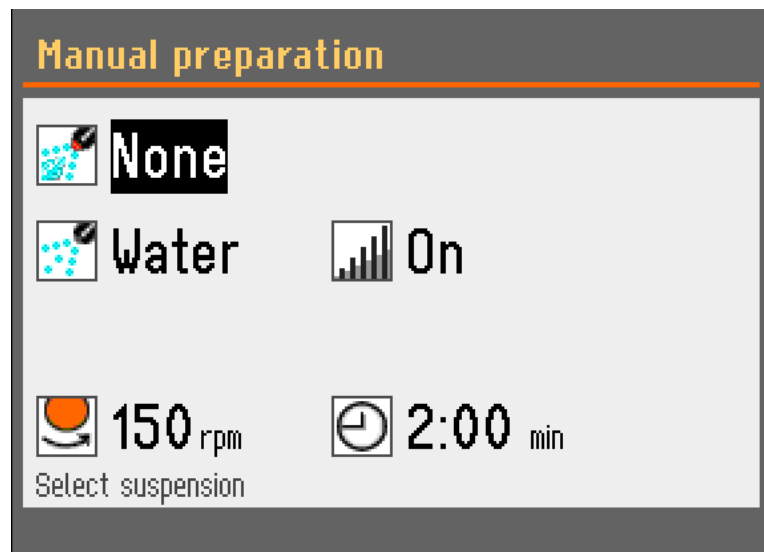

- Select the suspension bottle number and dosing level.
- Select the lubricant bottle number and pre-dosing and dosing level.
- Set the Speed and Time.

- Press Start ◊.
The disc will start turning at the pre-set speed and dosing will commence.

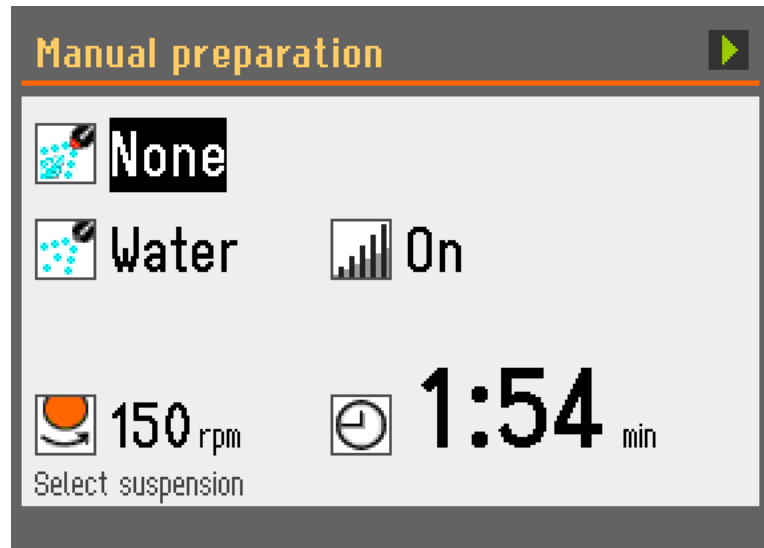

Stopping the Process

The disc and dosing will stop automatically when the pre-set time expires.

- To stop both the disc and the dosing before the time has expired, press Stop ⊘.

The process will now be paused and the Pause icon  will appear

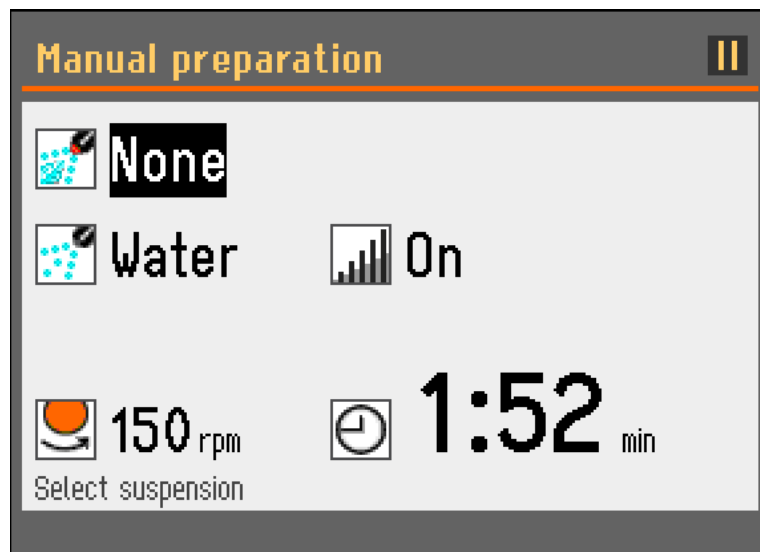

- Press Start ◊ to continue the preparation.
- Or
- Press Stop ⊘ to abort the preparation.

5. Maintenance

Daily

- Clean all accessible surfaces with a moist cloth.
- Check and refill the dosing bottles.

Tip:

Do not use a dry cloth as the surfaces are not scratch resistant.
Grease and oil can be removed with ethanol or isopropanol.

IMPORTANT

Never use acetone, benzol or similar solvents.

Weekly

- Clean painted surfaces and the control panel with a soft damp cloth and common household detergents.
- Clean the pressure feet and pistons applying the force on the specimens and specimen holder. (Select the *Maintenance* menu and *Cleaning of specimen mover head*).
- Press the release outlet valve to drain the water/oil filter (please see section on [Emptying the Water / Oil Filter](#)).

Yearly

Struers recommends that a regular service check be carried out every year.

- Contact Struers Service to service the machine.

Cleaning of Tubes

LaboForce-100 is equipped with an automatic cleaning function for flushing the tubes between the bottles and the dosing nozzles.

To clean the tubes:

- Go to the *Maintenance* menu and select *Cleaning of tubes* and select the tubes to clean.

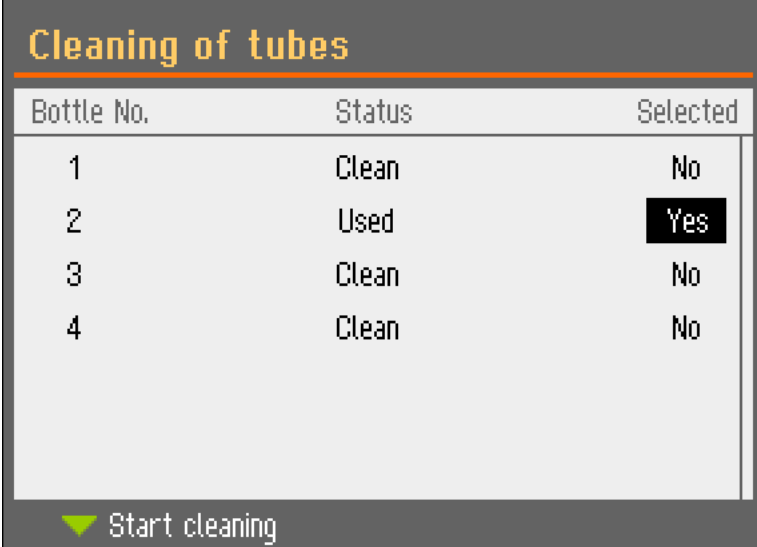

Bottle No.	Status	Selected
1	Clean	No
2	Used	Yes
3	Clean	No
4	Clean	No

▼ Start cleaning

- Press F1 to start the cleaning process.
- Follow the instructions on the screen to complete the operation.

Cleaning of Specimen Mover Head

LaboForce-100 is equipped with a function that allows you to clean the feet applying the force onto the specimens and also the lock that secures the specimen mover plate for single specimens.

To activate these functions:

- Go to the *Maintenance* menu and select *Cleaning of specimen mover head*.

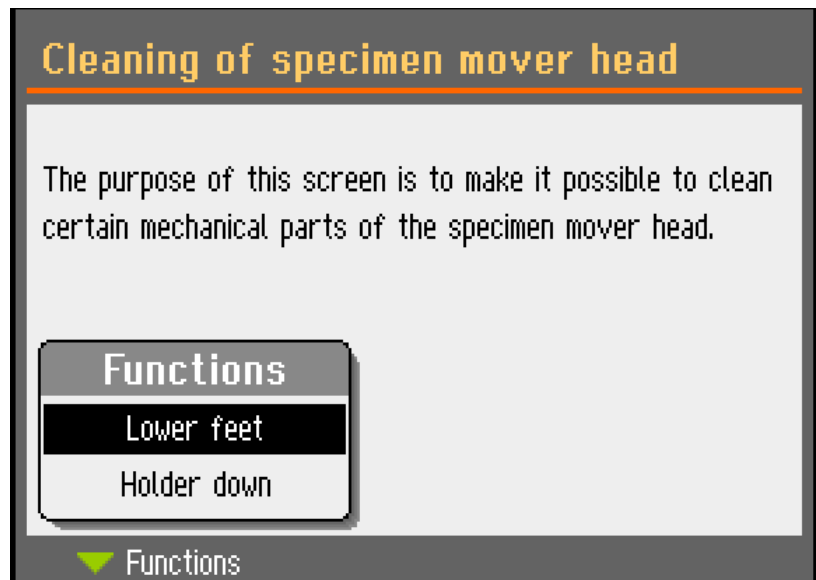

- Press F1 to activate either of the functions.
 - *Lower feet* the pistons can now be cleaned or lubricated.
 - *Raise feet* to move the feet back to operating position.
 - *Holder up* to move the Specimen mover head up for cleaning.
 - *Holder down* to move the Specimen mover head back to operating position.

IMPORTANT!

Never try to force any of the movements. If the components do not move as they should always contact the Struers technical service.

Reference Guide

Table of Contents	Page
1. Advanced Operation	
Configuration.....	43
Options menu.....	43
Auto continue mode	44
Recommendations for Grinding Single Specimens.....	45
2. Accessories and Consumables	46
3. Trouble-shooting	47
Error Messages.....	48
Messages	48
Errors.....	48
4. Maintenance	
Reset Configuration	53
Reset Configuration	53
Service Information	Error! Bookmark not defined.
5. Technical Data	54

1. Advanced Operation

Configuration

A number of different settings and parameters can be set or adjusted from the *Configuration* menu.

There are 2 under menus:

- Options
- User surface configuration

Options menu

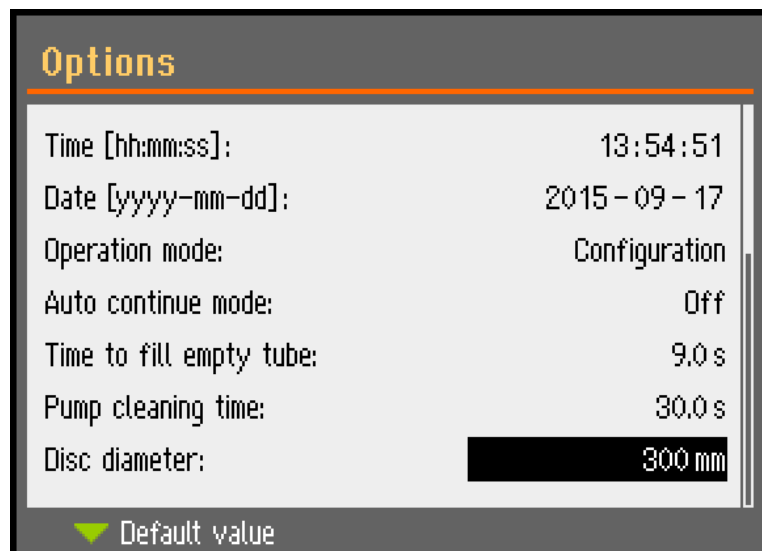
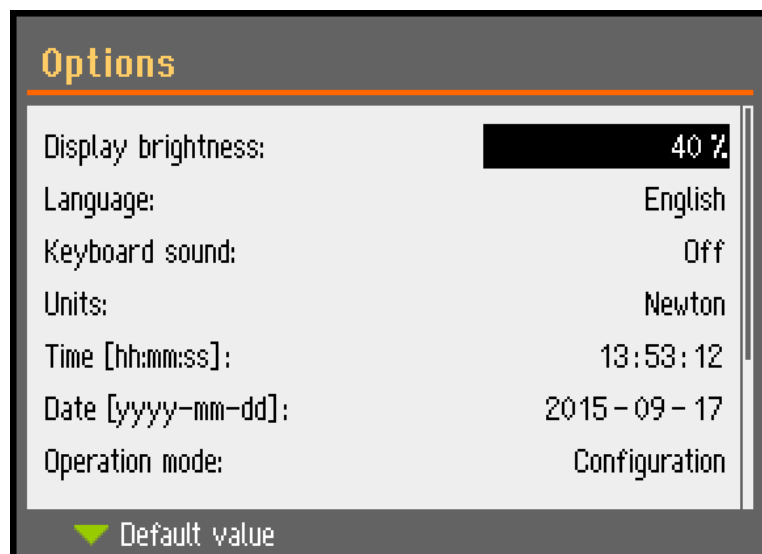

Default value:

To re-set the setting to default value, press the F1 key on the Control Panel.

Auto continue mode

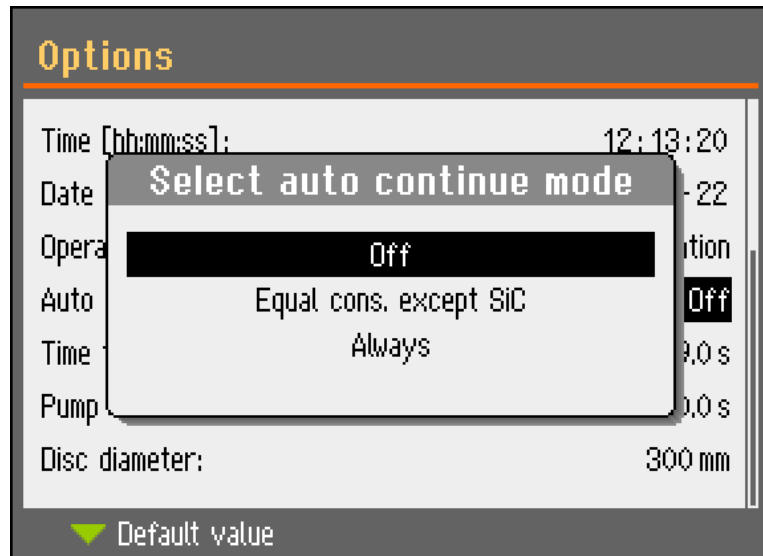

Auto continue mode can be set for LaboForce-100 to automatically continue to the next step in a method (as long as the consumables used are the same).

Equal cons. except SiC

LaboForce-100 will not proceed to the next step when grinding with SiC as the paper will need to be exchanged between the steps.

Recommendations for Grinding Single Specimens

Do not use plane grinding with coarse abrasives when preparing single specimens. It is normally not necessary, and the use of coarse abrasives can result in un-plane specimens.

If, for whatever reason, it is necessary to grind using coarse abrasive, the planeness may be improved using the following recommendations:

- The height of the specimen should be between 8 – 35 mm and not exceed $0.7 \times$ specimen diameter.
Example: A specimen with a diameter of 30 mm should not be higher than $30 \times 0.7 = 21$ mm.
- Use as small a grain size as possible.
- Use a mounting resin with a wear resistance similar to the specimens wear resistance.
- Use 150 rpm for both grinding disc and specimen mover.
(When using lower speeds decrease the speed on both the disc and the specimen mover).
- Use co-rotation.
(both the disc and the Specimen Mover Head rotate counter-clockwise).
- Use low force.
- Position specimen mover head of LaboForce-100 so that the specimens do *not* pass over the centre of the preparation disc.

2. Accessories and Consumables

LaboForce-100

Please refer to the [LaboSystem brochure](#) and the [Consumables Catalogue](#) for details of the range available.

Specimen Holders

Please refer to the [Struers Specimen Holders brochure](#) for details of the range available.

Remember...

Struers offers a comprehensive range of consumables for grinding and polishing.

The use of Struers consumables is recommended. Other products (e.g. coolants) may contain aggressive solvents, which dissolve e.g. rubber seals. The warranty may not cover damaged machine parts (e.g. seals and tubes), where the damage can be directly related to the use of non-Struers consumables.

3. Trouble-shooting

Error	Cause	Action
Specimen holder plate vibrates.	Specimen holder plate unbalanced. Specimen holder plate screws loose.	Replace specimen holder plate. Tighten specimen holder plate screws.
The preparation disc runs unevenly or stops.	Speed is lower than 300 rpm.	Increase speed to 300 rpm.
	Force too high.	Reduce the force.
The preparation disc stops.	Frequency inverter has stopped the equipment.	Switch the equipment off. Wait for a few minutes then Re-start. If error remains, contact Struers Service.
The column starts to turn.	Column screws loose.	Tighten the screws immediately.
Uneven specimens.	Specimens are wider than the radius of the preparation disc.	Use smaller specimens.

Error Messages

Error messages are divided into two classes:
 Messages and Errors

Messages





Messages are intended to inform the operator of the machine's progress and advise about minor operational errors.

Errors

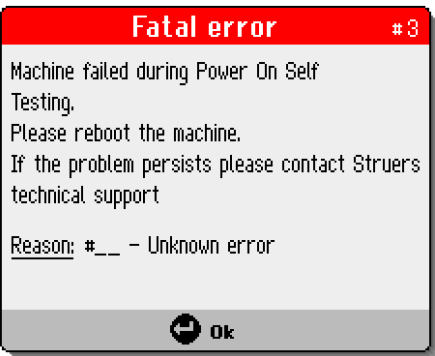
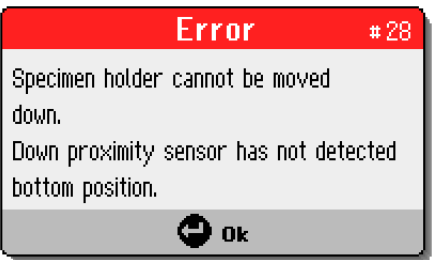
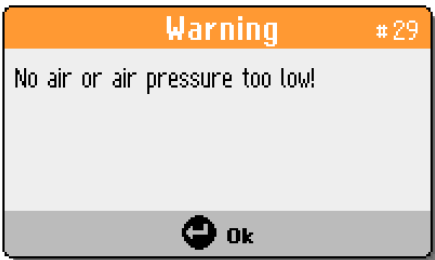
Errors must be rectified before operation can be continued.

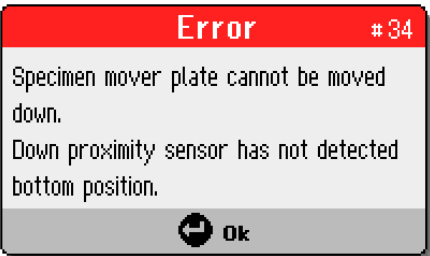
Press **ENTER** to acknowledge the error/message.

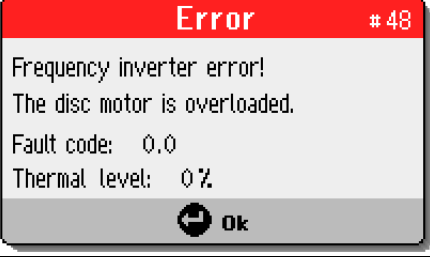
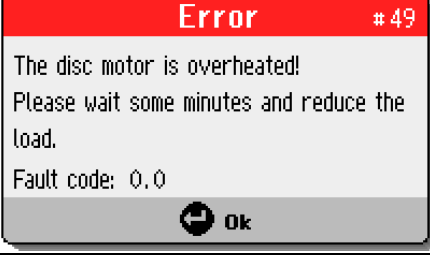
Error Message	#	Explanation	Action
	3	Failure of internal communication on Start-up.	If the <i>Reason</i> is the Struers Memory Module (SMM), remove and then re-insert the (SMM). Re-start. If error remains, contact Struers Service Please make a note of the <i>Reason</i> number.
	28		Check there are no obstacles preventing the movement of the specimen holder. Check the pneumatic system. If error remains, contact Struers Service.
	29	Pressure of the compressed air supply is too low.	Check the compressed air supply.

Error Message	#	Explanation	Action
 <p>Error #30 Pressure regulating error! Ok</p>	30	Pressure of the compressed air supply is too high/low.	Check the compressed air supply. Re-start. If error remains, contact Struers Service.
 <p>Error #34 Specimen mover plate cannot be moved down. Down proximity sensor has not detected bottom position. Ok</p>	34		Check there are no obstacles preventing the movement of the specimen mover plate. Check the pneumatic system. If error remains, contact Struers Service.
 <p>Error #46 Disc motor RPM's has not been reached. Ok</p>	46	Disc motor will not rotate or cannot reach the set RPM. Polishing process is paused.	Start the process again. If error remains, contact Struers Service.
 <p>Error #48 Frequency inverter error! The disc motor is overloaded. Fault code: 0,0 Thermal level: 0% Ok</p>	48		Wait for the disc motor to cool. Reduce the force and continue the preparation process.
 <p>Error #49 The disc motor is overheated! Please wait some minutes and reduce the load. Fault code: 0,0 Ok</p>	49		Wait for the disc motor to cool. Reduce the force and continue the preparation process.
 <p>Error #50 Frequency inverter fault! Fault code: 0,0 Ok</p>	50	An error in the frequency inverter is detected.	Re-start. If error remains, contact Struers Service. Please make a note of the <i>Fault code</i> .

Error Message	#	Explanation	Action
<p>Error #53 Specimen mover motor power supply out of range or missing! Ok</p>	53		Re-start. If error remains, contact Struers Service.
<p>Error #55 No communication to frequency inverter! Ok</p>	55		Re-start. If error remains, contact Struers Service.
<p>Warning #58 A bad electrical connection for the following output is detected: Ok</p>	58		Re-start. If error remains, contact Struers Service. Please make a note of the <i>output</i> named.
<p>Warning #59 Specimen holder motor overload, please reduce the force. Ok</p>	59		Reduce the force or/and increase the specimen RPMs. Start the process again. If error remains, contact Struers Service.
Message	#	Explanation	Action
<p>Information #26 Specimen mover plate not lowered! Ok</p>	26	The pneumatic head with specimen mover plate is not down when the process is started. Appears if method is started in single specimen mode (SS) and mover plate is not lowered.	Lower the pneumatic head. Start the process again.

4. Service

Service Information

LaboForce-100 offers extensive information about the conditions of all different components.

To reach this function:

- Go to the *Maintenance* menu and select: *Service information*.

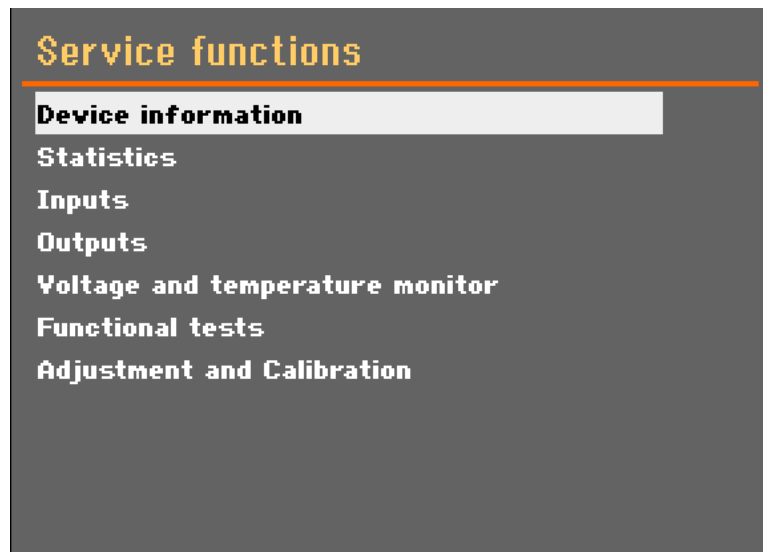

Various topics can be selected for information on the condition of the different components.

Service information can also be used in cooperation with Struers Service for remote diagnostics of the equipment.

Service information is read-only information, machine settings cannot be changed or modified.

NOTE:

The Service Information menus are in English only.
Using the same names/ terms is useful when communicating with your local Service Technician or the Struers Customer Service department.

Service Check

Struers recommends that a regular service check be carried out after every 1500 hours of use. Information on total operation time and servicing of the machine is displayed on the screen at start-up:



A pop-up message will appear after 1,500 hours operation time to alert the user that the recommended service interval has been exceeded.

- Contact Struers Service to service the machine.

Reset Configuration

It can become necessary to reset the configuration to the factory settings using the *Reset Configuration* menu.

- Go to the *Maintenance* menu and select: *Reset Configuration*.

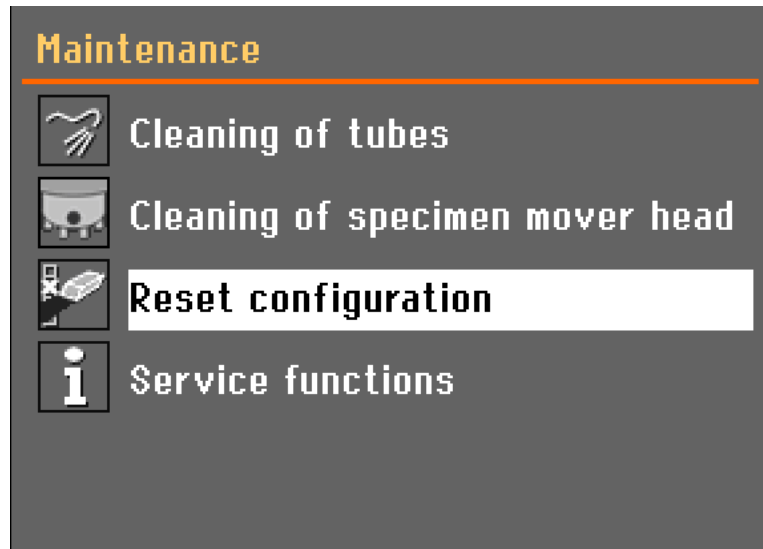

Reset Configuration

- Select *Reset configuration* to set all configuration parameters back to their default settings.
- Switch LaboForce-100 off, then on again and reconfigure the settings.

Tip!

It is advisable to make a note of your own customised settings before carrying out a *Reset configuration*.

5. Technical Data

Subject		Specifications
	Motor output	180 W
	Rotational speed	50-150 rpm at 50/60 Hz
	Rotational direction	Clockwise / Counter-clockwise
	Force, Individual specimens	10-50 N
	Force, Specimen holder	30-300N
Safety Standards	Please refer to the Declaration of Conformity	
Noise Level	57 dB (A) running at idle, at a distance of 0.25m/10" from the machine	
Power Supply	LaboForce-100 is connected directly to LaboPol-30 or LaboPol-60	
Software and electronics	Controls	Touch pad and push/turn knob
	Memory	FLASH-ROM / RAM / NV-RAM
	LC display	TFT-colour 320x240 dots with LED back light
Operating environment	Surrounding temperature	5-40°C / 41-104°F
	Humidity (Non condensing)	0-95% RH
Supply	Air inlet	6 mm/ 1/4" dia.
	Air pressure	6-9.9 bar / 87-143 psi
	Air quality	Recommended quality: ISO 8573-1, class 5.6.4.
Dimensions and Weight	Width	20.3 cm / 8"
	Depth	43.3 cm / 17.0"
	Height	57.4 cm / 22.6"
	Weight	20.5 kg / 45.2 lbs

English

Declaration of Conformity

Manufacturer

Struers ApS
 Pederstrupvej 84
 DK-2750 Ballerup, Denmark
 Telephone +45 44 600 800

Herewith declares that

<i>Name:</i>	LaboForce-50 /-100/-Mi
<i>Cat. No.:</i>	06356127 / 06366127 / 06386130
<i>Function:</i>	Specimen mover
<i>Type No.:</i>	635 / 636 / 638

fulfils all the relevant provisions of the:
**Machinery Directive
 2006/42/EC**

according to the following standard(s):
 EN ISO 12100:2010, EN 60204-1:2006/AC:2010.

and is in conformity with the:
**EMC Directive
 2014/30/EU**

according to the following standard(s):
 EN 61000-6-1:2007, EN 61000-6-3:2007/A1:2011.

**RoHS Directive
 2011/65/EU**

according to the following standard(s):
 EN 50581:2012.

Supplementary Information

The equipment complies with the following standards:
 UL508.

The above has been declared according to the global approach, module A.

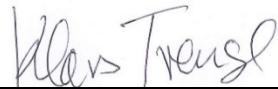
Authorized to compile the Technical File:

Klavs Tvenge
 Director of Business Development
 Struers ApS
 Pederstrupvej 84
 DK-2750 Ballerup, Denmark

Date of Issue: 2017.10.05

English

Declaration of Conformity

Manufacturer

Struers ApS
 Pederstrupvej 84
 DK-2750 Ballerup, Denmark
 Telephone +45 44 600 800

Herewith declares that

<i>Name:</i>	LaboDoser-100
<i>Cat. No.:</i>	06376902
<i>Function:</i>	Dosing unit
<i>Type No.:</i>	637

fulfils all the relevant provisions of the:
**Machinery Directive
 2006/42/EC**

according to the following standard(s):
 EN ISO 12100:2010, EN 60204-1:2006/AC:2010, EN 61010-1:2010.

and is in conformity with the:
**EMC Directive
 2014/30/EC**

according to the following standard(s):
 EN 61000-6-1:2007, EN 61000-6-2:2005, EN 61000-6-3:2007/A1:2011,
 EN 61000-6-4:2007/A1:2011, EN 61326-1:2013.

**RoHS Directive
 2011/65/EU**

according to the following standard(s):
 EN 50581:2012.

Supplementary Information

The equipment complies with the following standards:
 UL61010-1:2012, NFPA70:2014, NFPA79:2012,
 CAN-CSA 22.2 No. 1010-010-30, FCC 47 CFR Part 15 Class A, AS/NZS 2064.1/2.

The above has been declared according to the global approach, module A.

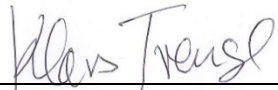
Authorized to compile the Technical File:

Klavs Tvenge
 Director of Business Development
 Struers ApS
 Pederstrupvej 84
 DK-2750 Ballerup, Denmark

Date of Issue: 2017.10.05



Pederstrupvej 84
DK-2750 Ballerup
Denmark

LaboForce-100

LaboDoser-100

Spare Parts and Diagrams



LaboForce-100
LaboDoser-100
Spare Parts and Diagrams

**Always state *Serial No* and *Voltage/frequency*
if you have technical questions or when ordering spare parts.**

The following restrictions should be observed, as violation of the restrictions may cause cancellation of Struers legal obligations:

Instruction Manuals: Struers Instruction Manuals may only be used in connection with Struers equipment covered by the Instruction Manual.

Service Manuals: Struers Service Manuals may only be used by a trained technician authorised by Struers. The Service Manual may only be used in connection with Struers equipment covered by the Service Manual.

Struers assumes no responsibility for errors in the manual text/illustrations. The information in this manual is subject to change without notice. The manual may mention accessories or parts not included in the present version of the equipment.

The contents of this manual are the property of Struers. Reproduction of any part of this manual without the written permission of Struers is not allowed.

All rights reserved. © Struers 2017.

Struers
Pederstrupvej 84
DK-2750 Ballerup
Denmark
Telephone +45 44 600 800
Fax +45 44 600 801

Spare Parts and Diagrams

Table of contents

Drawing

LaboForce-100

Drawings

LaboForce-100,complete	16360001C
Chassis w.pneu.a.HM,assembled (2 pages)	16360010I
LF-100 Cabinet top,assembly	16360012D
Chassis w.column,assembled	16360015F
Plunger,assembled	16360025B
Movement limits,assembled	16360028B
Chassis,assembled	16360033A
Doser hoses and outlet,assem.	16360041A
Ball joint, assembled	16030042A
Regulation manifold,assembled	16360055A
Pneumatic,assembled (2 pages).....	16360056D
Stop cover,assembled.....	16360065C
Top yoke,assembled	16360074A
HW plate,assembled.....	16360080A
Panel, assembled.....	16360083A
Friction coupling, assembl.....	15590013G

LaboDoser-100

LaboDoser-100,assembly	16370001F
------------------------------	-----------

Diagrams

LaboForce 100 LaboDoser-100 Block diagram	16363050C
LaboForce-100 LaboDoser-100 circuit diagram	16363100D
Wiring diagram (4 pages)	16363450C
LaboDoser-100, Wiring diagram	16373450A
LaboSystem Block diagram total overview	16203051BA

Some of the drawings may contain position numbers
not used in connection with this manual.

LaboForce-100
LaboDoser-100
Spare Parts and Diagrams

The following is a list of the spare parts that may need replacement during the lifetime of the equipment.

To check the availability of other replacement parts, please contact your local Struers Service Technician. It may help identify the part by referral to its position number on the assembly drawings included in this manual.

Spare part list for LaboForce-100

Drawing
16360001

Pos.	Spare Part	Cat no:
	LaboForce-100,complete	
10	Chassis w.pneu.a.HM,assembled	16360010
20	LF-100 Cabinet top,assembly	16360012
30	Hex.sock.scr. M5x10 A2 ISO7380, 3 pcs.	2TR80510
40	Hex.sock.scr. M5x12 A2 DIN912	2TR50512
50	Ejot Easyboss V 40	2GT00040
60	Ejot scr. DeltaPT wn5451 40x16	2TX04016
70	Cable tie 2.5x100 mm	2GK80010
80	Wireset, Laboforce-100	16363590
90	LaboForce-100,M Ref.Tags White	77205764
100	Printed type pl.70x32,bar,WEEE	77206018
110	Label Final Test Approved Big	10161005
120	Label: FCC rules	10160181
130	Label for connector plate	10160557
140	Label Warning for air 9,9/6bar	10160556

LaboForce-100
 LaboDoser-100
 Spare Parts and Diagrams

Spare part list for LaboForce-100

Drawing
 16360010

Pos.	Spare Part	Cat no:
	Chassis w.pneu.a.HM,assembled	
10	LF-100 Cabinet bottom,assembly	16360013
20	Chassis w.column,assembled	16360015
30	Specimen Mover Head,assembled	16360030
40	Pneumatic,assembled	16360056
50	Distance ring	16360229
60	Pulley 32 3M	16030125
70	Washer M5xø30	16030230
80	Ball joint, assembled	16030042
90	Doser hoses and outlet,assem.	16360041
100	Hex.sock.scr. M8x70 A2 DIN912, 3 pcs.	2TR50870
110	Toothed belt GT 3MR-480-09	2JT60480
120	Hex.sock.scr. M5x8 A2 DIN912, 3 pcs.	2TR50508
130	Self-locking nut M5 A2 DIN985, 4 pcs.	2TA40050
140	Washer 5 A2 DIN125A	2ZA10005
150	O-ring 72 NBR 872. 4.00-2.00, 4 pcs.	2IO10005
160	Silicone hose ø4/ø6	2NU11454
170	O-Ring NBR 70. 5.00-2.00, 4 pcs.	2IO20005
180	Sock.set scr.M5x30 70A2 DIN916, 4 pcs.	2TI10530
190	Hex.sock.scr. M5x16 A2 DIN7991	2TR70516
200	Crinkle washer M5 A2 BS4463, 6 pcs.	2ZI20503
210	Hex.sock.scr. M5x10 A2 DIN912, 9 pcs.	2TR50510
220	Check-nut M6 A2 DIN439B, 3 pcs.	2TA20060
230	Nylon piece ø17.1-ø17.4/12.7	2GK53331
240	Washer 5 A2 DIN9021A, 4 pcs.	2ZA20005
250	Hex.sock.scr. M5x12 A2 ISO7380, 2 pcs.	2TR80512
260	V-ring VS-0040	2IV00040
270	Crinkle washer M8 A2 BS4463, 3 pcs.	2ZI20804
290	HW plate,assembled	16360080
300	Cable tie 2.5x100 mm	2GK80010
310	Union. straight KQ2S06-M5	2NF90605
320	Force. motor assembl. w. plug	16363556

LaboForce-100
 LaboDoser-100
 Spare Parts and Diagrams

Spare part list for LaboForce-100

Drawing	Pos.	Spare Part	Cat no:	
16360012		LF-100 Cabinet top,assembly		
	20	Foil, LaboForce-100	16360300	
	30	PCB for SMM, Tested	15483004	
	40	Knob assembled	15730016	
	60	PCB MultiPurpose,Test+Bootload	16013000	
	70	Seal PUR shore 80	16030292	
	100	Display 320x240 TFT-color, LED	2HD50200	
	110	Turn/pushEncoderW.cable6inch24	2HR12413	
	120	Bracket for memory stick	16030174	
	140	Display Flat Cable, 40p, 210mm	2WF01150	
	16360015		Chassis w.column,assembled	
		20	Plunger,assembled	16360025
		40	Brake disc	15590225
		50	Column	16360150
80		Brake calipre, assembl.	15590020	
90		Namur 0,8mm - ø6x18, assembled	15590035	
100		Top yoke,assembled	16360074	
110		Friction coupling, assembl.	15590013	
120		Compression spring 25.25x2.75	15590192	
150		O-Ring NBR 70. 38.0-2.50	2IO25038	
170		Coupler dir 4-M5, KQ2H04-M5	2NF10009	
180		Fitting elbow d4,M5x0,8	2NF42045	
210		Filter regulator AW10-M5H-2	2YF00008	
240		Union. straight KQ2S04-M5, 2 pcs.	2NF90405	
330		Rotating angle KSL04-M6	2NF10134	
16360025			Plunger,assembled	
	110	Piston sealing 428565 ø30/ø8x8	2IR03010	
	120	Spring guide	15590162	
	130	Plunger	15590163	
16360033		Chassis,assembled		
	20	Flange bearing, machined	15590121	
	30	Internal circlip J62 DIN472, 2 pcs.	2ZL20620	
	40	Shim PS50x62x1 DIN988, 2 pcs.	2ZP50010	
	50	Slide bearing PAP 4040 P10	2BG14040	
	90	Ball bearing 6007 2RS1 ø35/ø62, 2 pcs.	2BK00110	
	100	Wave spring 37x45x0.5	2GF60030	
	110	Alignment disc PS 36x45x1.5 DIN 988	2ZP36015	

LaboForce-100
 LaboDoser-100
 Spare Parts and Diagrams

Spare part list for LaboForce-100

Drawing	Pos.	Spare Part	Cat no:
16360041		Doser hoses and outlet,assem.	
	30	TYGON hose AJK00003 1/16x3/16	2NU91303
	40	TYGON hose AED00007 1/8x1/4	2NU91307
	50	Reduct.piece, angle L230/220-6, 4 pcs.	2NG20088
16360055		Regulation manifold,assembled	
	20	Union. straight KQ2S04-M5, 5 pcs.	2NF90405
	40	Gasket, PVC O-1/8	2IF00011
	50	Sol.valve V114 -5G, NC, 3 pcs.	2YM10125
	60	Sol.valve V114A -5G, NC, 4 pcs.	2YM10126
	70	Sound absorber AN120-M3, 4 pcs.	2YL12003
	90	Silencer AN120-M5	2YL00120
	100	Throt.CheckValve AS1201F-M5-04, 2 pcs.	2YI01201
16360056		Pneumatic,assembled	
	40	Hose PU ø2.5/ø4. TU 0425 BU	2NU14425
16360065		Stop cover,assembled	
	20	O-ring 72 NBR 872. 27.00-1.50	2IO27015
	30	Piston sealing RT0100120-T10N	2IR01232
	60	O-ring 72 NBR 872. 21-2	2IO20021
15590013		Friction coupling, assembl.	
	70	O-ring 72 NBR 872. 40.00-4.00	2IO40070
		HW plate,assembled	
	40	10R Break resistor HSD70A	2RK05701
		Wireset, Laboforce-100	
	40	BP1 w. plug. Laboforce-100	16363554
	50	Namur HQ1 Laboforce-100	16363555
	55	Namur HQ2 Laboforce-100	16363557
	60	LED back light wire extender	2WC60500
	70	LED strip 24V,15W/m	2HL03528
	Loose parts,LaboForce-100		
10	Connection piece ø6 to 1_8 in	16030057	

LaboForce-100
LaboDoser-100
Spare Parts and Diagrams

Spare part list for LaboDoser-100

Drawing
16370001

Pos.	Spare Part	Cat no:
	LaboDoser-100,assembly	
10	Pump motor w. wire & crimp, 4 pcs.	16373560
30	Cabinet, painted	16379102
	Loose parts, LaboDoser-100	
10	TYGON hose AED00007 1/8x1/4	2NU91307
20	TYGON hose AED00007 1/8x1/4	2NU91307
30	Spiral hose SPF 15	2WK90015
50	Bottle ½L, nipple ø3, assem, 4 pcs.	16080611

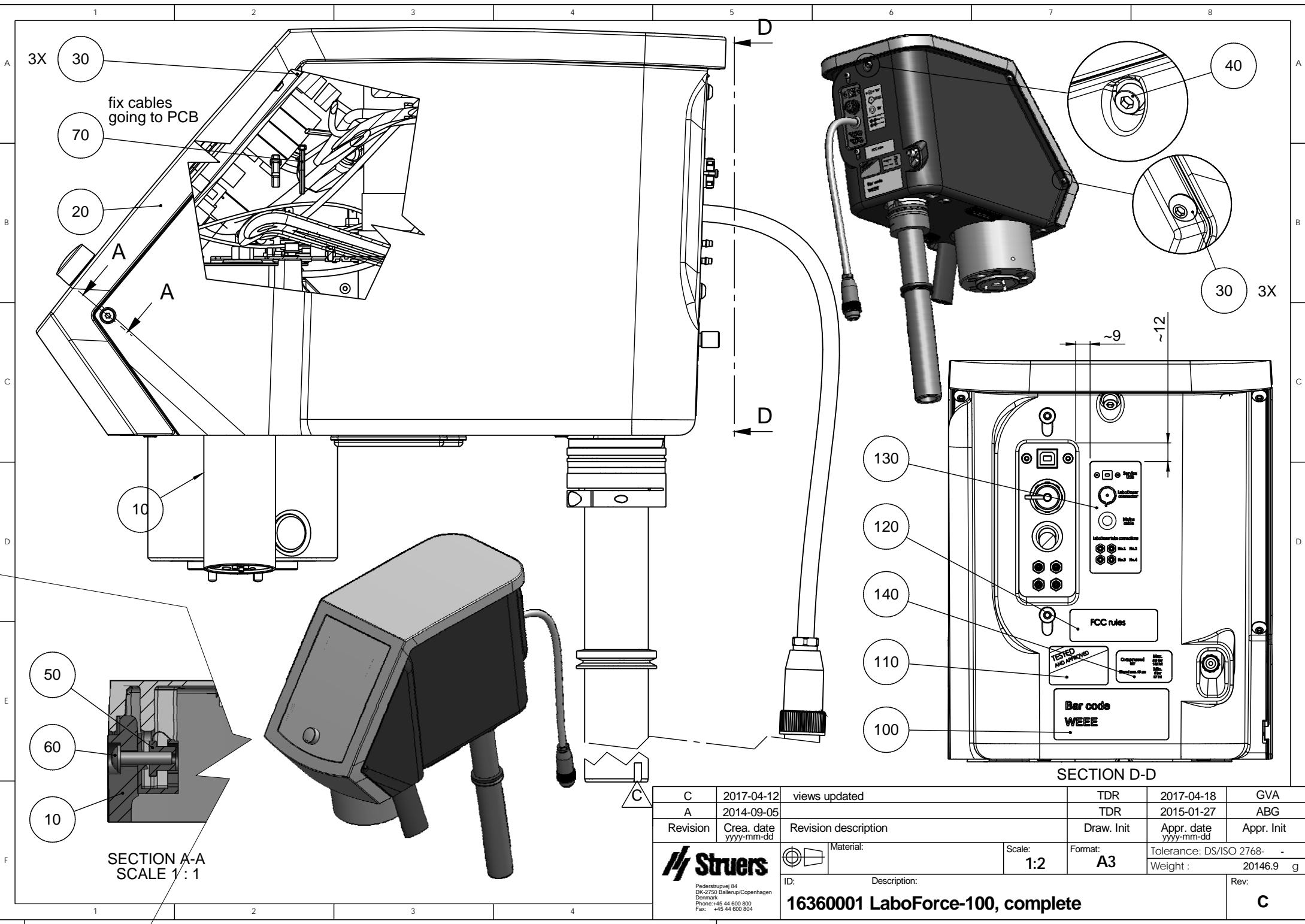

SECTION A-A
SCALE 1 : 1

SECTION D-D

C	2017-04-12	views updated	TDR	2017-04-18	GVA
A	2014-09-05		TDR	2015-01-27	ABG
Revision	Crea. date yyyy-mm-dd	Revision description	Draw. Init	Appr. date yyyy-mm-dd	Appr. Init
		Material:	Scale: 1:2	Format: A3	Tolerance: DS/ISO 2768- Weight : 20146.9 g
ID:	Description:				Rev:
16360001 LaboForce-100, complete					C

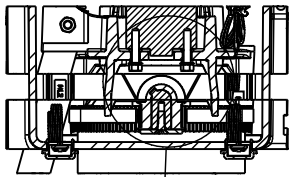

SECTION C-C

Tighten, when doser inside bottom cabinet with Loctite 222

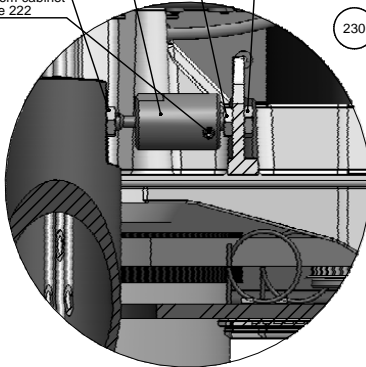

DETAIL B
SCALE 1 : 1

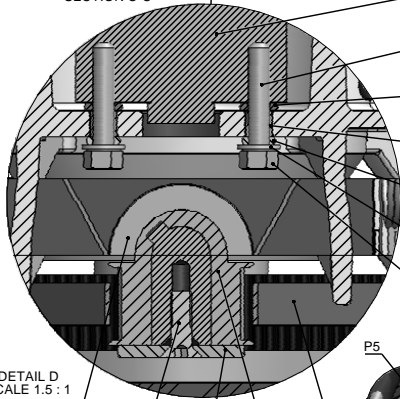

DETAIL D
SCALE 1.5 : 1

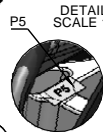

DETAIL E
SCALE 1 : 1

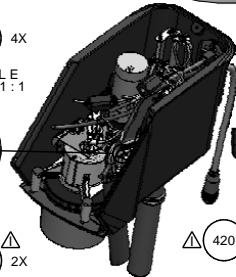

See wiringset 16363590

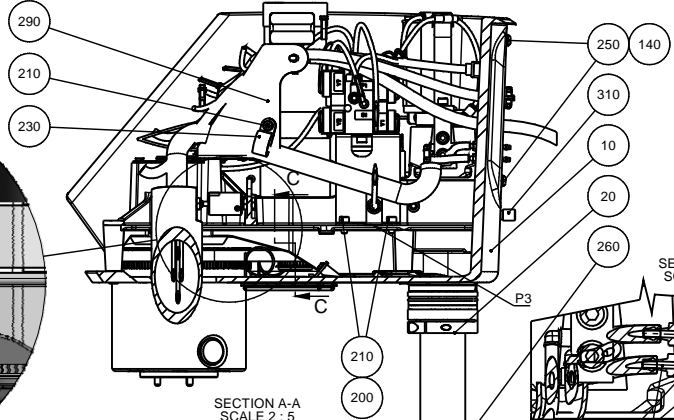

SECTION A-A
SCALE 2 : 5

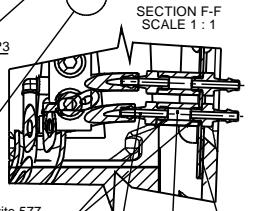

SECTION F-F
SCALE 1 : 1

Loctite 577
2 thread turns

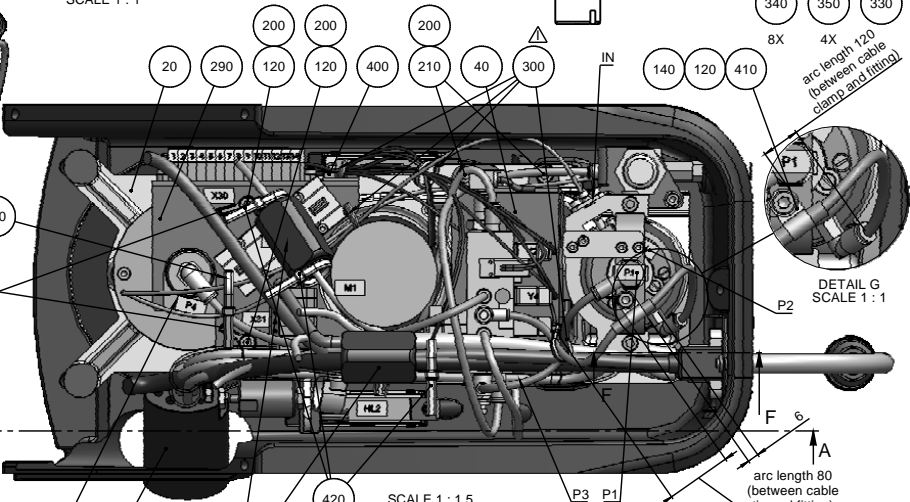

SCALE 1 : 1.5

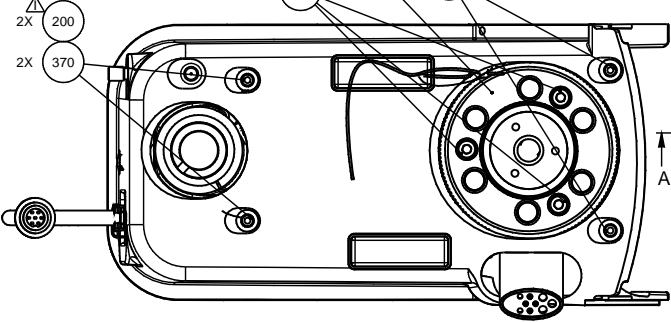
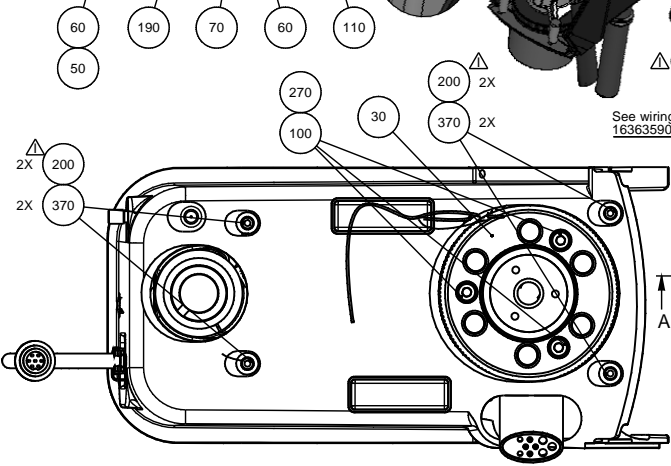

I	2017-04-12	removed pos.240; added 4x pos.200, 2x pos.300, new pos.420	TDR	2017-04-18	GVA
A	2014-09-05		TDR	2015-01-27	ABG
Revision	Creas. date	Revision description	Draw. Init	Appr. date	Appr. Init
		Material:	Scale: 1:2	Format: A2	Tolerance: DS/ISO 2768-
					Weight: 19047,0 g
ID:	Description:				sheet 1 of 2
16360010 Chassis w. pneu.a.HW,assembled					Rev: I

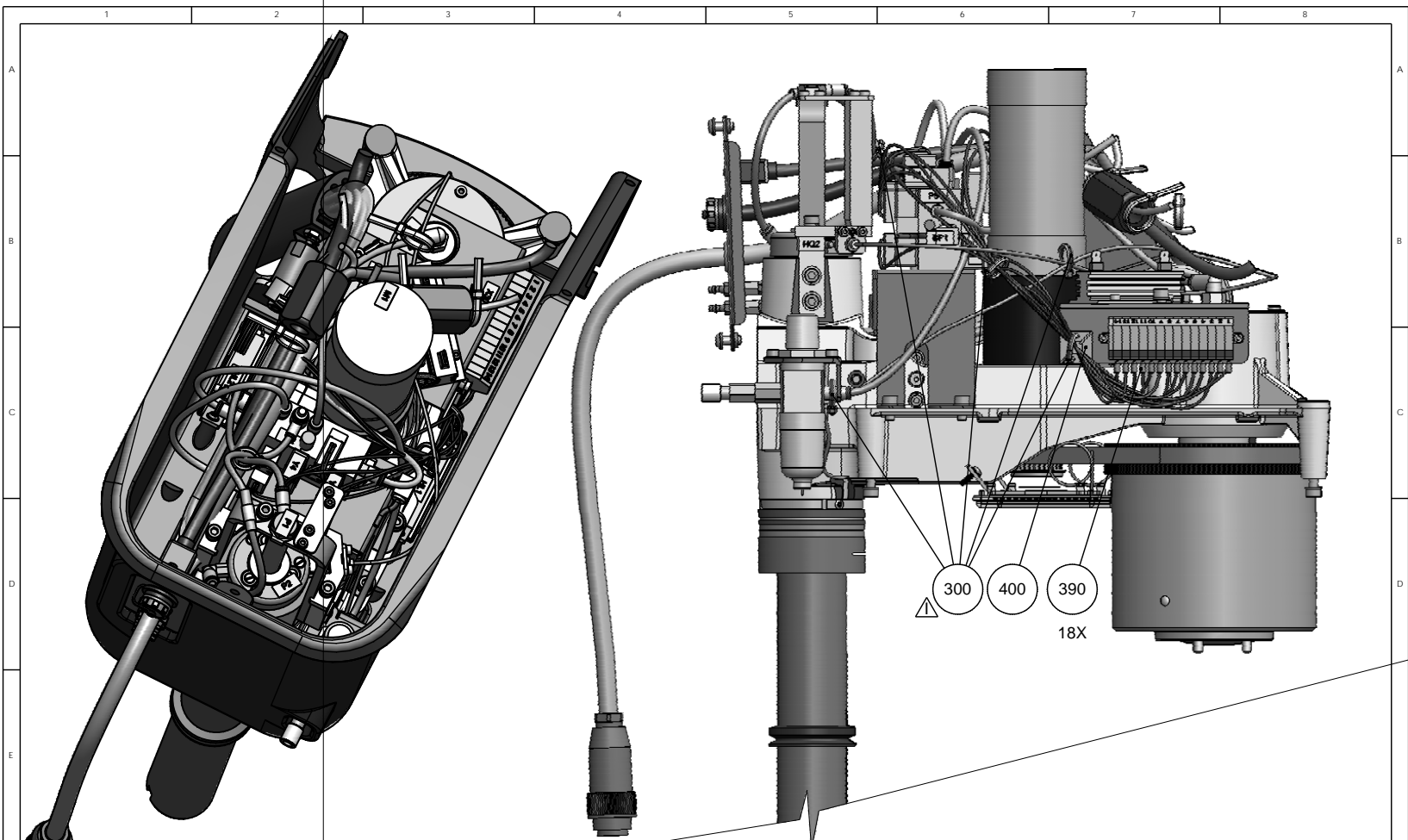

△	I	2017-04-12	removed pos.240; added 4x pos.200, 2x pos.300, new pos.420	TDR	2017-04-18	GVA
	A	2014-09-05		TDR	2015-01-27	ABG
	Revision	Crea. date	Revision description	Draw. Init	Appr. date	Appr. Init
		yyyy-mm-dd			yyyy-mm-dd	
			Material:	Scale:	Format:	Tolerance: DS/ISO 2768-
				1:2	A3	Weight : 19047.0 g
	ID:		Description:	sheet 2 of 2		Rev: I
			16360010 Chassis w. pneu.a.HW,assembled			



Federstrømsvej 84
DK-2750 Ballerup/Copenhagen
Denmark
Phone: +45 44 600 800
Fax: +45 44 600 804

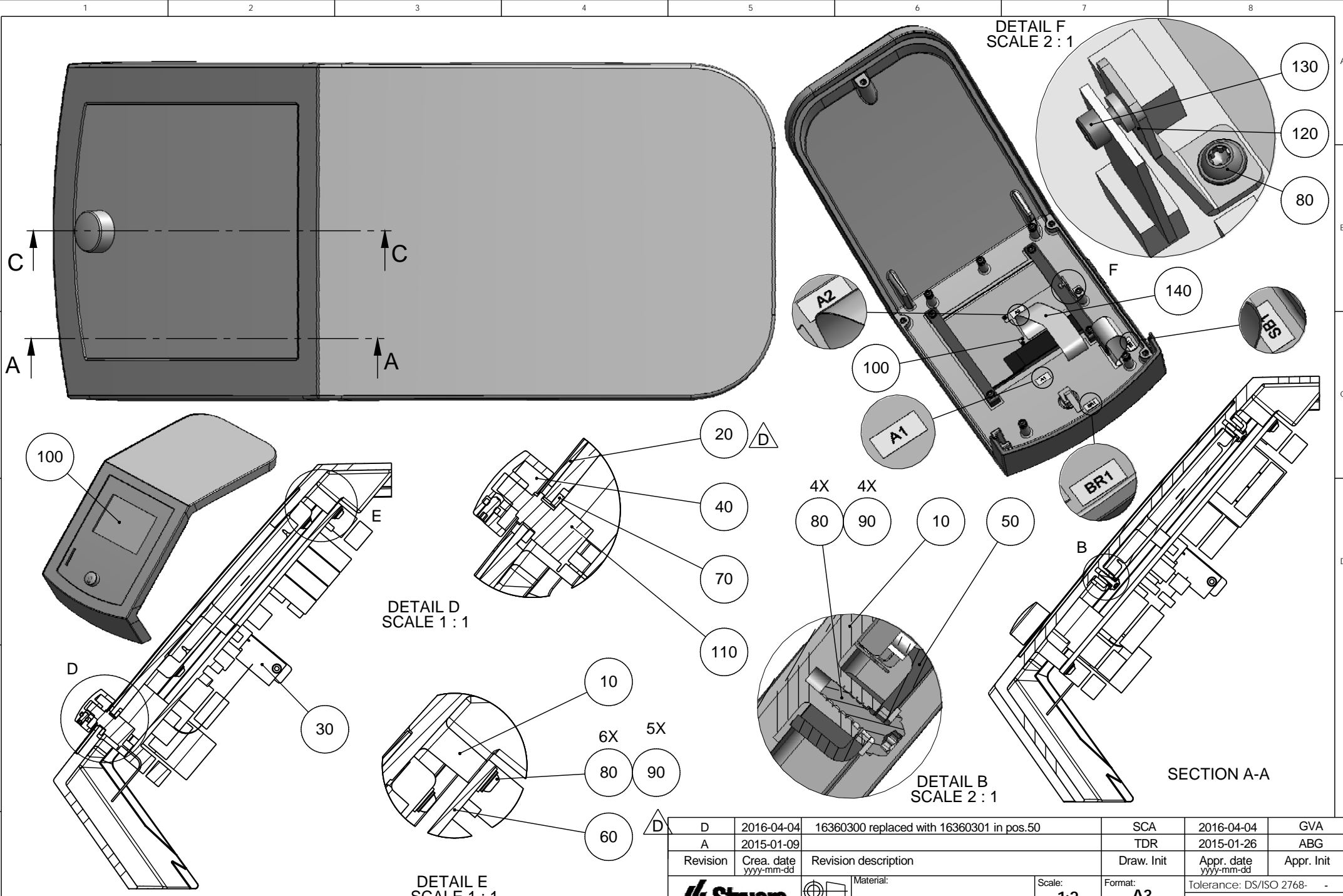

SECTION C-C

DETAIL D
SCALE 1 : 1

DETAIL E
SCALE 1 : 1

DETAIL B
SCALE 2 : 1

DETAIL F
SCALE 2 : 1

SECTION A-A

D	2016-04-04	16360300 replaced with 16360301 in pos.50	SCA	2016-04-04	GVA
A	2015-01-09		TDR	2015-01-26	ABG
Revision	Crea. date yyyy-mm-dd	Revision description	Draw. Init	Appr. date yyyy-mm-dd	Appr. Init
		Material:	Scale: 1:2	Format: A3	Tolerance: DS/ISO 2768- Weight : 1088.6 g
ID:	Description: 16360012 LF-100 Cabinet top,assembly				Rev: D

Struers
 Pederstrupvej 84
 DK-2750 Ballerup/Copenhagen
 Denmark
 Phone: +45 44 600 800
 Fax: +45 44 600 804

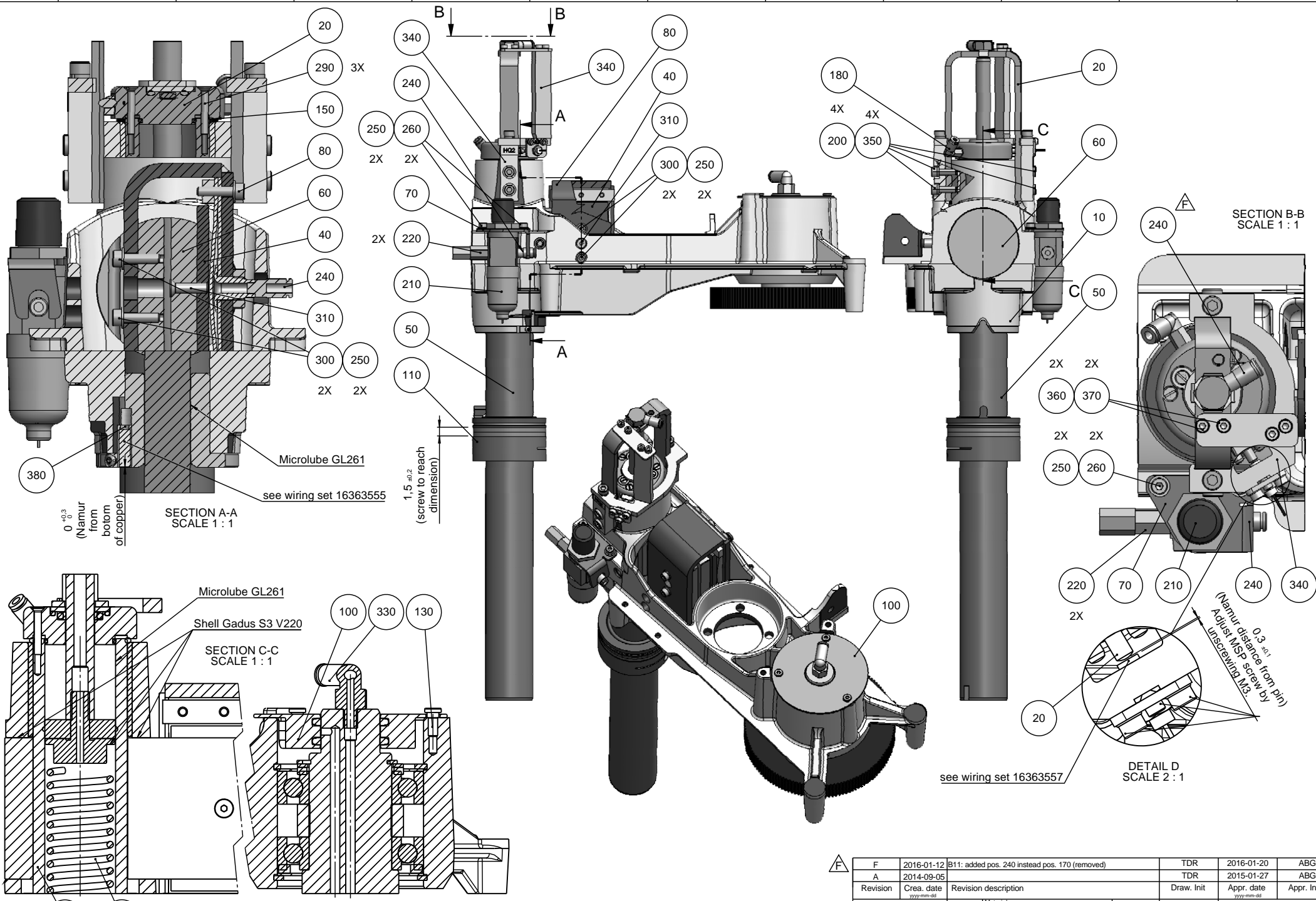

F	2016-01-12	B11: added pos. 240 instead pos. 170 (removed)	TDR	2016-01-20	ABG
	A	2014-09-05		TDR	2015-01-27
Revision	Crea. date yyyy-mm-dd	Revision description	Draw. Init	Appr. date yyyy-mm-dd	Appr. Init
Material:		Scale:	Format:	Tolerance: DS/ISO 2768-	
ID:		Description:	1:2	A2	Weight: 11081.2 g
 Fabrikvej 14 DK-2750 Ballerup/Copenhagen Denmark Phone: +45 44 800 800 Fax: +45 44 800 904					F
16360015 Chassis w.column,assembled					

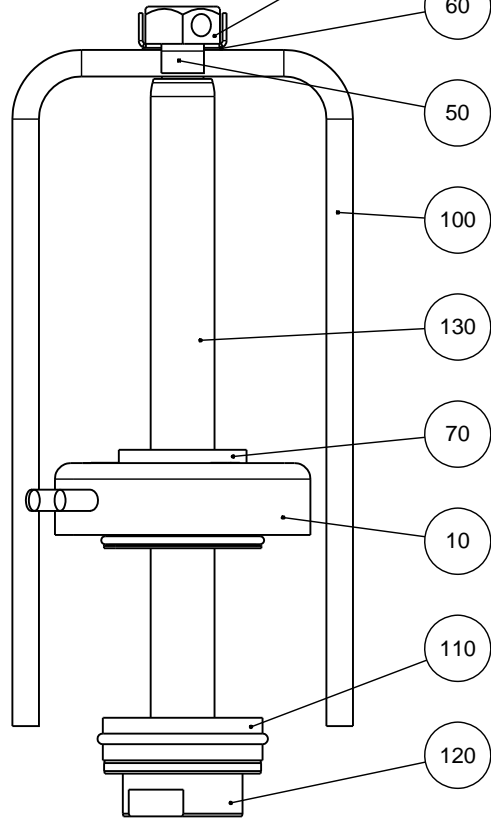
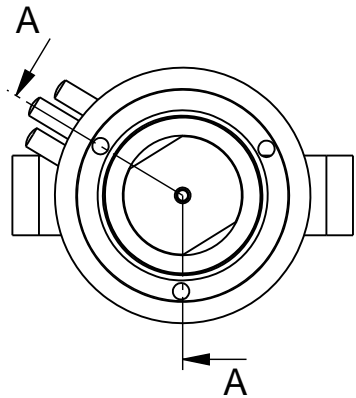

40 teflon tape,
5 turns to thread

60

50

100

130

70

10

110

120

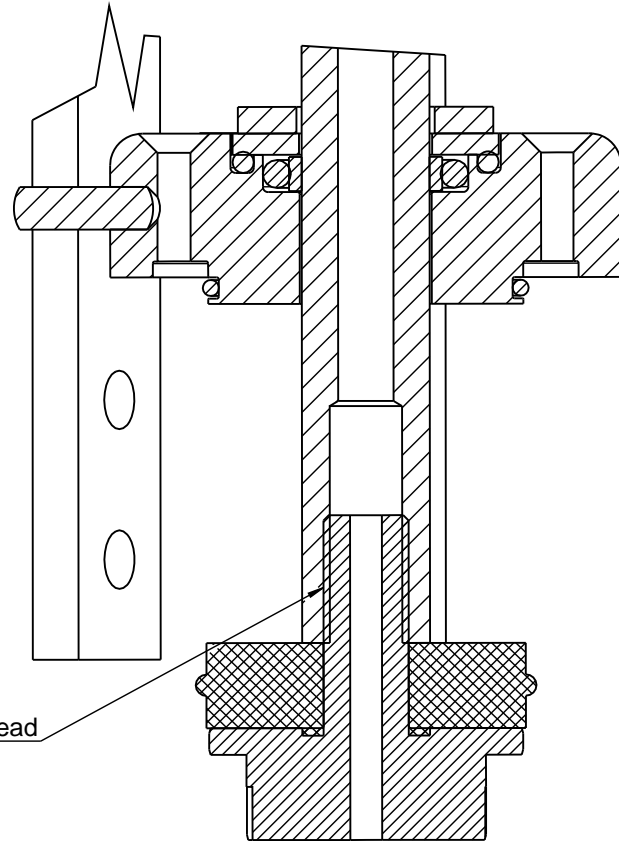

teflon tape,
5 turns to thread

SECTION A-A
SCALE 2 : 1

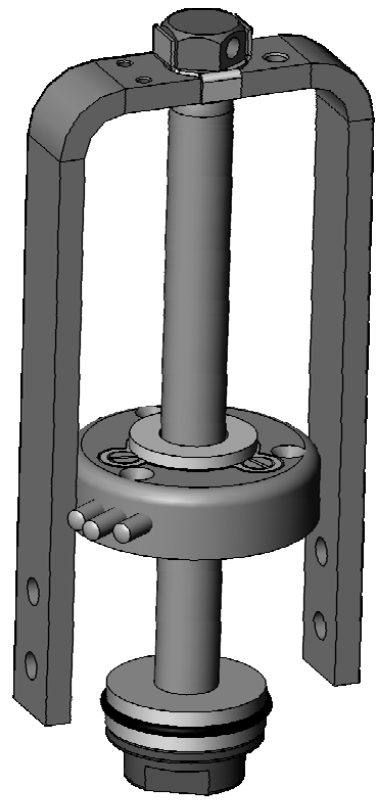

Recommended assembling procedure:

1. pos. 110 + 120 gently into 130
2. lead pos. 10 and 70 to 130
3. by hand turning pos. 120 screw pos. 40 through 60 and 100 into 130
4. fix gently pos. 60 with 40 into vise (clamp) and screw 120 with approx. torque of 5 Nm

B	2015-04-27	removed 20,30,80,90;added 100-130;added assembl.note	TDR	2015-04-28	ABG
A	2014-09-05		TDR	2014-09-05	ABG
Revision	Crea. date yyyy-mm-dd	Revision description	Draw. Init	Appr. date yyyy-mm-dd	Appr. Init
		Material:	Scale: 1:1	Format: A3	Tolerance: DS/ISO 2768- Weight : 0,575 g
ID:	Description: 16360025 Plunger, assembled				Rev: B

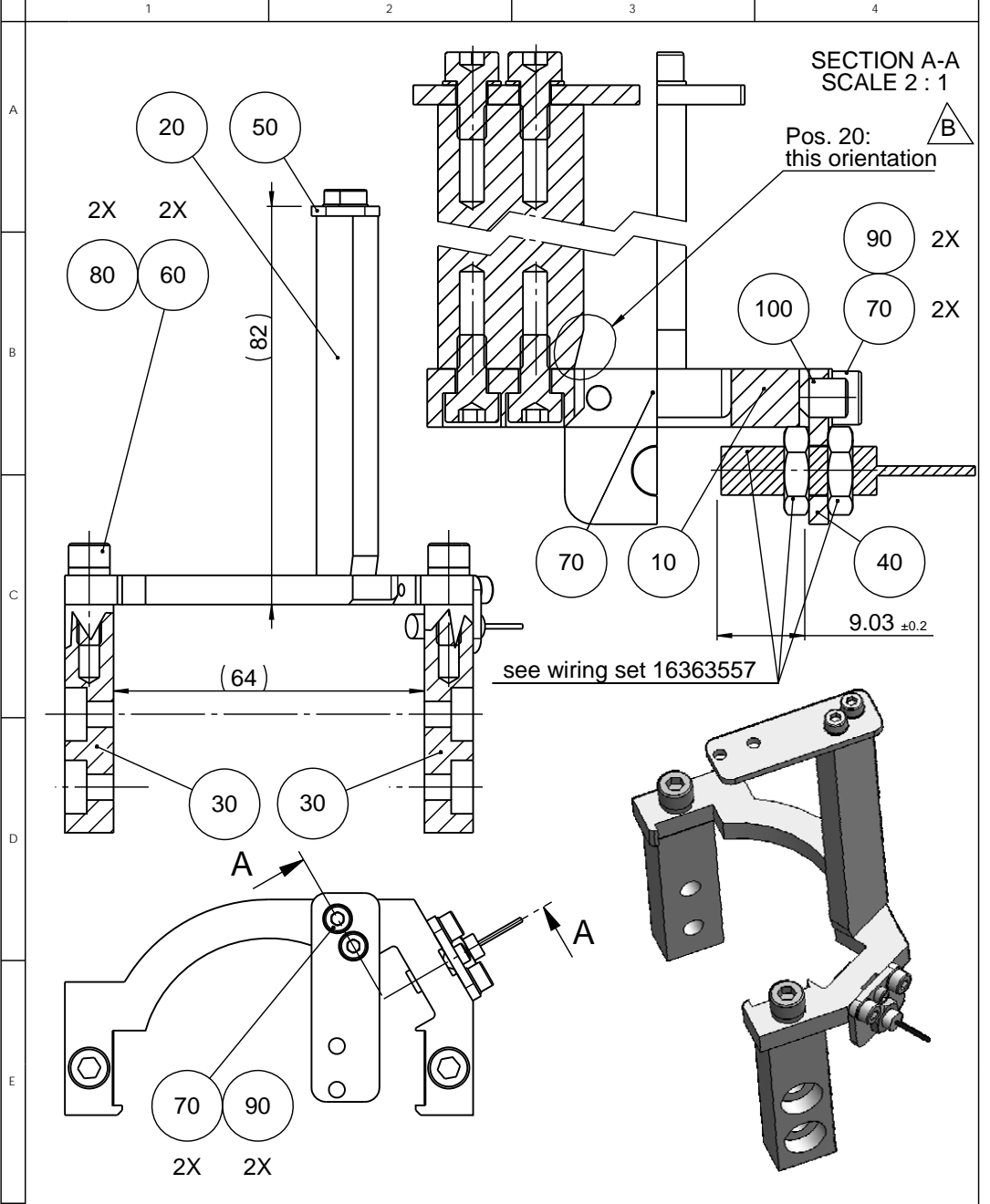

B	2015-10-09	A4: added note; refreshed views	TDR	2015-10-16	ABG
A	2015-04-20		TDR	2015-04-28	ABG
Rev	Crea. date yyyy-mm-dd	Revision description	Draw. Init	Appr. date yyyy-mm-dd	Appr. Init
F	 Frederstrupvej 84 DK-2750 Ballerup Copenhagen Denmark Phone: +45 44600 800 Fax: +45 44600 804	Material:	Scale: 1:1	Format: A4	Tolerance: DS/ISO 2768 - - Weight : 226.5 g
		ID:	Description: 16360028 Movement limits, assembled		

10 90 40 130 30

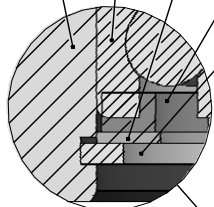

DETAIL E
SCALE 2 : 1

70 100 110 120 30 40 10 90

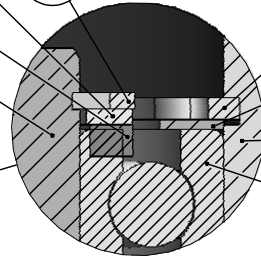

DETAIL C
SCALE 2 : 1

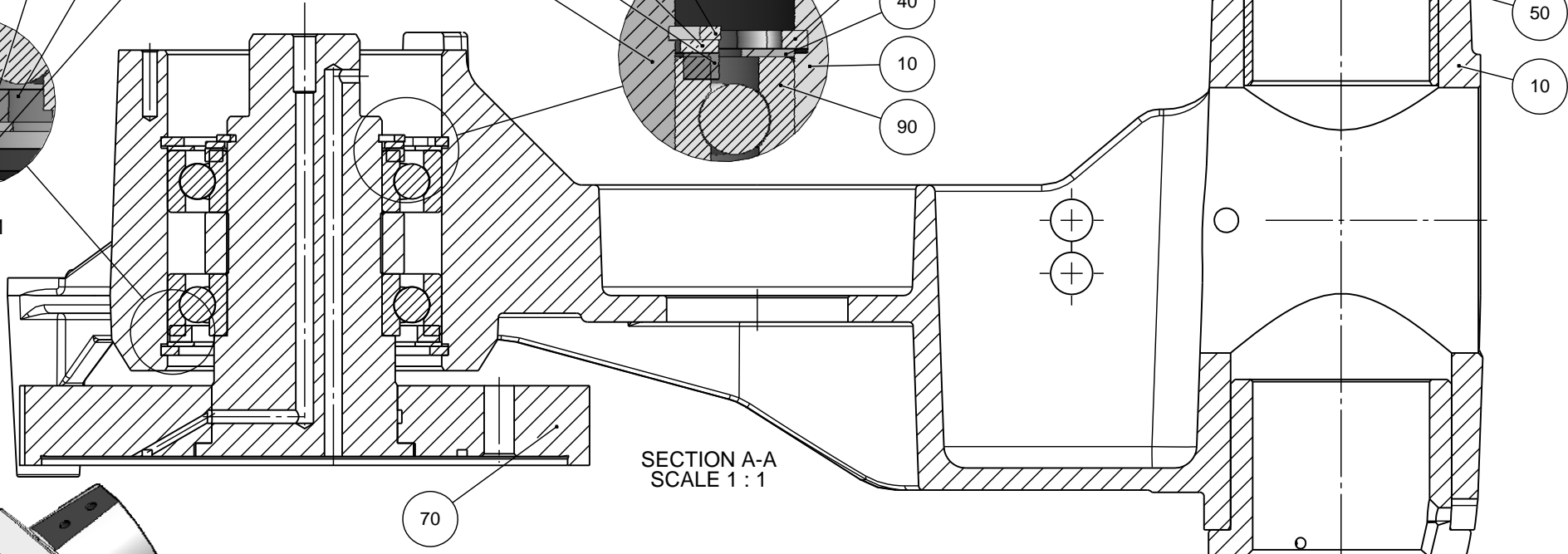

SECTION A-A
SCALE 1 : 1

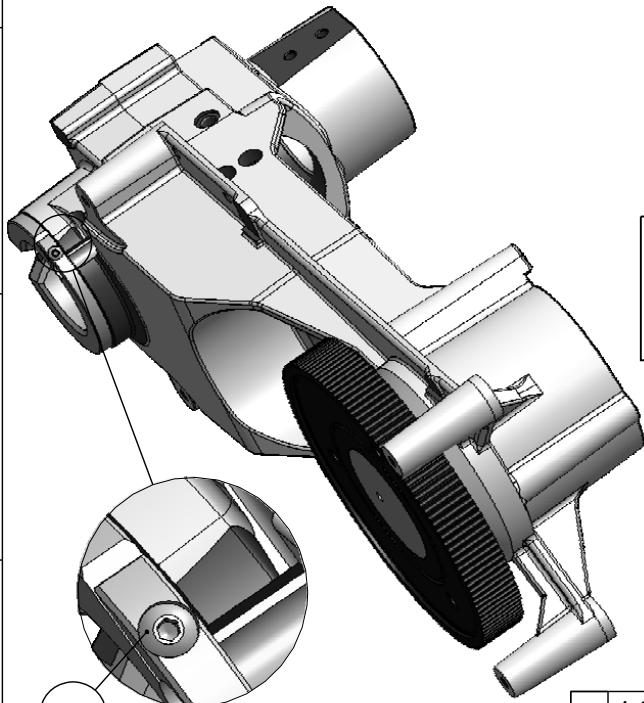

DETAIL D
SCALE 2 : 1

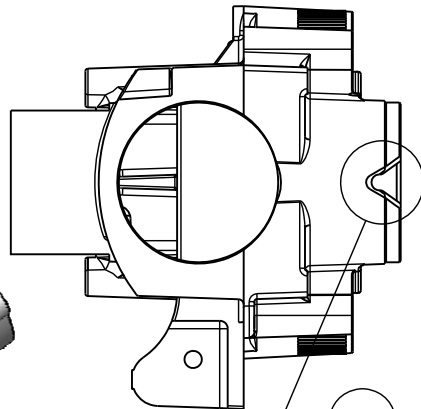

DETAIL B
SCALE 1 : 1

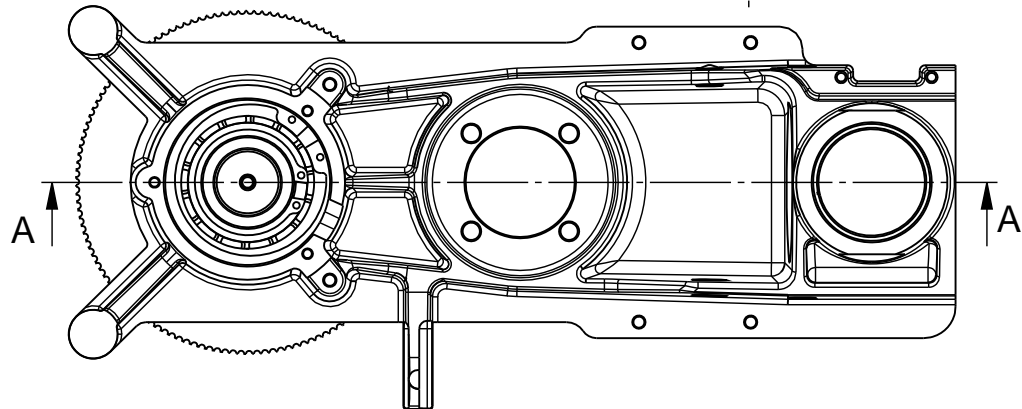

≡ 1.0 A

A					
A	2014-08-12		TDR	2015-01-27	ABG
Revision	Crea. date yyyy-mm-dd	Revision description	Draw. Init	Appr. date yyyy-mm-dd	Appr. Init
		Material:	Scale: 1:2	Format: A3	Tolerance: DS/ISO 2768- Weight : 3839.2 g
ID:	Description:				Rev:
16360033 Chassis, assembled					A

Pederstrupvej 84
DK-2750 Ballerup/Copenhagen
Denmark
Phone: +45 44 600 800
Fax: +45 44 600 804

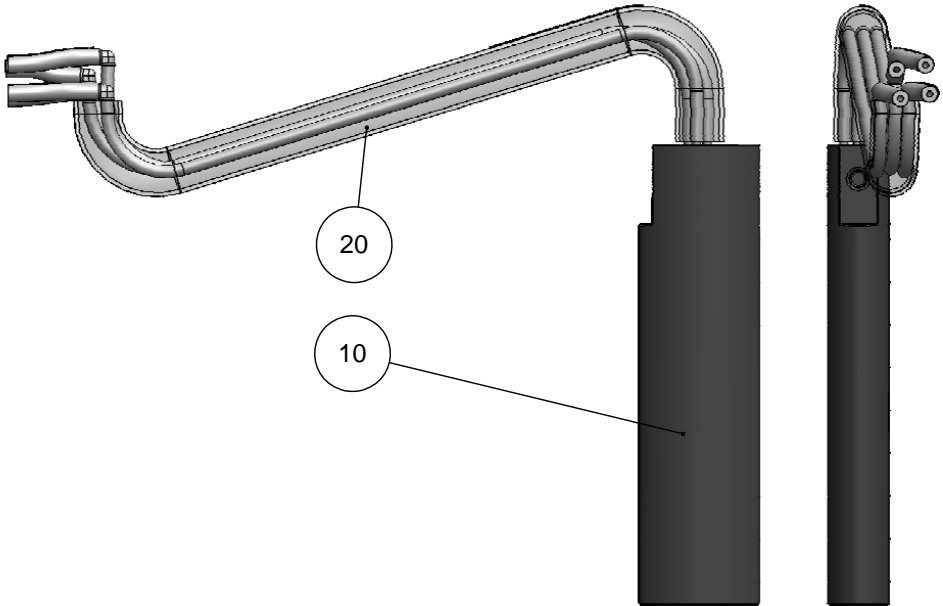
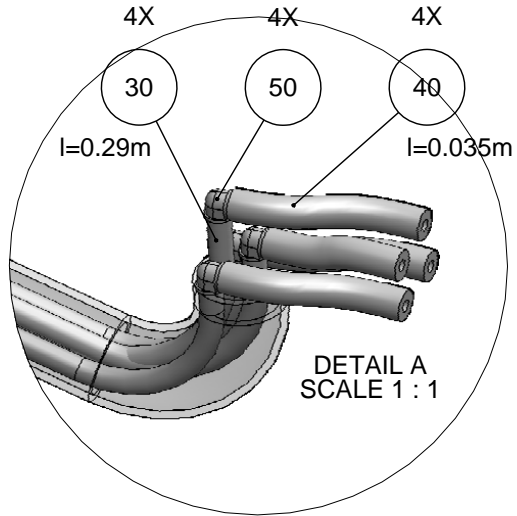
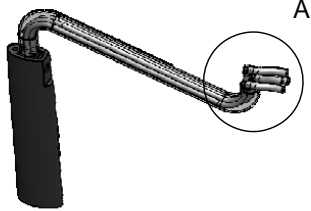

A						
A	2015-01-06			TDR	2015-01-07	ABG
Rev	Crea. date yyyy-mm-dd	Revision description		Draw. Init	Appr. date yyyy-mm-dd	Appr. Init
F			Material:	Scale: 1:2	Format: A4	Tolerance: DS/ISO 2768 - -
			ID:	Description: 16360041 Doser hoses and outlet, assembled	Weight : g	Rev: A

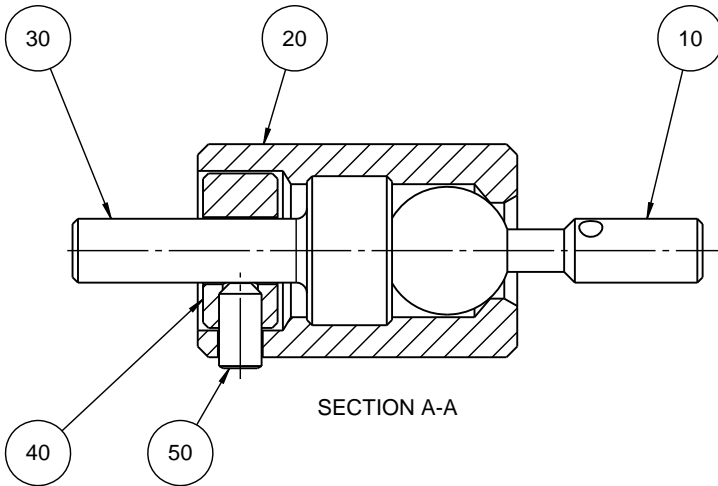
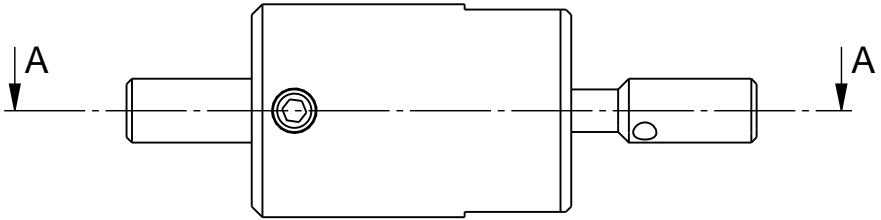

SECTION A-A

POS. NO.	AMOUNT	DRAW. NO.	NOTE
10	1	16030271 Ball	
20	1	16030272 Collar for ball joint	
30	1	16030274 Pin for ball joint	
40	1	16030275 Stop ring	
50	1	2T110408 MSP Skrue M4x8	

A
A 2010-11-05

Rev Crea. date Revision description

JLI 2010-11-05 JLI
Draw. Init Appr. date Appr. Init



Pederstrupvej 84
DK-2750 Ballerup
Copenhagen
Denmark
Phone: +45 44600 800
Fax: +45 44600 804



Material:

Scale:
2:1

Format:
A4

Tolerance: DS/ISO 2768 - -
Weight : 37.9 g

ID: Description:
16030042 Ball joint, assembled

Rev:
A

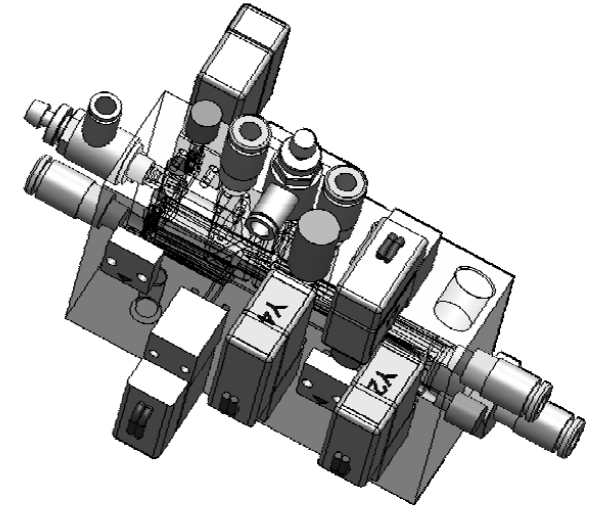
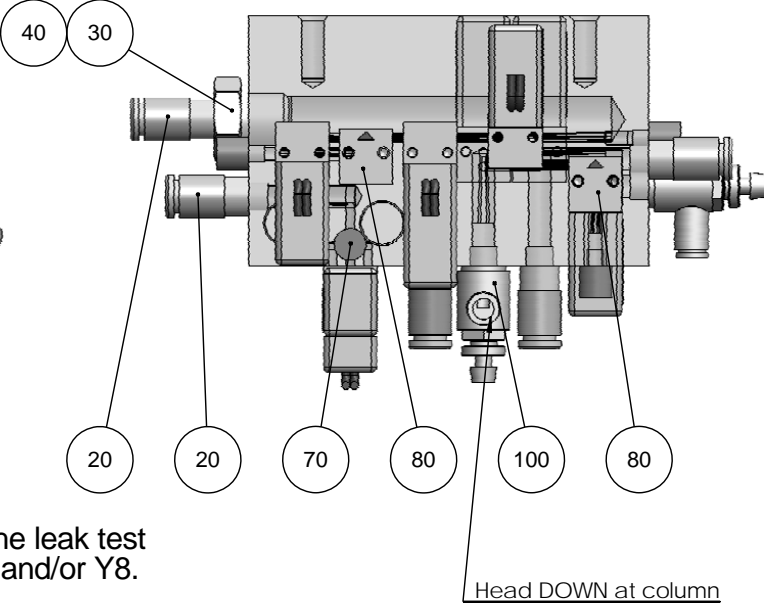
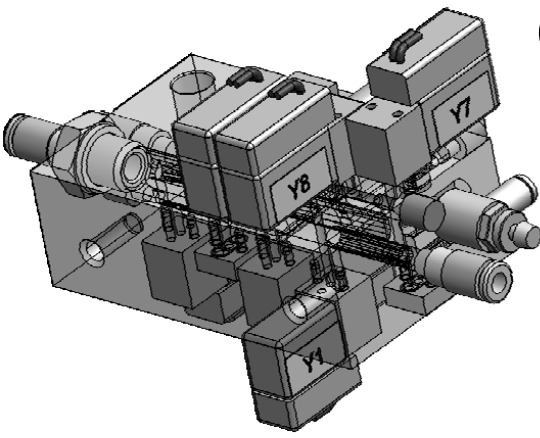
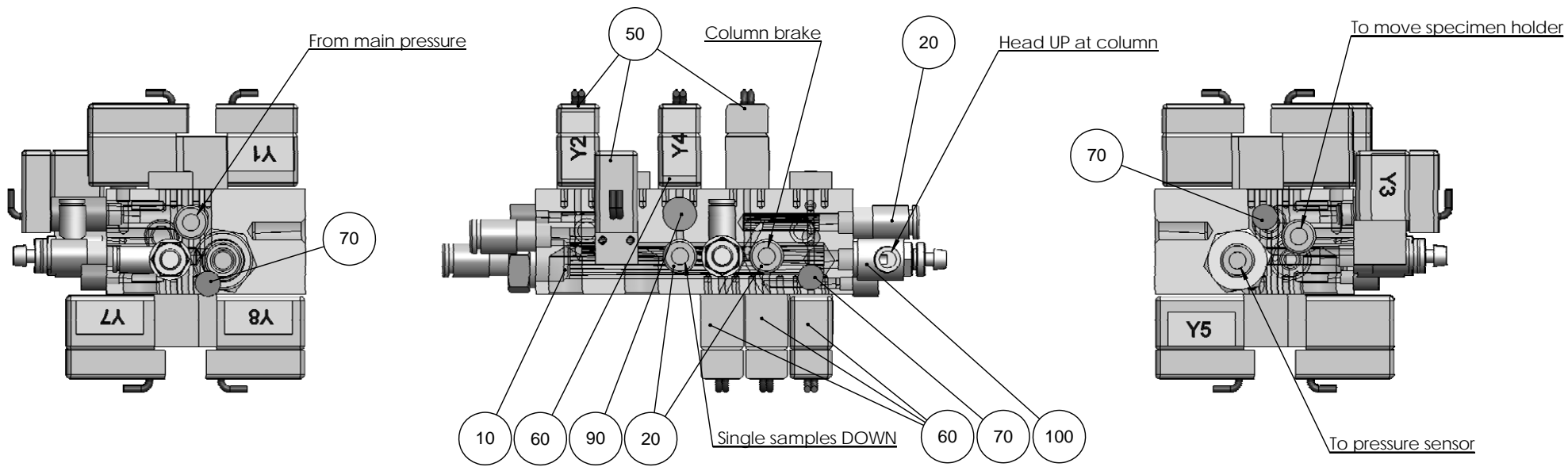

Attention when running a leak test:
 If the valve Y3 and/or Y4 and/or Y5 fail the leak test they can be replaced, and reused as Y7 and/or Y8.

Vær opmærksom på følgende ved leak test:
 Hvis ventil Y3 og/eller Y4 og/eller Y5 ikke består leak testen kan de afmonteres/erstattes, og bruges som Y7 og/eller Y8.

M2 mounting screws for valves pos. 50 and 60 use tightening torque 0,12Nm.

M2 skruer til montering af ventiler pos. 50 og 60 spændes med 0,12Nm.

Head DOWN at column

A					
A	2014-09-08		TDR	2015-01-26	ABG
Revision	Crea. date yyyy-mm-dd	Revision description	Draw. Init	Appr. date yyyy-mm-dd	Appr. Init
		Material:	Scale: 1:1	Format: A3	Tolerance: DS/ISO 2768- mK
			ID:	Description:	Weight : g
16360055 Regulation manifold, assembled					Rev: A

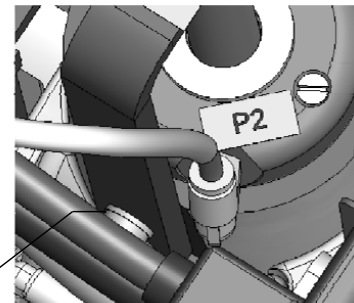
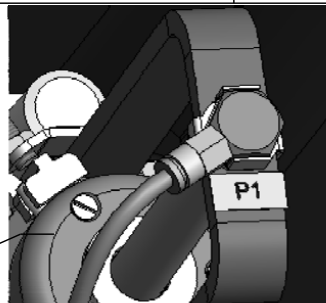
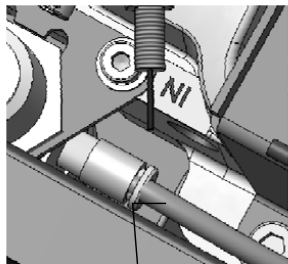

20cm

120
2.5cm



23cm

50

70 18cm

80
33.1cm

See wire set 16363554

90
24.0cm

40
24.7cm

60
22cm

30
100

10

30
100

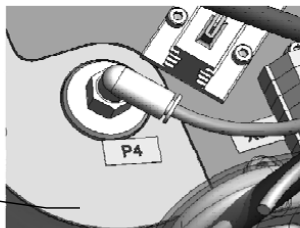
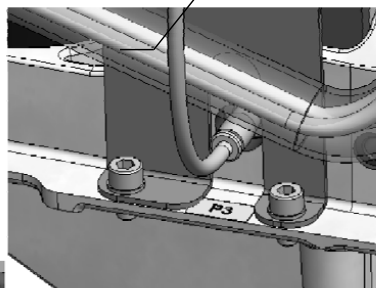
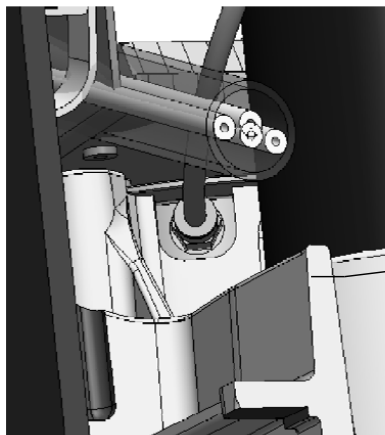

20

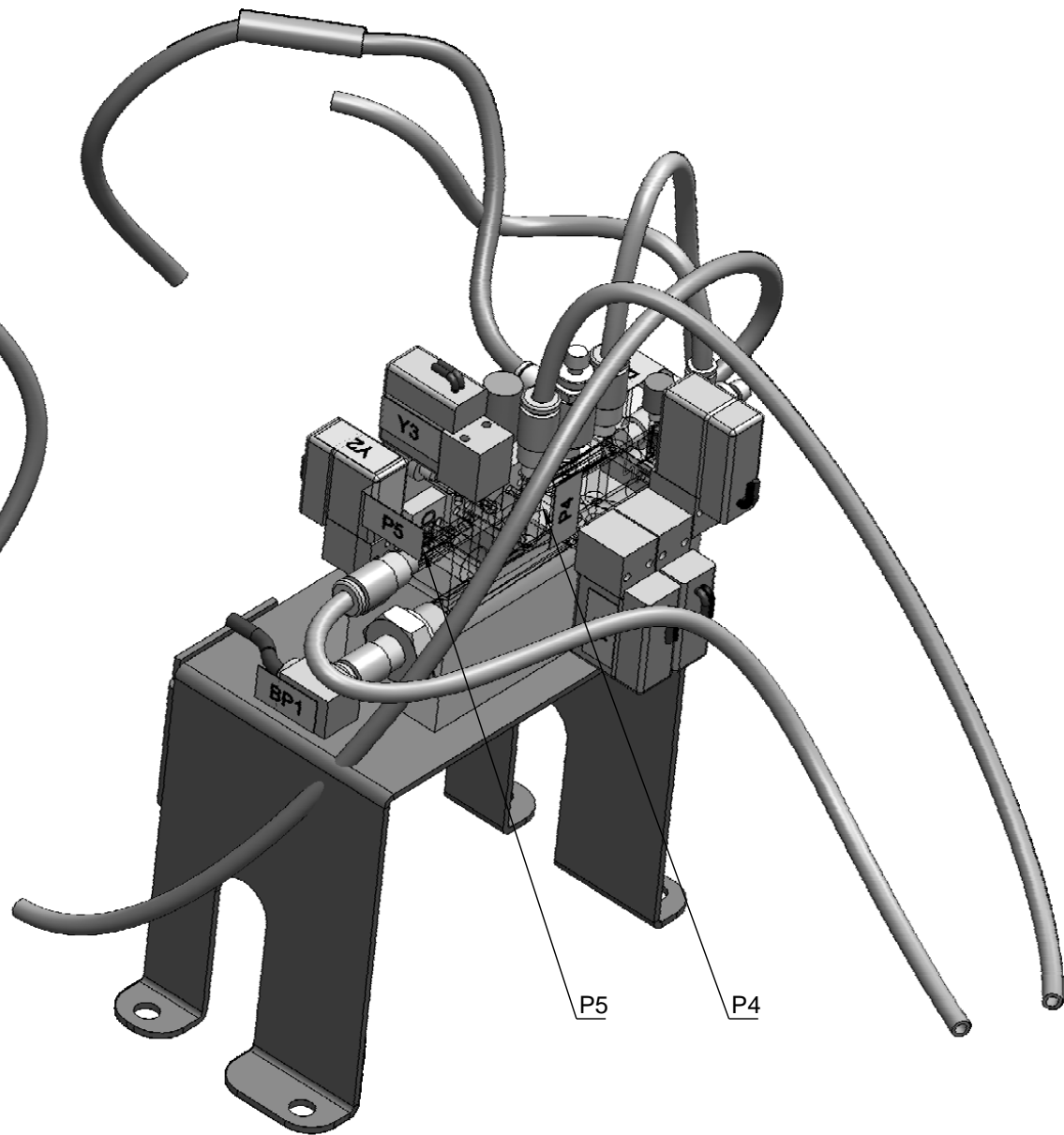
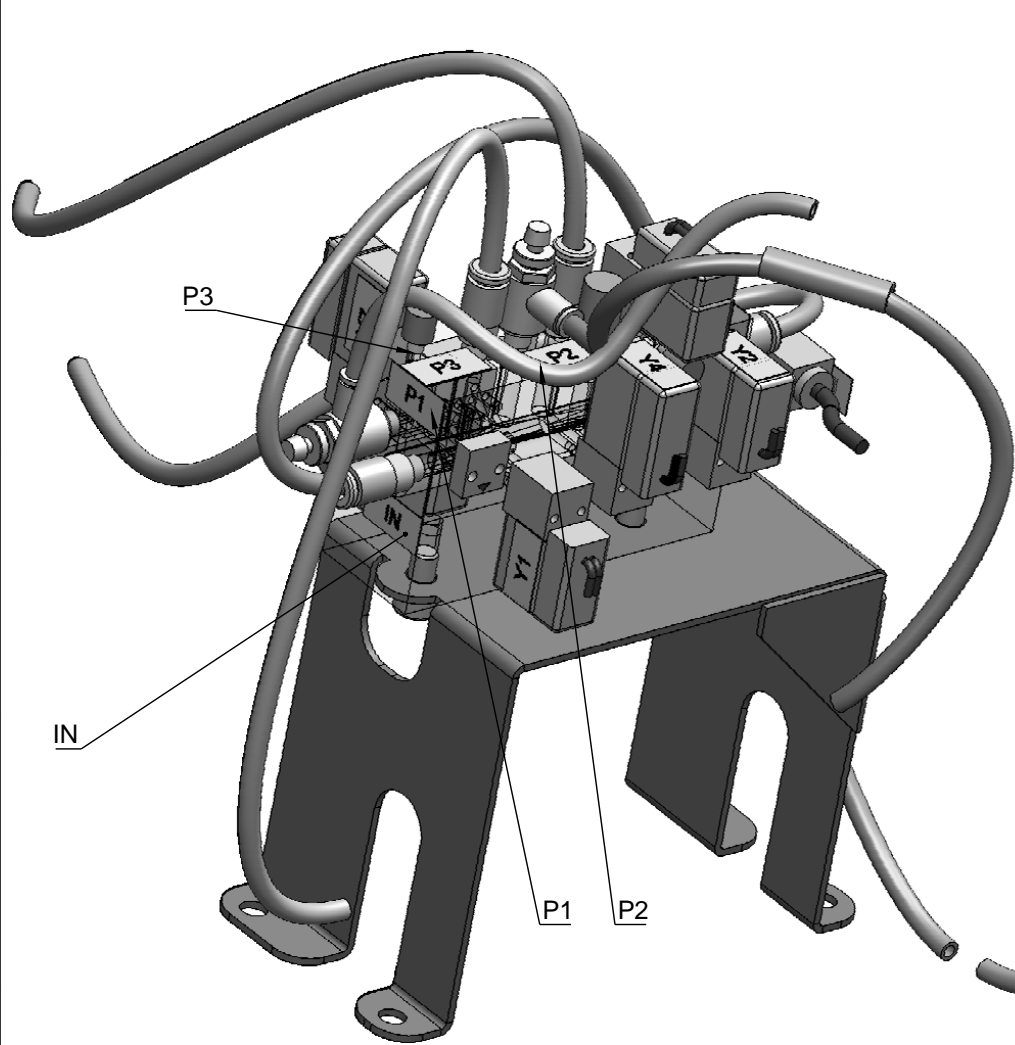

D	2016-10-03	removed pos. 110, added pos. 120	TDR	2016-10-10	GVA
A	2014-09-08		ABG	2014-09-10	TDR
Revision	Crea. date yyyy-mm-dd	Revision description	Draw. Init	Appr. date yyyy-mm-dd	Appr. Init
		Material:	Scale: 1:1	Format: A3	Tolerance: DS/ISO 2768- mK
ID:	Description:		Weight : 362.2 g		Rev:
16360056 Pneumatic, assembled			1/2		D

Pederstrupvej 84
DK-2750 Ballerup/Copenhagen
Denmark
Phone: +45 44 600 800
Fax: +45 44 600 804



D	2016-10-03	removed pos. 110, added pos. 120	TDR	2016-10-10	GVA
A	2014-09-08		ABG	2014-09-10	TDR
Revision	Crea. date yyyy-mm-dd	Revision description	Draw. Init	Appr. date yyyy-mm-dd	Appr. Init
 <small>Pederstrupvej 84 DK-2750 Ballerup/Copenhagen Denmark Phone: +45 44 600 800 Fax: +45 44 600 804</small>	 Material:	Scale: 1:1	Format: A3	Tolerance: DS/ISO 2768- mK	
				Weight : 362.2 g	
ID:	Description:			Rev:	
16360056 Pneumatic, assembled				2/2	D

A

B

C

D

E

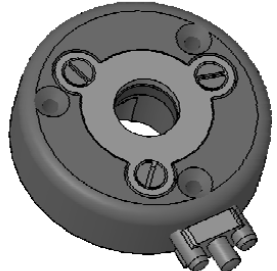
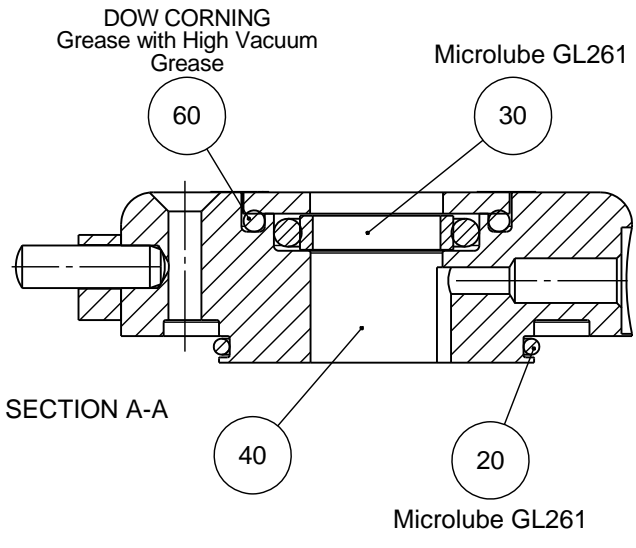
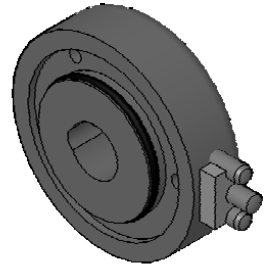
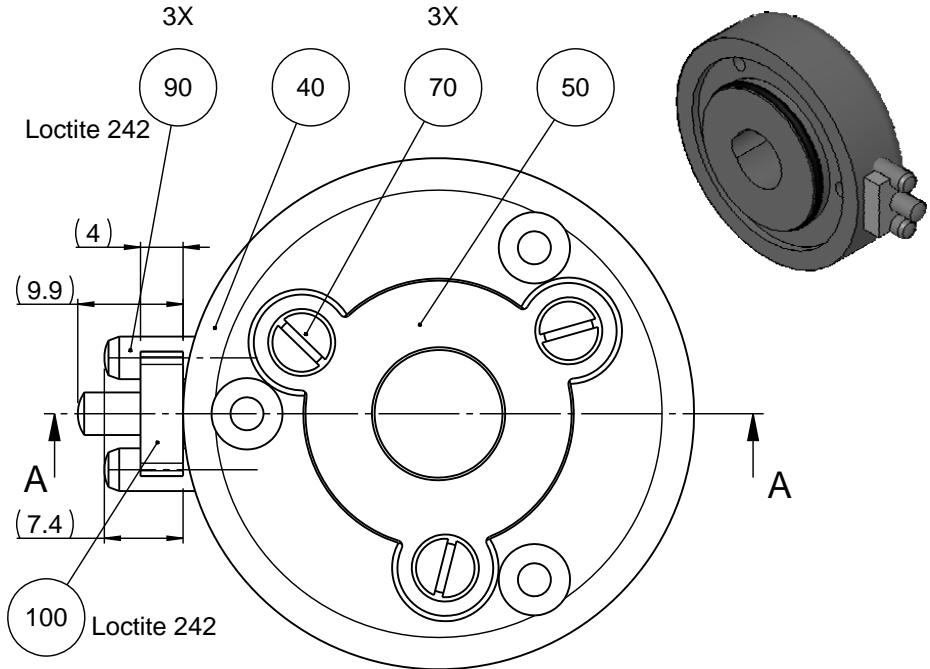

C	2015-09-24	removed pos.80; added pos.90,100	TDR	2015-09-30	ABG
A	2014-09-08		TDR	2015-01-26	ABG
Rev	Crea. date yyyy-mm-dd	Revision description	Draw. Init	Appr. date yyyy-mm-dd	Appr. Init
F	<p>Struers Pederstrupvej 84 DK-2750 Ballerup Copenhagen Denmark Phone: +45 44600 800 Fax: +45 44600 804</p>	Material:	Scale: 2:1	Format: A4	Tolerance: DS/ISO 2768 - - Weight : 0,1797 g
		ID:	Description: 16360065 Stop cover, assembled		

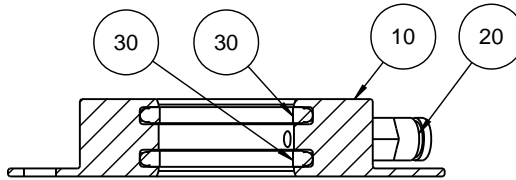
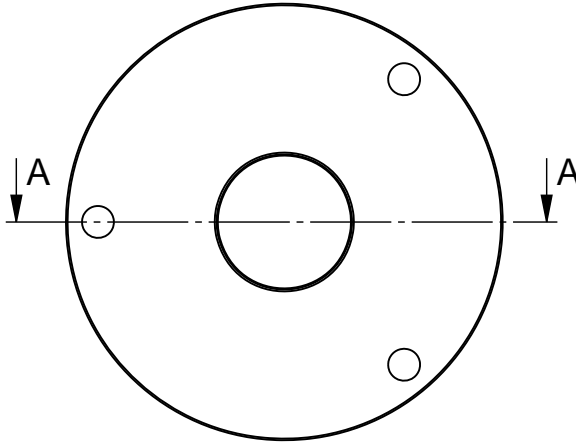

SECTION A-A

30

Grease o-ring and seal with Microlube GL 261

for easy assembly - Do not use grease with solid additives!

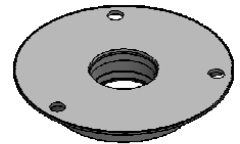

A

A 2015-02-06

Rev

Crea. date
yyyy-mm-dd

Revision description

TDR

2015-02-09

EER

Draw. Init

Appr. date
yyyy-mm-dd

Appr. Init



Pederstrupvej 84
DK-2750 Ballerup
Copenhagen
Denmark
Phone: +45 44600 800
Fax: +45 44600 804



Material:

Scale:

1:1

Format:

A4

Tolerance: DS/ISO 2768 - -

Weight : 80.9 g

ID:

Description:

16360074 Top yoke, assembled

Rev:

A

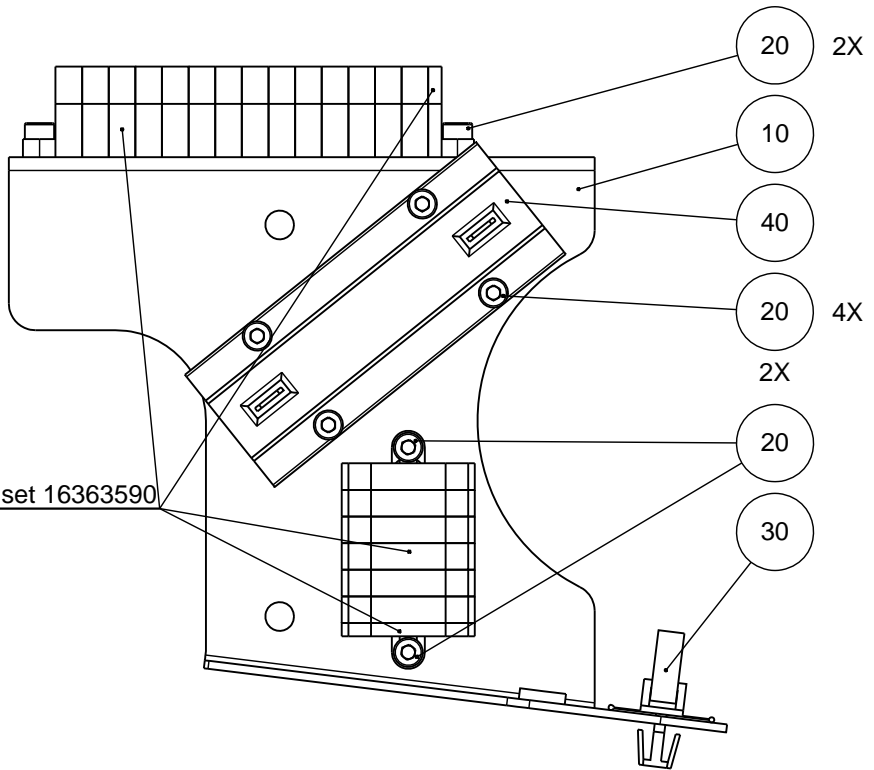
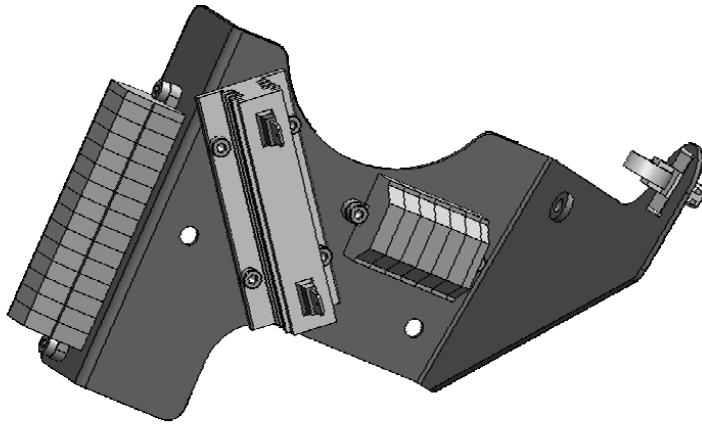

See wire set 16363590

A

B

C



D

E

F

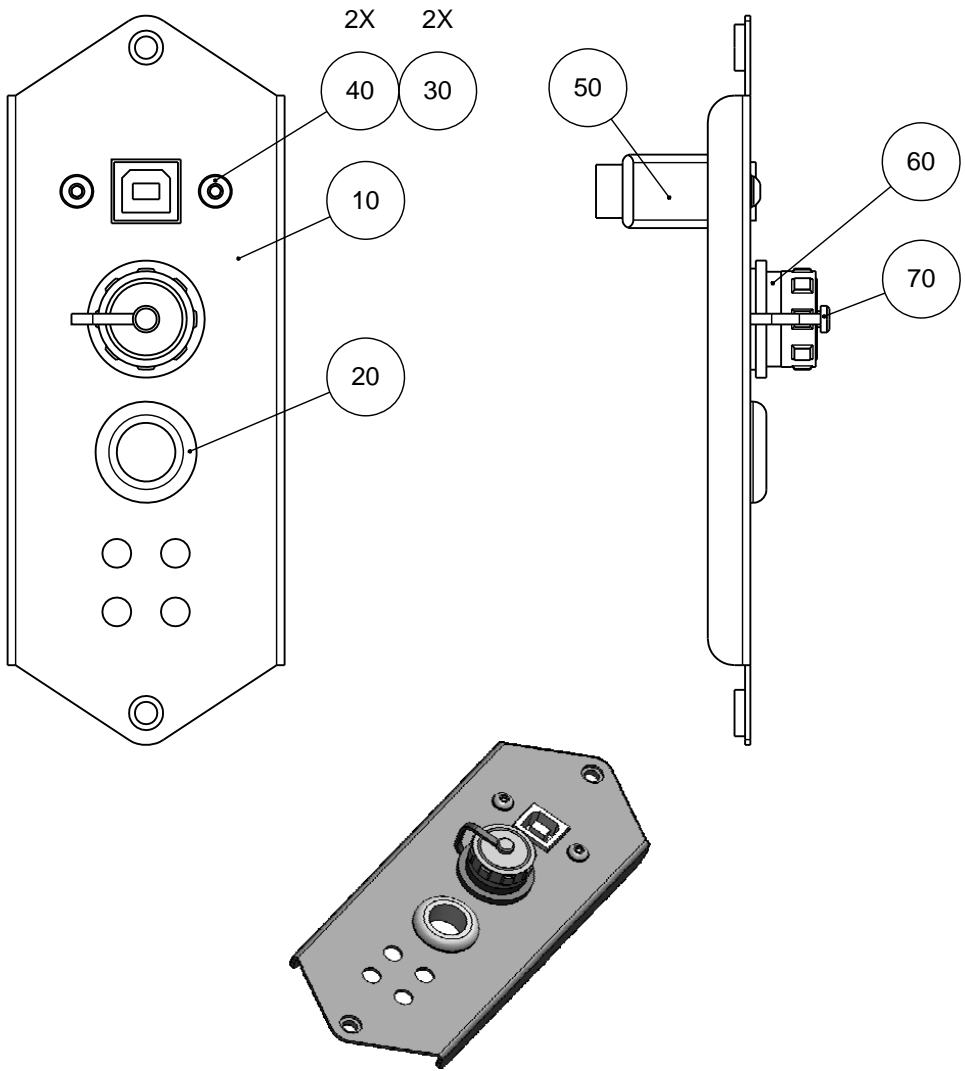
A					
A	2014-08-20		TDR	2015-01-27	ABG
Rev	Crea. date yyyy-mm-dd	Revision description	Draw. Init	Appr. date yyyy-mm-dd	Appr. Init
<p>Pederstrupvej 84 DK-2750 Ballerup Copenhagen Denmark Phone: +45 44600 800 Fax: +45 44600 804</p>		Material:	Scale: 1:1	Format: A4	Tolerance: DS/ISO 2768 - mK Weight : 369.9 g
ID:		Description: 16360080 Hw plate, assembled			Rev: A



A					
A	2015-04-03		TDR	2015-04-07	ABG
Rev	Crea. date yyyy-mm-dd	Revision description	Draw. Init	Appr. date yyyy-mm-dd	Appr. Init
F	 Pederstrupvej 84 DK-2750 Ballerup Copenhagen Denmark Phone : +45 44600 800 Fax : +45 44600 804	 Material:	Scale: 1:1	Format: A4	Tolerance: DS/ISO 2768 - - Weight : 79.6 g
		ID: Description: 16360083 Panel,assembled			

A

B

C

D

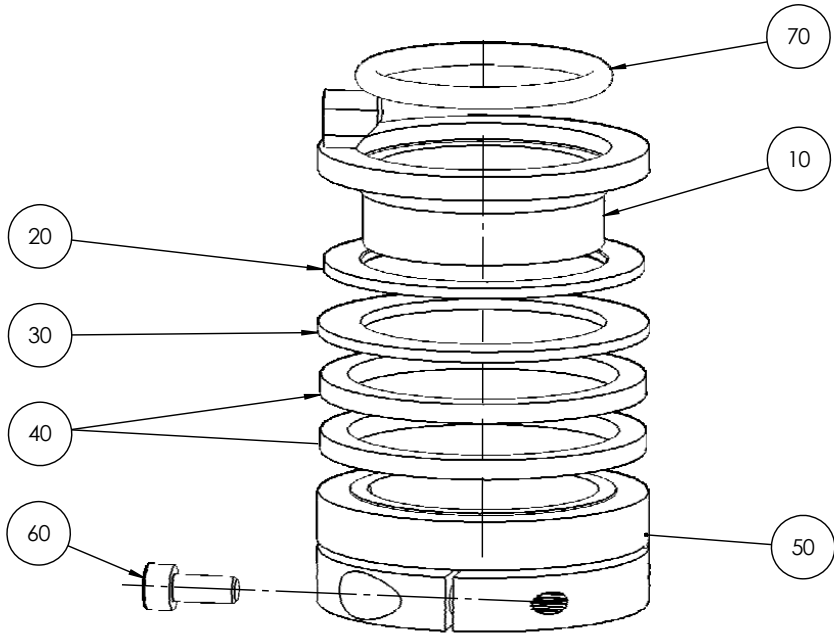

E

F



(10) (60) 785 Parting lubricant

(20) (30) (40) Smøres med olie

G	09-01-08	No changes. PDM failure.		BRY		
F	23-05-07	725 Nikkel Anti Seize Compound->785 Parting lubricant		SPE	23-05-07	JTV
A	09-01-08			BRY		
Rev	Crea. date dd-mm-yy	Revision description		Draw. Init	Appr. date dd-mm-yy	Appr. Init
F	 Pederstrupvej 84 DK-2750 Ballerup Copenhagen Denmark Phone: +45 44600 800 Fax: +45 44600 804	 Material:	Scale: 1:1	Format: A4	Tolerance: DS/ISO 2768 - mK	
					Surface treat.: None	
ID:		Description:				Rev:
		15590013 Friktionskobling				G

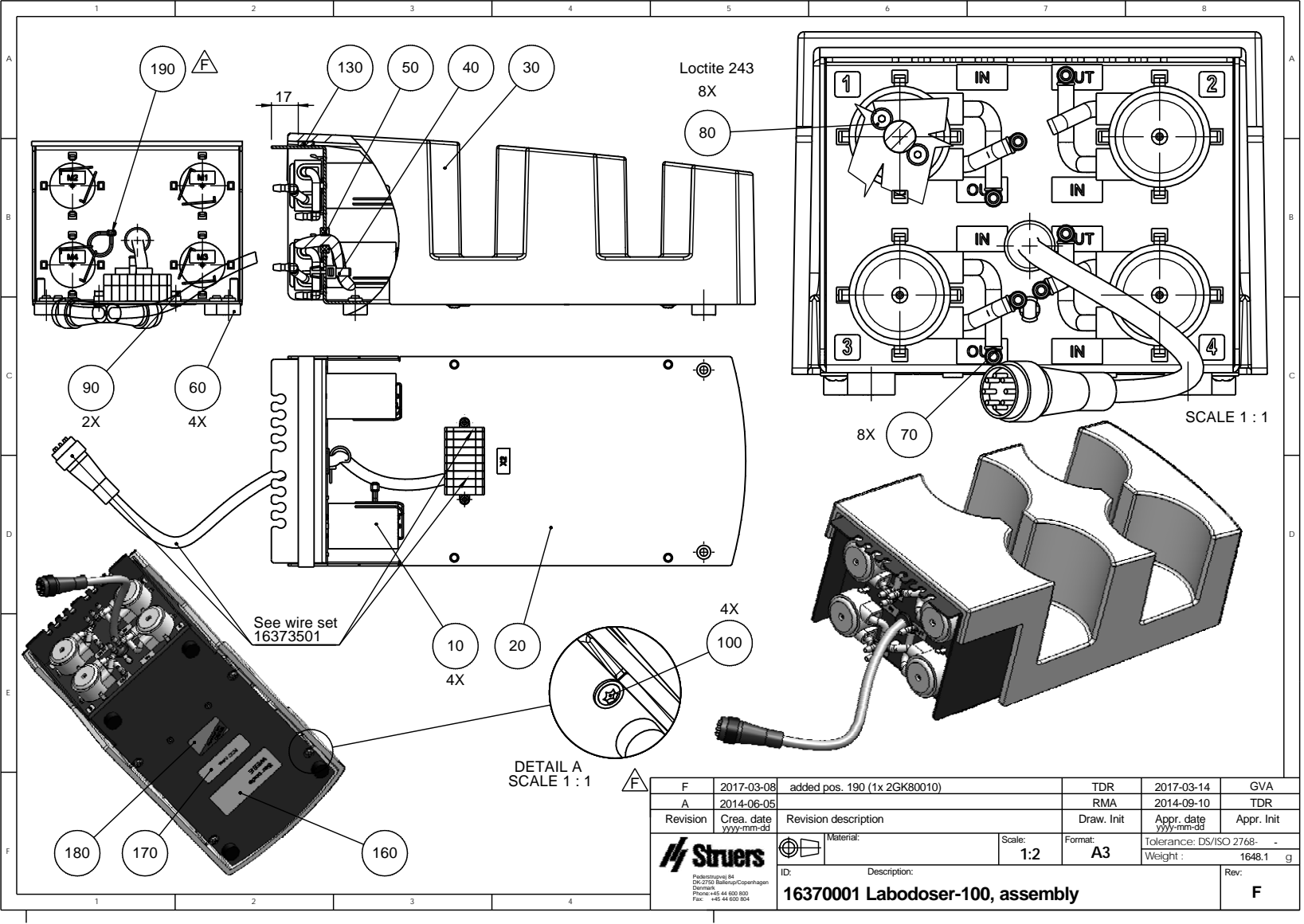

See wire set 16373501

DETAIL A
SCALE 1 : 1

SCALE 1 : 1

F	2017-03-08	added pos. 190 (1x 2GK80010)	TDR	2017-03-14	GVA
A	2014-06-05		RMA	2014-09-10	TDR
Revision	Crea. date yyyy-mm-dd	Revision description	Draw. Init	Appr. date yyyy-mm-dd	Appr. Init
		Material:	Scale: 1:2	Format: A3	Tolerance: DS/ISO 2768: - Weight: 1648.1 g
ID:	Description: 16370001 Labodoser-100, assembly				Rev: F

LABODOSER-100

LABOFORCE-100

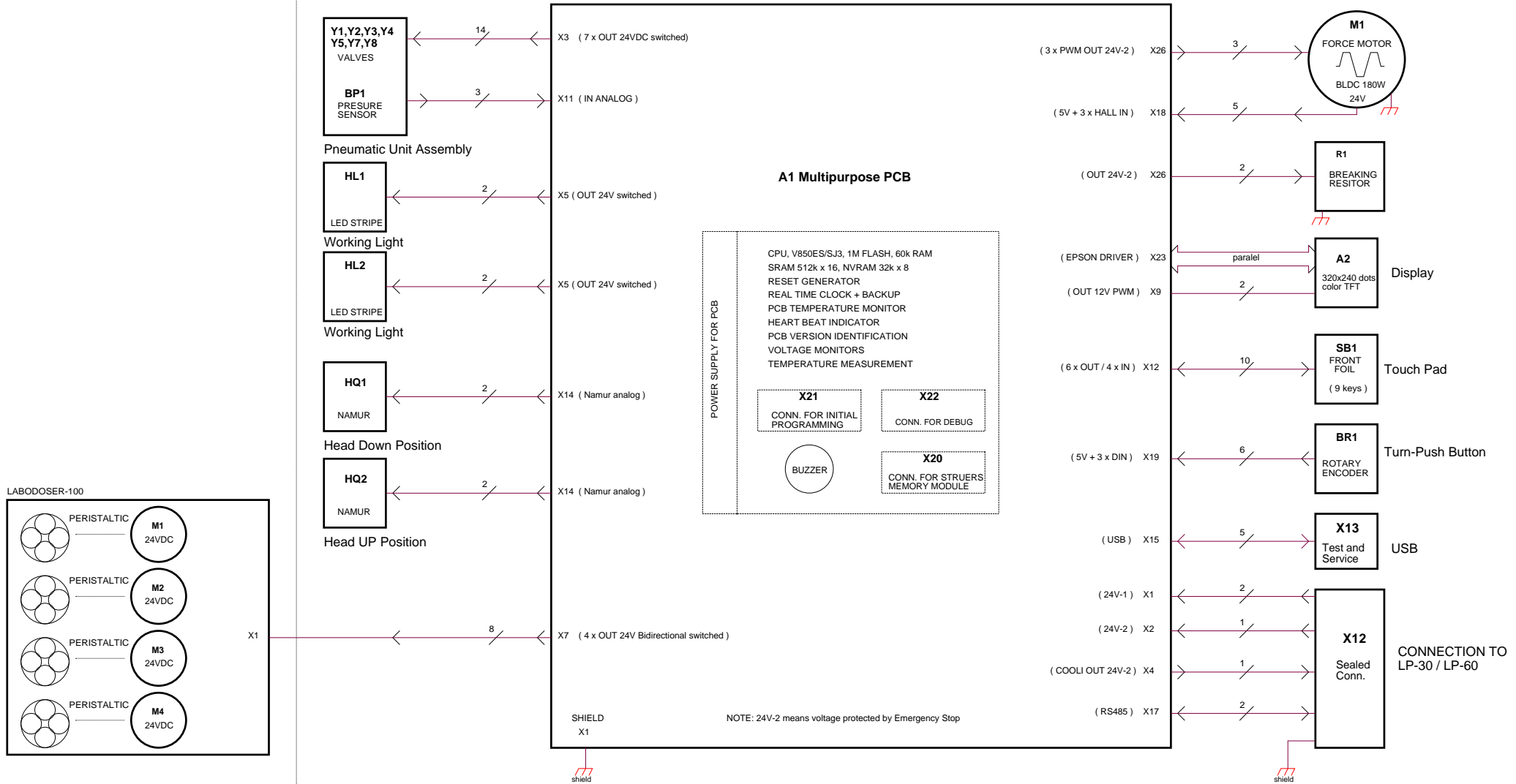

THIS DOCUMENT CONTAINS CONFIDENTIAL AND PROPRIETARY INFORMATION THAT IS THE SOLE PROPERTY OF STRUERS AIS (STRUERS) AND NO OWNERSHIP OR LICENSE RIGHT ARE GARANTED BY DELIVERY OF THIS DOCUMENT TO THE RECEIPT. THIS DOCUMENT AND ALL INFORMATION DISCLOSED HEREIN (A) SHALL NOT BE USED TO MANUFACTURE, CONSTRUCT OR FABRICATE THE GOODS DISCLOSED HEREIN OR ANY DERIVATIVE WORKS OF THE SAME; (B) SHALL NOT BE EXPLOITED OR SOLD BY ANY MEANS; (C) SHALL NOT BE COPIED OR OTHERWISE REPRODUCED IN WHOLE OR IN PART; (D) SHALL NOT BE REVEALED OR DISCLOSED TO ANYONE EXCEPT THOSE PERSONS EMPLOYED OR ENGAGED BY THE RECEIPT AND HAVING A LEGITIMATE NEED TO KNOW; THE INFORMATION CONTAINED IN THIS DOCUMENT, OR IN ANY MANNER MADE PUBLIC WITHOUT THE EXPRESS WRITTEN PERMISSION OF STRUERS; (E) SHALL BE HELD BY RECEIPT OF THIS DOCUMENT IN STRICT CONFIDENCE AS A FIDUCIARY; AND (F) SHALL BE PROTECTED AND KEPT SEPARATE FROM THE DOCUMENTS AND MATERIALS OF THE RECEIPT OF THIS DOCUMENT. THIS DOCUMENT AND ALL INFORMATION CONTAINED HEREIN SHALL REMAIN PROPERTY OF STRUERS AND SHALL BE RETURNED UPON DEMAND ALL PROPRIETARY INFORMATION IS PROVIDED AS IS WITHOUT WARRANTY OF ANY KIND, WHETHER EXPRESS OR IMPLIED, INCLUDING WITHOUT LIMITATION ANY WARRANTIES REGARDING THE TIMELINESS, ACCURACY OR COMPLETENESS OF THE PROPRIETARY INFORMATION.

REV NOTES		Struers AIS Pacemstrøvej 84 DK-2750 Ballerup Denmark Telephone: +45 44 600 800	
Rev. B (OHO 2016-02-05) 24VDC Switched updated to 24V-2		LaboForce-100, LaboDoser-100, Block Diagram	
RevC (MPT 2016-11-14): SHIELD to X12 added		Size A2 CAGE Code DWG NO 16363050 Rev C	
Monday, November 14, 2016		Scale MPT / OHO Sheet 1 of 1	

Pneumatic Unit Assembly

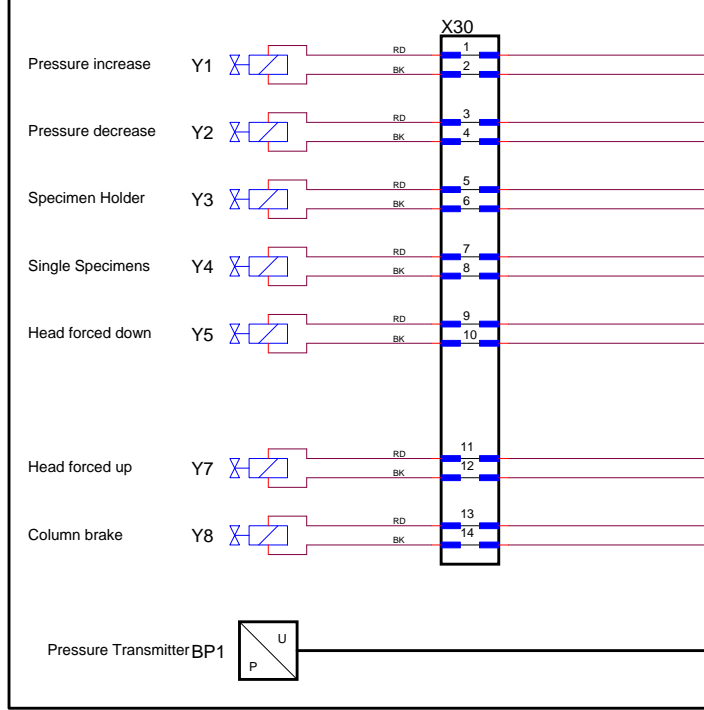

A1 Multipurpose PCB

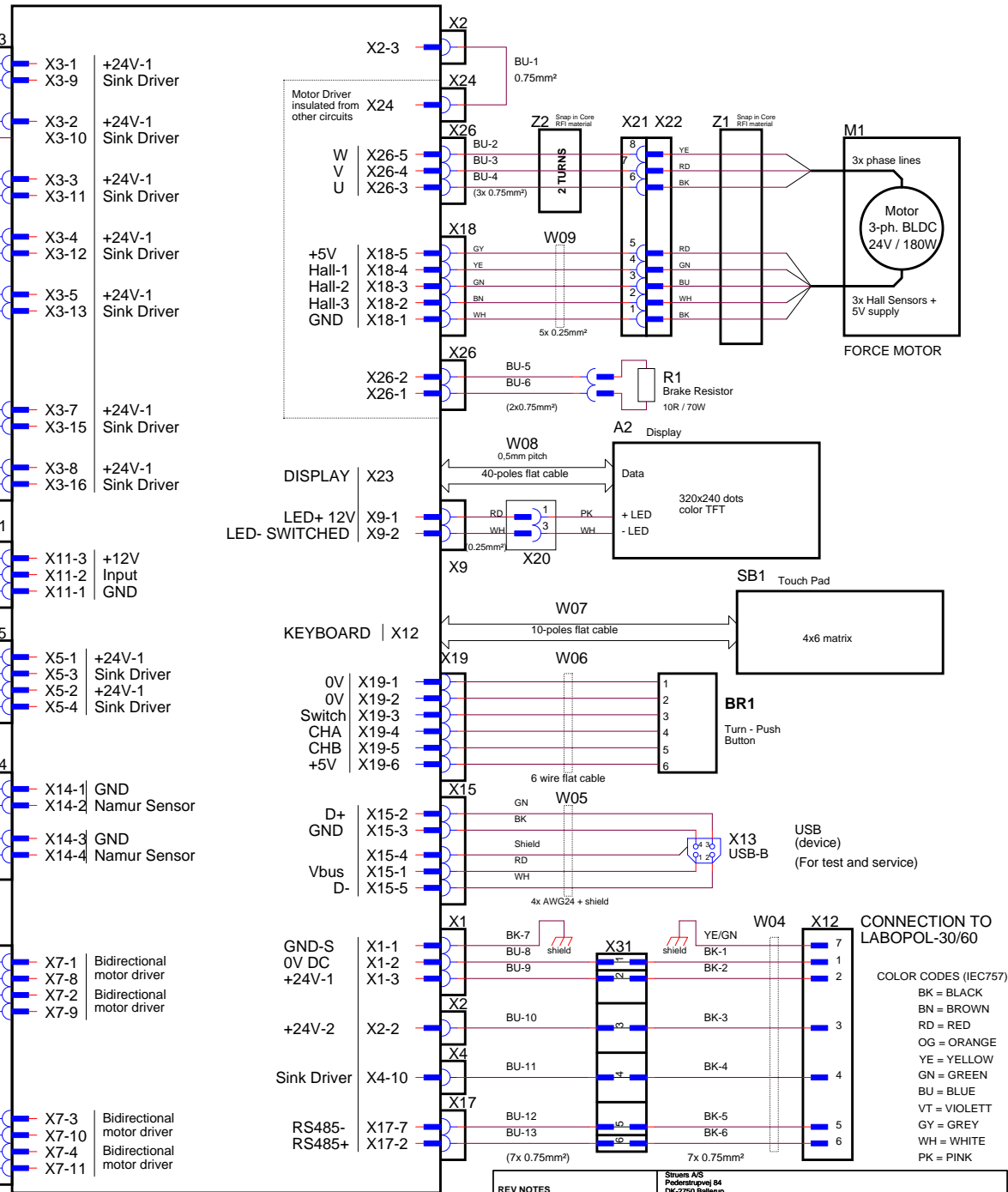

LaboForce-100

LaboDoser-100

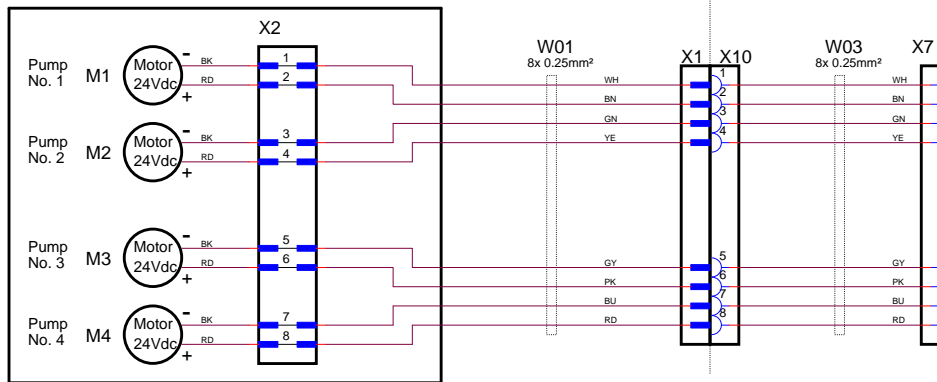

CONNECTION TO LABOPOL-30/60

1	YE/GN	7
2	BK-1	2
3	BK-3	3
4	BK-4	4
5	BK-5	5
6	BK-6	6

COLOR CODES (IEC757):
 BK = BLACK
 BN = BROWN
 RD = RED
 OG = ORANGE
 YE = YELLOW
 GN = GREEN
 BU = BLUE
 VT = VIOLETT
 GY = GREY
 WH = WHITE
 PK = PINK

THIS DOCUMENT CONTAINS CONFIDENTIAL AND PROPRIETARY INFORMATION THAT IS THE SOLE PROPERTY OF STRUERS AIS (STRUERS) AND NO OWNERSHIP OR LICENSE RIGHT ARE GUARANTEED BY DELIVERY OF THIS DOCUMENT TO THE RECIPIENT. THIS DOCUMENT AND ALL INFORMATION DISCLOSED HEREIN (A) SHALL NOT BE USED TO MANUFACTURE, CONSTRUCT OR FABRICATE THE GOODS DISCLOSED HEREIN OR ANY DERIVATIVE WORKS OF THE SAME, (B) SHALL NOT BE EXPLOITED OR SOLD BY ANY MEANS, (C) SHALL NOT BE COPIED OR OTHERWISE REPRODUCED IN WHOLE OR IN PART, (D) SHALL NOT BE REVEALED OR DISCLOSED TO ANYONE EXCEPT THOSE PERSONS EMPLOYED OR ENGAGED BY THE RECIPIENT AND HAVING A LEGITIMATE NEED TO KNOW THE INFORMATION CONTAINED IN THIS DOCUMENT, OR IN ANY MANNER MADE PUBLIC WITHOUT THE EXPRESS WRITTEN PERMISSION OF STRUERS, (E) SHALL BE HELD BY RECIPIENT OF THIS DOCUMENT IN STRICT CONFIDENCE AS A FIDUCIARY, AND (F) SHALL BE PROTECTED AND KEPT SEPARATE FROM THE DOCUMENTS AND MATERIALS OF THE RECIPIENT OF THIS DOCUMENT. THIS DOCUMENT AND ALL INFORMATION CONTAINED HEREIN SHALL REMAIN PROPERTY OF STRUERS AND SHALL BE RETURNED UPON DEMAND ALL PROPRIETARY INFORMATION IS PROVIDED, AS IS WITHOUT WARRANTY OF ANY KIND, WHETHER EXPRESS OR IMPLIED, INCLUDING WITHOUT LIMITATION ANY WARRANTIES REGARDING THE TIMELINESS, ACCURACY OR COMPLETENESS OF THE PROPRIETARY INFORMATION.

REV NOTES		Struers AIS Friederstrævej 64 DK-2750 Ballerup Denmark Telephone: +45 44 600 800	
RevB.: BK-1 and X1 shield added		Size	A2
RevC (MPT 2016-11-14): BK-1 wire label fixed to BK-7; YE/GN wire created		CAGE Code	
RevD (MPT 2017-04-06): Z1 and Z2 added		DWG NO	16363100
Thursday, April 06, 2017		Scale	MPT / OHO
		Sheet	1 of 1

LaboForce-100, LaboDoser-100, Circuit Diagram

COLOR CODE:
 BK = black
 BN = brown
 RD = red
 OG = orange
 YE = yellow
 GN = green
 BU = blue
 VT = violet
 GY = grey
 WH = white
 PK = pink
 BE = beige
 RO = rose
 GNYE = yellow-green

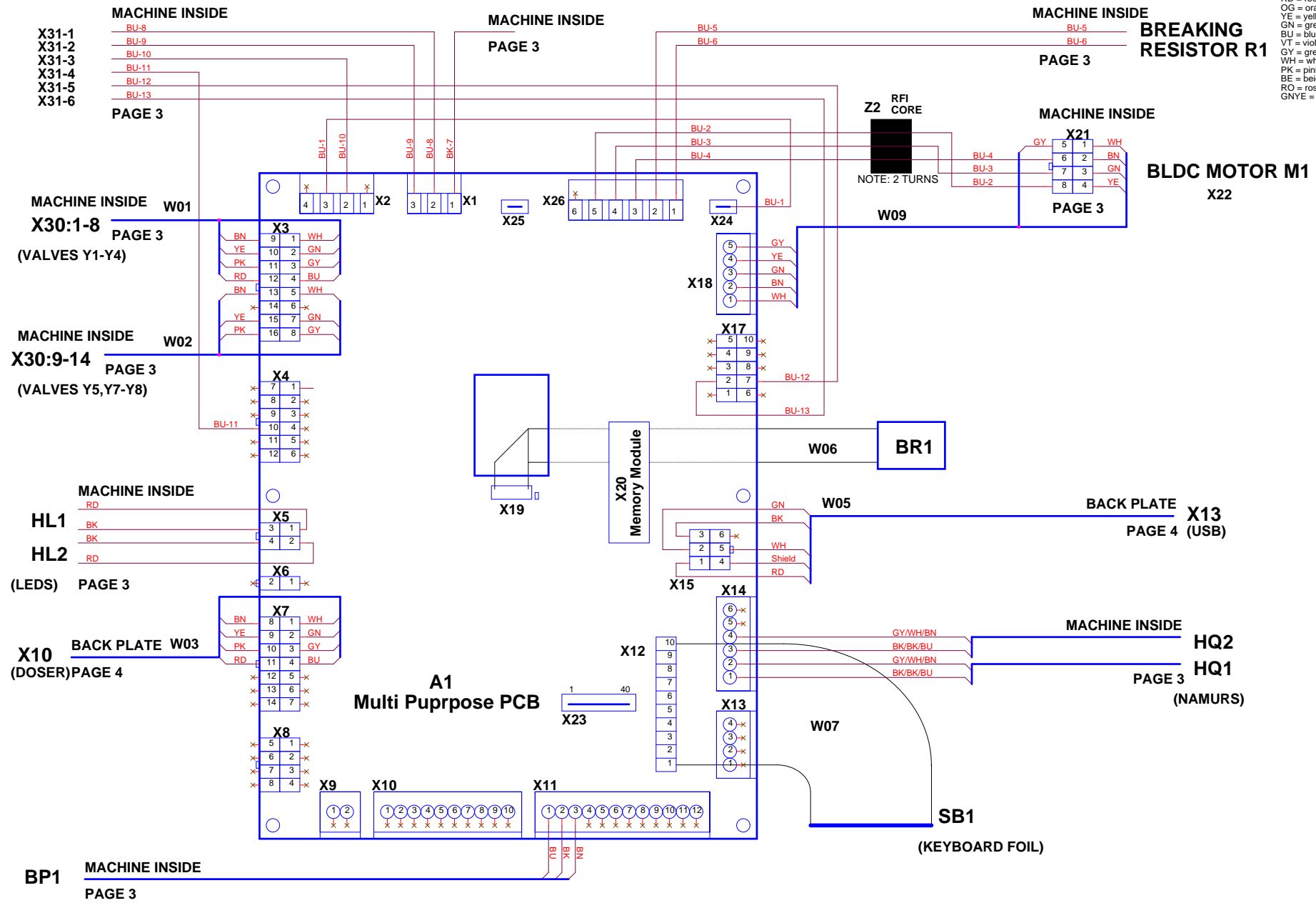

REV NOTES RevB (MPT 2016-11-14): BK-1 wire label fixed to BK-7 RevC (MPT 2017-04-06): Z2 added	STRUER A/S Pødenstrøupvej 84 DK-2750 Ballerup Denmark +45 44 600 800		
	LaboForce-100 Wiring diagram, MULTI PCB, MAIN		
Size A2	CAGE Code	DWG NO 16363450	Rev C
Thursday, April 06, 2017	Scale	MPT / OHO	Sheet 1 of 4

COLOR CODE:
 BK = black
 BN = brown
 RD = red
 OG = orange
 YE = yellow
 GN = green
 BU = blue
 VT = violet
 GY = grey
 WH = white
 PK = pink
 BE = beige
 RO = rose
 GNVE = yellow-green

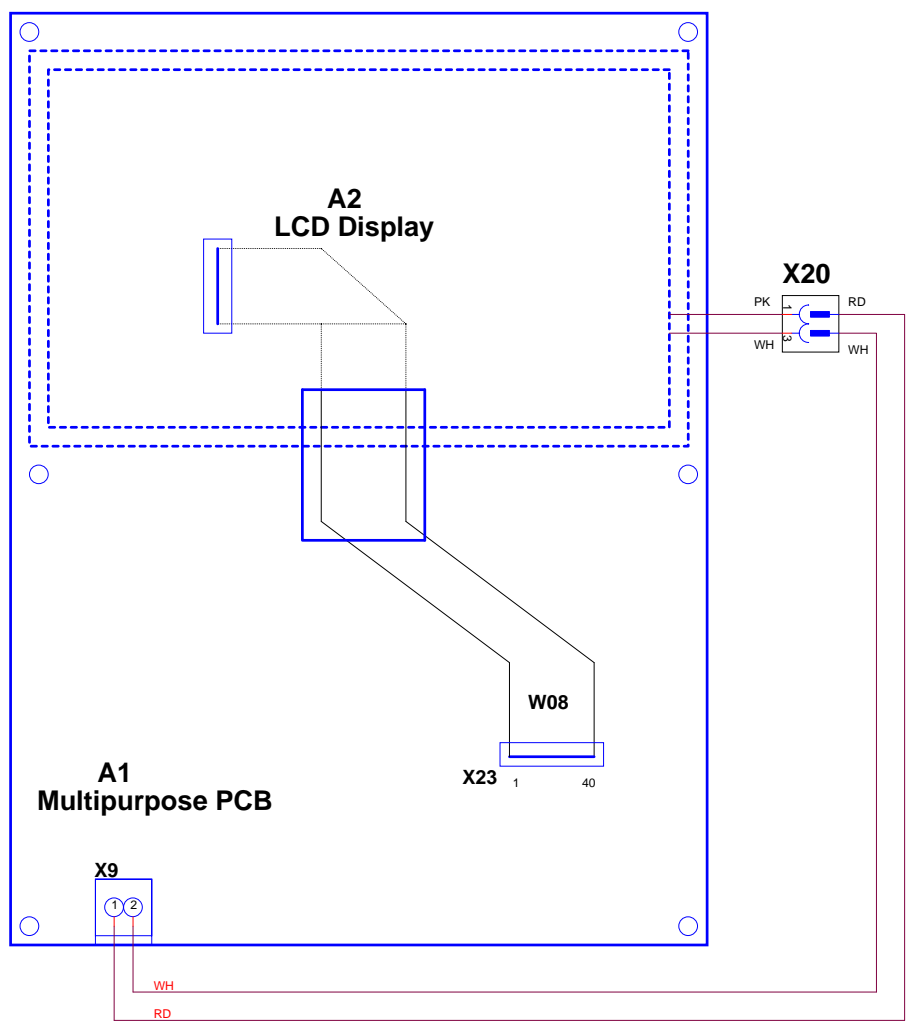

REV NOTES		STRUER'S A/S Pederstrupvej 64 DK-2750 Ballerup Denmark +45 44 600 800	
RevB (MPT 2016-11-14): see other pages		LaboForce-100 Wiring diagram, MULTI PCB, LCD	
RevC (MPT 2017-04-06): see other pages			
Size	CAGE Code	DWG NO	Rev
A2		16363450	C
Thursday, April 06, 2017		Scale	MPT / OHO
		Sheet	2 of 4

COLOR CODE:
 BK = black
 BN = brown
 RD = red
 OG = orange
 YE = yellow
 GN = green
 BU = blue
 VT = violet
 GY = grey
 WH = white
 PK = pink
 BE = beige
 RO = rose
 GNVE = yellow-green

BACK PLATE W04
 PAGE 4

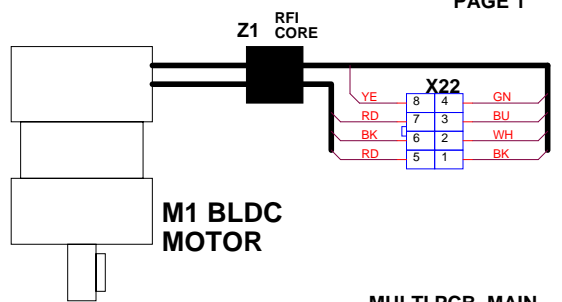
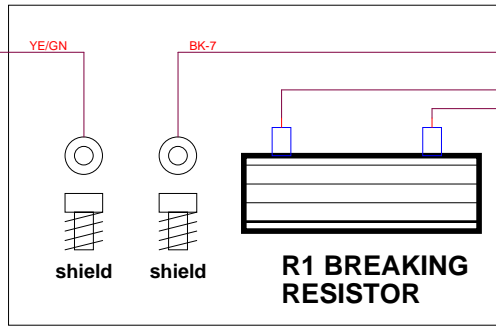

MULTI PCB, MAIN
 A1:X1:1
 A1:X26:1-2
 PAGE 1

HQ2
 Head Up Position

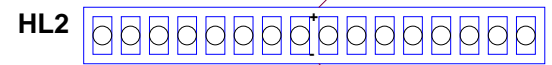
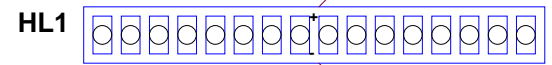

MULTI PCB, MAIN
 PAGE 1
 MULTI PCB, MAIN
 A1:X14
 A1:X5
 PAGE 1

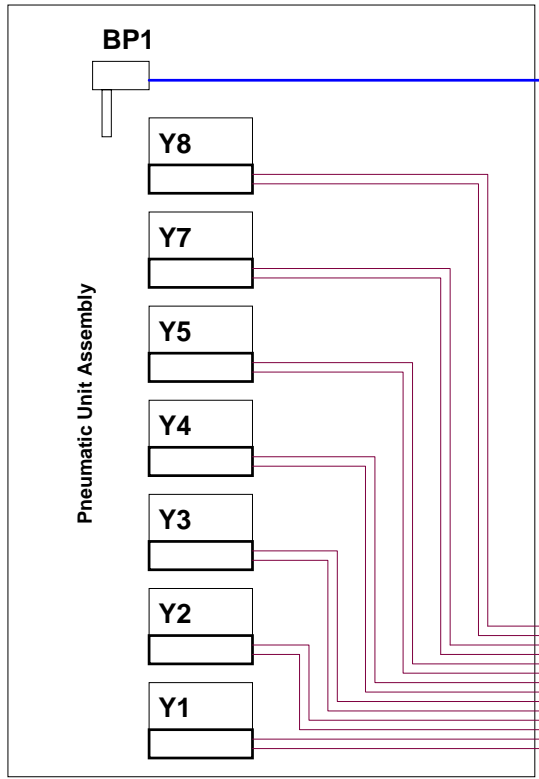

BACK PLATE W04
 PAGE 4

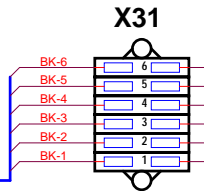

MULTI PCB, MAIN
 PAGE 1
 MULTI PCB, MAIN
 A1:X11
 A1:X17:2,7
 A1:X4:10
 A1:X2:2
 A1:X1:2-3
 PAGE 1

W02 MULTI PCB, MAIN
 PAGE 1
 A1:X3

W01 MULTI PCB, MAIN
 PAGE 1
 A1:X3

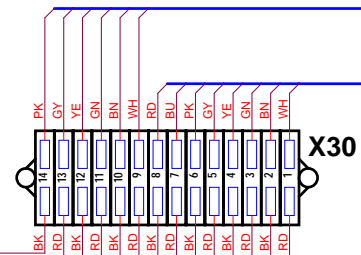

MULTI PCB, MAIN
 PAGE 1
 A1:X14

HQ1
 Head Down Position

REV NOTES		STRUERS A/S Fødemønstvej 64 DK-2750 Ballerup Denmark +45 44 600 800	
RevB (MPT 2016-11-14): BK-1 wire label fixed to BK-7; YE/GN wire created		LaboForce-100 Wiring diagram, INSIDE MACHINE	
RevC (MPT 2017-04-06): Z1 added		Size A2	Rev C
Thursday, April 06, 2017		Scale	MPT / OHO
		DWG NO 16363450	Sheet 3 of 4

COLOR CODE:
 BK = black
 BN = brown
 RD = red
 OG = orange
 YE = yellow
 GN = green
 BU = blue
 VT = violet
 GY = grey
 WH = white
 PK = pink
 BE = beige
 RO = rose
 GNYE = yellow-green

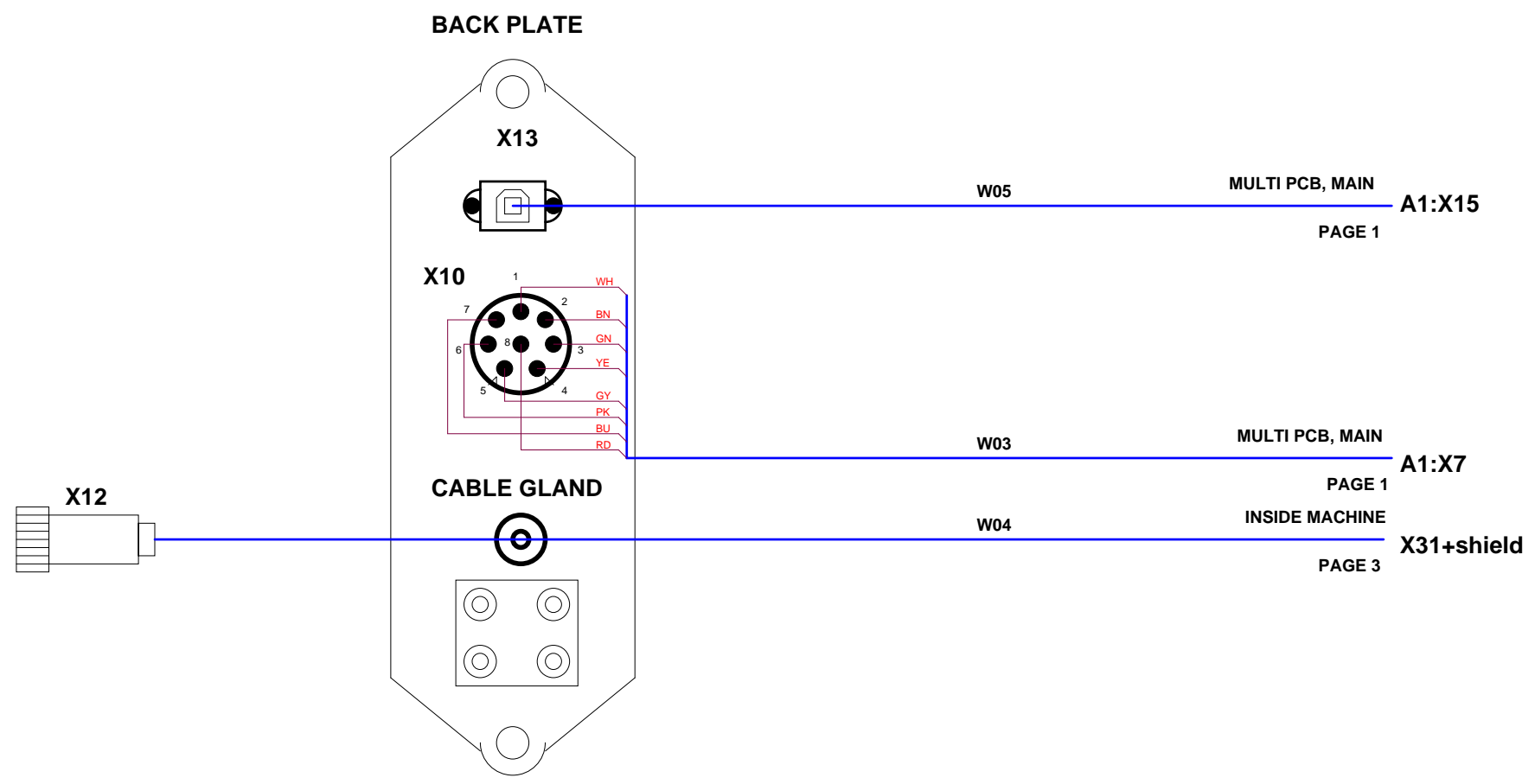

REV NOTES		STRUERS A/S Pederstrupvej 64 DK-2750 Ballerup Denmark +45 44 600 800	
RevB (MPT 2016-11-14): shield note added		LaboForce-100 Wiring diagram, BACK PLATE	
RevC (MPT 2017-04-06): see other pages			
Size	CAGE Code	DWG NO	Rev
A2		16363450	C
Thursday, April 06, 2017	Scale	MPT / OHO	Sheet 4 of 4

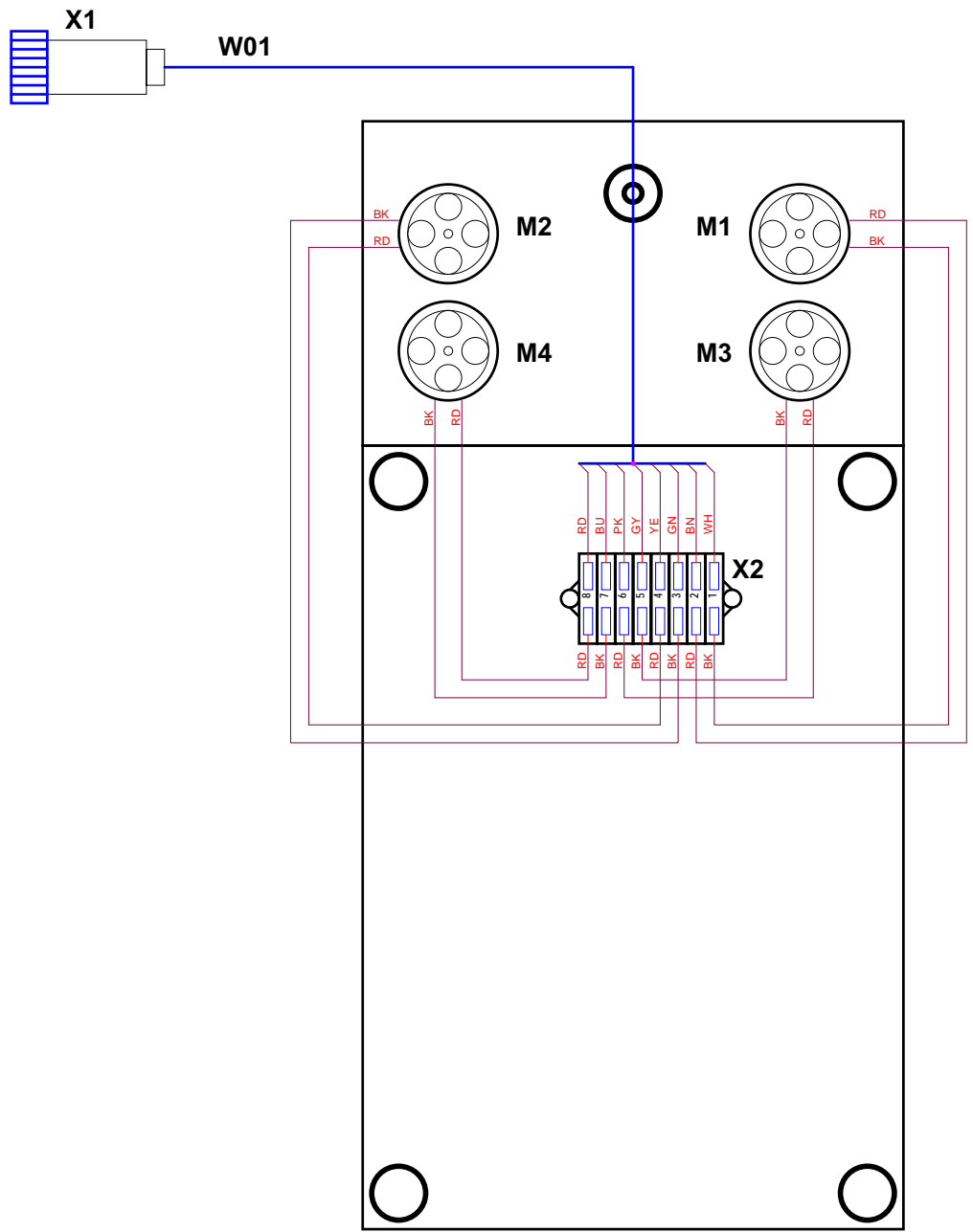

COLOR CODE:
 BK = black
 BN = brown
 RD = red
 OG = orange
 YE = yellow
 GN = green
 BU = blue
 VT = violet
 GY = grey
 WH = white
 PK = pink
 BE = beige
 RO = rose
 GNYE = yellow-green

REV NOTES	STRUERS A/S Pederstrupvej 84 DK-2750 Ballerup Denmark +45 44 600 800			
	LaboDoser-100, Wiring diagram			
Size	CAGE Code	DWG NO	Rev	
A2		16373450	A	
Thursday, March 26, 2015	Scale	TOS/TOS	Sheet	1 of 1

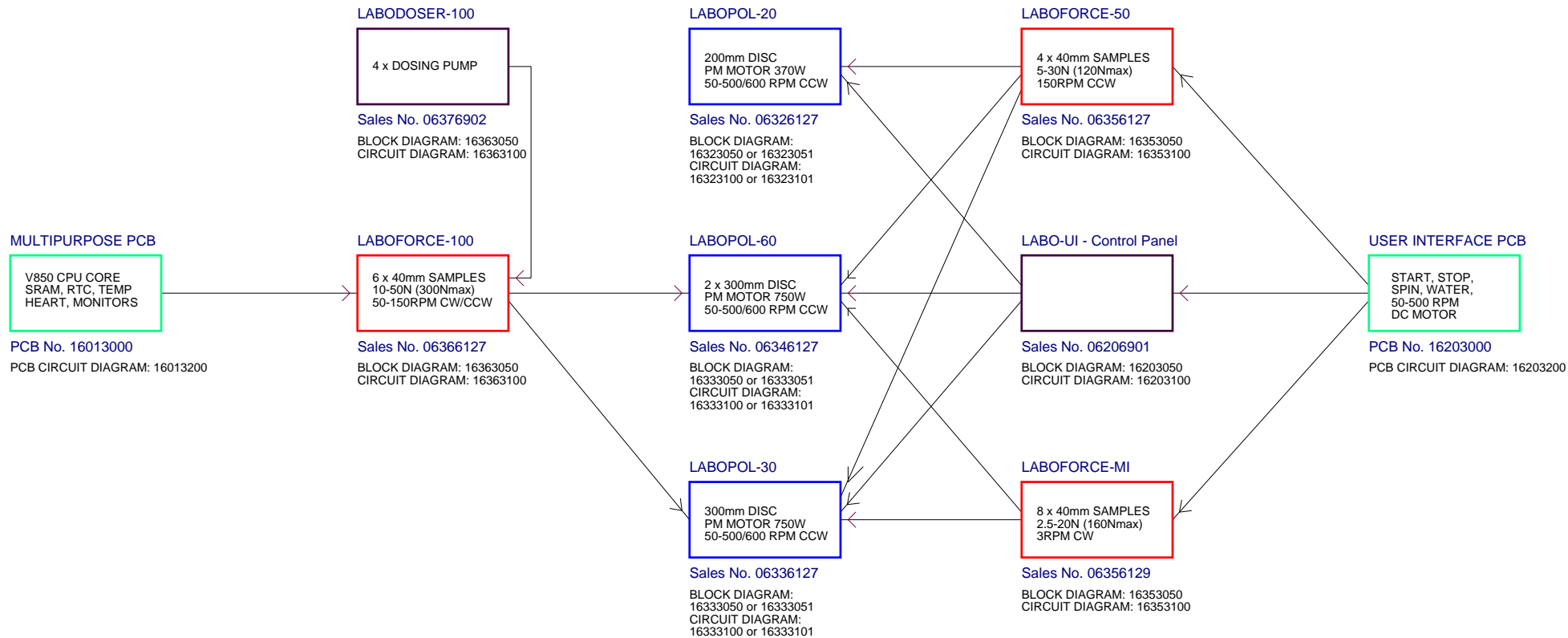

THIS DOCUMENT CONTAINS CONFIDENTIAL AND PROPRIETARY INFORMATION THAT IS THE SOLE PROPERTY OF STRUERS A/S (STRUERS) AND NO OWNERSHIP OR LICENSE RIGHT ARE GUARANTEED BY DELIVERY OF THIS DOCUMENT TO THE RECIPIENT. THIS DOCUMENT AND ALL INFORMATION DISCLOSED HEREIN (A) SHALL NOT BE USED TO MANUFACTURE, CONSTRUCT OR FABRICATE THE GOODS DISCLOSED HEREIN OR ANY DERIVATIVE WORKS OF THE SAME; (B) SHALL NOT BE EXPLOITED OR SOLD BY ANY MEANS; (C) SHALL NOT BE COPIED OR OTHERWISE REPRODUCED IN WHOLE OR IN PART; (D) SHALL NOT BE REVEALED OR DISCLOSED TO ANYONE EXCEPT THOSE PERSONS EMPLOYED OR ENGAGED BY THE RECIPIENT AND HAVING A LEGITIMATE NEED TO KNOW THE INFORMATION CONTAINED IN THIS DOCUMENT; OR IN ANY MANNER MADE PUBLIC WITHOUT THE EXPRESS WRITTEN PERMISSION OF STRUERS; (E) SHALL BE HELD BY RECIPIENT OF THIS DOCUMENT IN STRICT CONFIDENCE AS A FIDUCIARY; AND (F) SHALL BE PROTECTED AND KEPT SEPARATE FROM THE DOCUMENTS AND MATERIALS OF THE RECIPIENT OF THIS DOCUMENT. THIS DOCUMENT AND ALL INFORMATION CONTAINED HEREIN SHALL REMAIN PROPERTY OF STRUERS AND SHALL BE RETURNED UPON DEMAND. ALL PROPRIETARY INFORMATION IS PROVIDED "AS IS" WITHOUT WARRANTY OF ANY KIND, WHETHER EXPRESS OR IMPLIED, INCLUDING WITHOUT LIMITATION ANY WARRANTIES REGARDING THE TIMELINESS, ACCURACY OR COMPLETENESS OF THE PROPRIETARY INFORMATION.

REV NOTES		Struers A/S Pacemstrøvej 84 DK-2750 Ballerup Denmark Telephone: +45 44 600 800	
Rev. B (MPT 2017-06-14) Block and circuit diagram numbers added with respect to Compliance changes update		LaboSystem-100 TOTAL OVERVIEW, Block Diagram	
Size A2	CAGE Code	DWG NO 16203051	Rev B
Scale	TOS / MPT	Sheet 1	of 1
Wednesday, June 14, 2017			



Pederstrupvej 84
DK-2750 Ballerup
Denmark